

PARTS AND SERVICE MANUAL NORTH AMERICA

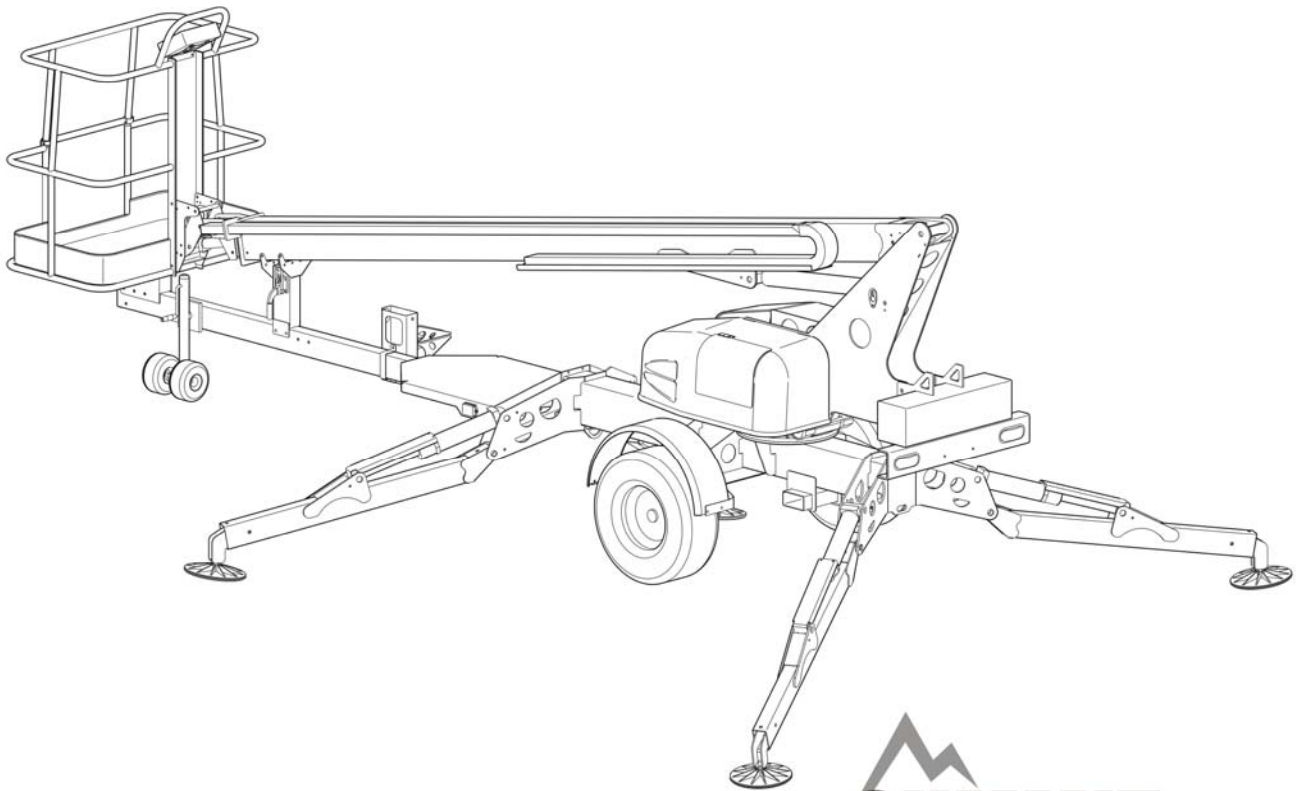

3632T / HTT 13



AERIAL WORK PLATFORM

This equipment is designed and manufactured in compliance with the duties, responsibilities and standards set forth for manufacturers in the ANSI, CSA, AS and / or CE standards in effect at the time of manufacture.

This equipment meets or exceeds applicable ANSI, CSA, AS and / or CE codes and standards when operated in accordance with manufacturer's recommendations.

It is the responsibility of the user to follow all regional codes and regulations that govern the safe operation of this equipment.

Obtain, read and obey all safety precautions before performing maintenance or repairs or attempting to operate this equipment. This includes all manufacturer recommendations as well as those directives set forth by government and local authorities.

To ensure proper and safe use of this equipment, it is strongly recommended that only trained and authorized personnel attempt to operate and maintain the aerial work platform.

This manual shall be considered a permanent and necessary component of the aerial work platform and shall be kept with the machine at all times.

Owners and Lessors should complete a full inspection of all components and perform a test of all functions, including brake functions, before commissioning or reselling the aerial work platform. Repair or replace all damaged or malfunctioning components.

Haulotte Group is dedicated to the continuous improvement of this and all Haulotte Group products. Therefore, equipment information is subject to change without notice. Direct any questions or concerns regarding errors and / or discrepancies in this manual to the Haulotte Group Service Department.

CALIFORNIA

Proposition 65 Warning

Diesel engine exhaust and some of its constituents are known to the State of California to cause cancer, birth defects, and other reproductive harm.

Haulotte 
G R O U P

125 Taylor Parkway
Archbold, Ohio 43502

Phone 1-(888)-440-9240
Fax (419) 445-0367
www.haulotte-usa.com

TABLE OF CONTENTS

1	SAFETY	5
	LEGEND: SAFETY ADVISORIES.....	5
	BEFORE OPERATION.....	6
	DURING OPERATION.....	7
	FALL PROTECTION	9
	MANUAL FORCE.....	9
	WIND LOADING.....	9
	EXPLOSION HAZARD.....	10
	MAINTENANCE	11
2	SPECIFICATIONS	13
	RANGE OF MOTION	13
	SPECIFICATIONS.....	14
	WARRANTY - NEW PRODUCT; HAULOTTE NORTH AMERICA	16
	WARRANTY CLAIMS PROCEDURE.....	17
	DAMAGED EQUIPMENT POLICY.....	18
3	EQUIPMENT MAINTENANCE	19
	BATTERY RECHARGE.....	20
	DAILY SERVICE CHECKS	24
	WEEKLY SERVICE CHECKS.....	27
	MONTHLY SERVICE CHECKS	28
	ANNUAL SERVICE CHECKS	29
	STRUCTURAL INSPECTION	31
	MOTOR DRYING INSTRUCTIONS	31
	ADDITIONAL SERVICE INFORMATION.....	32
	TROUBLESHOOTING	33
	ERROR CODE DEFINITIONS – CONTROLS	34
	ERROR CODE DEFINITIONS – MOTOR CONTROLLER	46
4	CYLINDER REPLACEMENT	49
	LIFT CYLINDER REPLACEMENT.....	49
	OUTRIGGER CYLINDER REPLACEMENT.....	51
5	DECAL REPLACEMENT	53
	DECAL REPLACEMENT – DECAL KIT.....	54
	DECAL REPLACEMENT – IDENTIFICATION PLATES & OPTIONAL EQUIPMENT	56
6	REPLACEMENT PARTS	59
7	SCHEMATICS.....	123
8	OPTIONAL EQUIPMENT.....	157
9	MATERIAL SAFETY	173
10	AXLE AND RELATED COMPONENTS	183
	SET UP AND ADJUSTMENT.....	183
	HOW TO USE YOUR BRAKES PROPERLY.....	190
	MAINTENANCE	191
	STORAGE	212
	TROUBLE SHOOTING	215
11	ANSI REPRINT	221
	INSPECTION FORM FOR HAULOTTE GROUP AERIAL WORK PLATFORMS.....	228

LIST OF ILLUSTRATIONS

Figure 2-1. Range of Motion	13
Figure 3-1. Battery Charger Faceplate.....	20
Figure 3-2. Outrigger Position Switches.....	25
Figure 3-3. Hydraulic Reservoir	26
Figure 3-4. Wheel Nut Tightening Sequence	28
Figure 3-5. Slew Ring Position Measurement.....	30
Figure 3-6. Platform Rotation for Slew Ring Measurement.....	Error! Bookmark not defined.
Figure 3-7. Motor Controller.....	47
Figure 4-1. Location of Emergency Lowering Valve Handle	49
Figure 4-2. Lift Cylinder Replacement.....	50
Figure 4-3. Outrigger Cylinder Replacement	51
Figure 4-4. Cylinder Valve Removal	51
Figure 8-1. Load Sense Module.....	166
Figure 8-2. Ground Control Panel Receptacle	166
Figure 8-3. Platform Removal	167
Figure 8-4. Material Lifting Hook Installation.....	167
Figure 8-5. Material Lift “Stowed” Position	168
Figure 8-6. Material Lift “In Use” Position.....	168
Figure 11-1. Minimum Safe Approach Distance	227

LIST OF TABLES

TABLE 1-1. MINIMUM SAFE APPROACH DISTANCES	7
TABLE 1-2. BEAUFORT SCALE OF WIND FORCE	10
TABLE 3-2. TROUBLE SHOOTING.....	33
TABLE 3-3. ERROR CODE DEFINITIONS.....	34
TABLE 3-4. MOTOR CONTROLLER ERROR CODE DEFINITIONS.....	46
TABLE 11-1. MINIMUM SAFE APPROACH DISTANCES	227

1 SAFETY

Proper training is required for the safe operation of any mechanical device. Failure to follow all instructions and safety precautions in this manual and attached to the aerial work platform will result in death or personal injury.

Prior to Operation:

- Read, understand and obey all instructions and safety precautions in this manual and attached to the aerial work platform.
- Read, understand and obey all applicable government regulations.
- Become familiar with the proper use of all controls.
- Inexperienced users should receive instruction by a qualified operator before attempting to operate or maintain the aerial work platform.

The use of intelligence and common sense is the best practice when following any safety policy.

LEGEND: SAFETY ADVISORIES

The following safety advisories are used throughout this manual to indicate specific hazards when operating or maintaining the aerial work platform. Read, understand and obey all safety advisories to prevent improper service, damage to equipment, personal injury or death.



DANGER

Indicates a hazardous situation which if not avoided, will result in death or serious injury.



WARNING

Indicates a hazardous situation which if not avoided, could result in death or serious injury.



CAUTION

Indicates a hazardous situation which, if not avoided, may result in minor or moderate injury.

NOTICE

Contains information important in the prevention of errors that could damage the machine or its components.

NOTE: Contains additional information important for performing a procedure.

BEFORE OPERATION

Ensure the following general safety precautions are followed before operating the aerial work platform:

ALWAYS inspect the usage area for potential hazards, such as unstable or unlevel surfaces, overhead obstructions and electrically charged wires or conductors. **ALWAYS** watch for moving vehicles in the operating area.

ALWAYS conduct a thorough visual inspection of the aerial work platform before operation. Check for damaged or worn parts, hydraulic leaks, damaged wiring, loose wiring conductors, damaged outriggers, low tire pressure, uneven tire wear or tire damage. Check for any improperly operating components. **NEVER** operate the aerial work platform if any damage is observed or suspected. Repair damaged or malfunctioning equipment before operation.

ALWAYS wear proper clothing. Wear protective equipment as required by government regulations. Keep loose clothing, jewelry, gloves and hair away from moving parts.

ALWAYS wear a Safety Harness and energy-absorbing Lanyard, such as the Safety Harness and Lanyard available through the Haulotte Group.

ALWAYS inspect platform floor and outrigger footpads for mud, grease, debris or other foreign material. **ALWAYS** remove any such material from the aerial work platform before operation.

ALWAYS RED tag any part of the aerial work platform known or suspected to be damaged or malfunctioning. **ALWAYS** remove a malfunctioning, damaged or defective aerial work platform from service. **NEVER** operate an aerial work platform that has any known or suspected defect.

ALWAYS comply with the instructions found in Safety and / or Service Bulletins distributed by the manufacturer / factory. Bulletins may contain critical procedures that supersede the information contained in the manual.

NEVER operate this aerial work platform while under the influence of drugs or alcohol, while taking prescription medications that may leave the operator drowsy or prone to dizziness, or while feeling ill.

NEVER modify, alter or change the aerial work platform in any way that would affect its original design or operation.

NEVER deface, modify or obscure any decals or markings on the aerial work platform.

NEVER operate the aerial work platform in any way for which it is not intended.

DURING OPERATION

Ensure the following general safety precautions are followed while operating the aerial work platform:

ALWAYS position away from power lines to ensure that no part of the aerial work platform can accidentally reach into an unsafe area. This includes full extension of the telescoping boom through 700° rotation.

 **DANGER**

This aerial work platform is **NOT** insulated for use near electrical power lines and **DOES NOT** provide protection from contact with or close proximity to any electrically charged conductor. Operator must maintain safe clearances at all times (10 ft (3.05m) minimum) and must always allow for Platform movement due to gusty winds. Always contact power company before working near power lines. Assume every power line is live. Power lines can be blown by the wind.

Refer to Table 1-1 for minimum safe approach distances between the machine and electrical power lines.

TABLE 1-1. MINIMUM SAFE APPROACH DISTANCES		
Voltage Range (Phase to Phase)	Minimum Safe Approach Distance	
	(Feet)	(Meters)
0 to 300V	Avoid Contact	
Over 300V to 50KV	10	3.05
Over 50KV to 200KV	15	4.60
Over 200KV to 350KV	20	6.10
Over 350KV to 500KV	25	7.62
Over 500KV to 750KV	35	10.67
Over 750KV to 1000KV	45	13.72

ALWAYS keep away from an aerial work platform that is exposed to electrically charged power lines. If the aerial work platform comes in contact with electrically charged power lines, **NEVER** touch or operate the aerial work platform until power lines are shut off.

ALWAYS operate only on a firm and level surface. **NEVER** operate on surfaces that do not support the aerial work platform with its rated load capacity or on surfaces that do not support force exerted by the outriggers during aerial work platform operation. Operate only on surfaces that can support a pressure of 1.8 kg/cm² (25 psi) to ensure safe operation.

ALWAYS keep personnel away from potential pinch and shear points and from potential crush hazards as indicated by decals attached to the aerial work platform.

ALWAYS keep the safety bar lowered (closed) unless personnel are entering or exiting the work platform.

ALWAYS wear proper footgear. **ALWAYS** keep the platform free of debris.

DURING OPERATION (CONTINUED)

ALWAYS keep personnel and obstructions clear of the aerial work platform when repositioning the telescoping boom or cage.

ALWAYS cordon the area surrounding the outriggers to keep personnel, vehicles and moving equipment away from the aerial work platform while in use.

ALWAYS stay clear of overhead obstructions, including wires and cables.

ALWAYS unhitch trailer from tow vehicle before operating outriggers.

NOTICE

Failure to unhitch trailer from tow vehicle prior to outrigger deployment could cause damage to trailer tongue and / or tow vehicle.

ALWAYS disengage aerial work platform travel latches before raising aerial work platform sections and reengage aerial work platform travel latches before towing trailer.

ALWAYS exercise caution when rotating the boom from the ground control station. **ALWAYS** watch for personnel inside the radius of the turntable and boom arm when rotating from the ground or platform controls.

ALWAYS remove personnel from the aerial work platform before attempting to free an elevated platform that has become caught or snagged on an adjacent structure or obstacle.

NEVER operate the aerial work platform from a position on a truck-bed, trailer, floating vessel or scaffolding without written approval from the manufacturer / factory.

NEVER operate the Drive function (if equipped) on surfaces exceeding 4.5°, or with more than one person in the platform

ALWAYS maintain drive enable button during drive operation.

NEVER allow electrode contact with any part of the aerial work platform while welding from the platform. **NEVER** use the aerial work platform as a ground for welding.

NEVER operate without the outriggers fully extended or when the aerial work platform is not level.

NEVER position an elevated platform against another object to steady the platform.

NEVER override or bypass the manufacturer's safety devices.

NEVER attach a safety harness to an adjacent structure, pole, or to nearby equipment while working from the platform (cage).

NEVER raise the outriggers or move the trailer with materials or personnel on board, or while telescoping boom is raised or extended.

NEVER sit, stand or climb on platform (cage) railing. **ALWAYS** keep both feet firmly on the platform (cage) floor.

NEVER attempt to increase the working height with boxes, ladders, stools or any other materials.

NEVER operate this aerial work platform when exposed to high winds, thunderstorms, ice or any weather conditions that would compromise operator safety.

NEVER operate aerial work platform in conditions where wind speeds exceed 28 mph (12.5 m/sec, or 45 km/h). Steady or gusty winds that exceed recommended wind speeds that may affect stability and aerial work platform operation.

DURING OPERATION (CONTINUED)

NEVER allow ropes, electric cords, hoses or other equipment to become entangled with the aerial work platform.

NEVER exceed the load limits set by the manufacturer / factory. Use only the material lifting hook, supplied as an option and manufactured by Haulotte Group when lifting materials. Safely stow all tools and equipment.

NEVER exceed load ratings by transferring loads to the aerial work platform at elevated heights.

NEVER use the platform to lift a load that exceeds the platform dimensions. **NEVER** lift a load in such a way that the center of gravity is higher than the top guardrail of the platform.

NEVER modify the platform (cage) or carry materials that would increase the surface area of the platform. Increasing the area exposed to the wind may affect the aerial work platform stability.

NEVER attach overhanging loads when raising or lowering the platform.

NEVER use the boom or platform to push or pull or to lift any part of the trailer.

NEVER use the boom or platform to place a load against any structure, materials or equipment.

NEVER climb on the telescoping boom. Refer to the "Operation" Section of the Operation Manual for manual operation.

NEVER leave an elevated platform unattended.

NEVER leave the keys in the aerial work platform while unattended or not in use.

FALL PROTECTION

- Occupants must wear a safety belt or harness in accordance with governmental regulations. Attach lanyard to the anchor provided on the work platform (cage).
- **Never** sit, stand, or climb on the platform guard rails. Maintain a firm footing on the platform floor at all times.
- **Never** climb down from the platform when raised. If a power failure should occur, ground personnel should use the manual controls to lower the platform.
- Keep platform floor clear of debris.
- Lower the platform entry mid-rail or close the entry gate before operating.



MANUAL FORCE

- **Never** push off or pull toward any object outside the platform.
- Maximum allowable manual force is 90 lb. (400 N).

WIND LOADING

- **Never** operate the aerial work platform in strong or gusty winds. **Never** increase the surface area of the platform or the load. Increasing the area exposed to the wind will affect the work platform (cage) stability.

WIND LOADING (CONTINUED)

The Beaufort scale of wind force is accepted internationally and is used when communicating weather conditions. It consists of a number 0-17, each representing a certain strength or velocity of wind at 10m (33ft) above ground level in the open. Refer to Table 1-2.

TABLE 1-2. BEAUFORT SCALE OF WIND FORCE

Description of wind		Specifications for use on land	MPH	m/s
0	Calm	Calm; smoke rises vertically.	0-1	0-0.2
1	Light Air	Direction of wind shown by smoke.	1-5	0.3-1.5
2	Light Breeze	Wind felt on face; leaves rustle; ordinary vanes moved by wind.	6-11	1.6-3.3
3	Gentle Breeze	Leaves and small twigs in constant motion; wind exceeds light flag.	12-19	3.4-5.4
4	Moderate Breeze	Raises dust and loose paper; small branches are moved.	20-28	5.5-7.9
5	Fresh Breeze	Small trees in leaf begin to sway; crested wavelets form on inland waterways.	29-38	8.0-10.7
6	Strong Breeze	Large branches in motion; whistling heard in telephone wires; umbrellas used with difficulty.	39-49	10.8-13.8
7	Near Gale	Whole trees in motion; inconvenience felt when walking against wind.	50-61	13.9-17.1
8	Gale	Breaks twigs off trees; generally impedes progress.	62-74	17.2-20.7
9	Strong Gale	Slight structural damage occurs (chimney pots and slates removed).	75-88	20.8-24.4

EXPLOSION HAZARD

- **NEVER** operate aerial work platform if you smell or detect Liquid Petroleum Gas (LPG), gasoline, diesel fuel or other explosive substances.
- **ALWAYS** charge Batteries only in an open, well-ventilated area away from sparks, flames and lighted tobacco.

If this aerial work platform is equipped with a generator:

- **NEVER** refuel with the engine running.
- **NEVER** operate engine unless in a well-ventilated area to avoid carbon monoxide poisoning.

MAINTENANCE

Ensure the following general safety precautions are followed while performing maintenance on the aerial work platform:

General Maintenance

ALWAYS perform maintenance procedures according to manufacturer's guidelines. **NEVER** disregard or bypass proper maintenance procedures.

ALWAYS inspect hydraulic system to ensure that all lines, connectors and fittings are properly fastened and are in good condition.

ALWAYS turn the key switch **OFF** and remove key before performing maintenance.

Whenever possible, **ALWAYS** perform maintenance with the telescoping boom and platform in a fully lowered, stowed position.

ALWAYS secure the telescoping boom before performing maintenance on hydraulic cylinders.

ALWAYS disconnect power to the hydraulic pump drive motor before making electrical checks to the hydraulic valves.

ALWAYS keep all mechanical parts properly adjusted and lubricated according to maintenance schedule and manufacturer / factory specifications. Refer to the "Equipment Maintenance" section of this manual.

ALWAYS perform a function check of operating controls before each use and after any repairs have been made.

ALWAYS locate and protect against possible pinch points before performing any maintenance or repairs.

ALWAYS use only manufacturer-approved parts to repair or maintain aerial work platform. If any portion of this aerial work platform is rebuilt or repaired, retesting is required in accordance with manufacturer / factory instructions.

ALWAYS maintain a safe distance while testing the hydraulic components. **ALWAYS** relieve hydraulic pressure before loosening or removing hydraulic components. **NEVER** test or operate the hydraulic components while personnel are near the aerial work platform.

NEVER allow water or foreign particles into the DC electric motor housing. Inclusion of water or foreign particles may cause serious damage to the motor. If the motor becomes wet, refer to the "Motor Drying Instructions" located in the Maintenance section of this manual for proper drying instructions.

NEVER add unauthorized fluids to the hydraulic system or battery. **NEVER** mix hydraulic oils. Consult manufacturer specifications. Refer to the "Equipment Maintenance" section of this manual for hydraulic system maintenance procedures.

NEVER exceed the manufacturer's recommended relief valve settings.

NEVER touch or allow metal tools to contact any components that are sensitive to static discharge. **ALWAYS** use static discharge prevention mats and grounding devices when handling electronic components.

NEVER adjust, repair, replace or bypass any hydraulic or electrical control or safety device. These include, but are not limited to; hydraulic load control and flow control valves, solenoid valves and limit switches. **ALWAYS** consult an authorized Haulotte Group technician if repairs are necessary.

NEVER modify, alter or change the aerial work platform without first consulting an authorized Haulotte Group service technician, and **NEVER** in any way that would affect its original design or operation.

MAINTENANCE SAFETY (CONTINUED)

Battery Maintenance

Ensure the following general safety precautions are followed when performing battery maintenance on the aerial work platform:

ALWAYS check the battery fluid level daily.

ALWAYS wear safety glasses when working with or near batteries.

ALWAYS avoid contact with battery acid. Battery acid causes serious burns and should be kept away from skin or eyes. If contact occurs, flush with water and consult a physician immediately.

ALWAYS disconnect ground cable first when removing battery.

ALWAYS connect ground cable last when installing battery.

ALWAYS charge batteries in open, well-ventilated areas.

ALWAYS replace batteries using only parts recommended by manufacturer / factory. **ALWAYS** use only batteries with sealed caps over cells.

NEVER smoke while servicing batteries.

NEVER charge batteries near flammable materials.

NEVER allow batteries to overcharge and boil.

NEVER short across battery posts to check for current. **NEVER** break a live circuit at the battery.

NEVER disconnect battery from charger while charger is connected to a live power source.

NEVER jump-start other vehicles using the aerial work platform batteries.

2 SPECIFICATIONS

The following information is based on ideal working conditions. Machine performance may vary based on work environment and on machine options.

Only one telescoping boom motion is permitted at a time and only as long as the telescoping boom is within the safe operating zone. When a selected telescoping boom motion exceeds a safe operating limit, the telescoping boom motion ceases and another telescoping boom motion must be selected within the safe operating zone. Refer to Figure 2-1.

RANGE OF MOTION

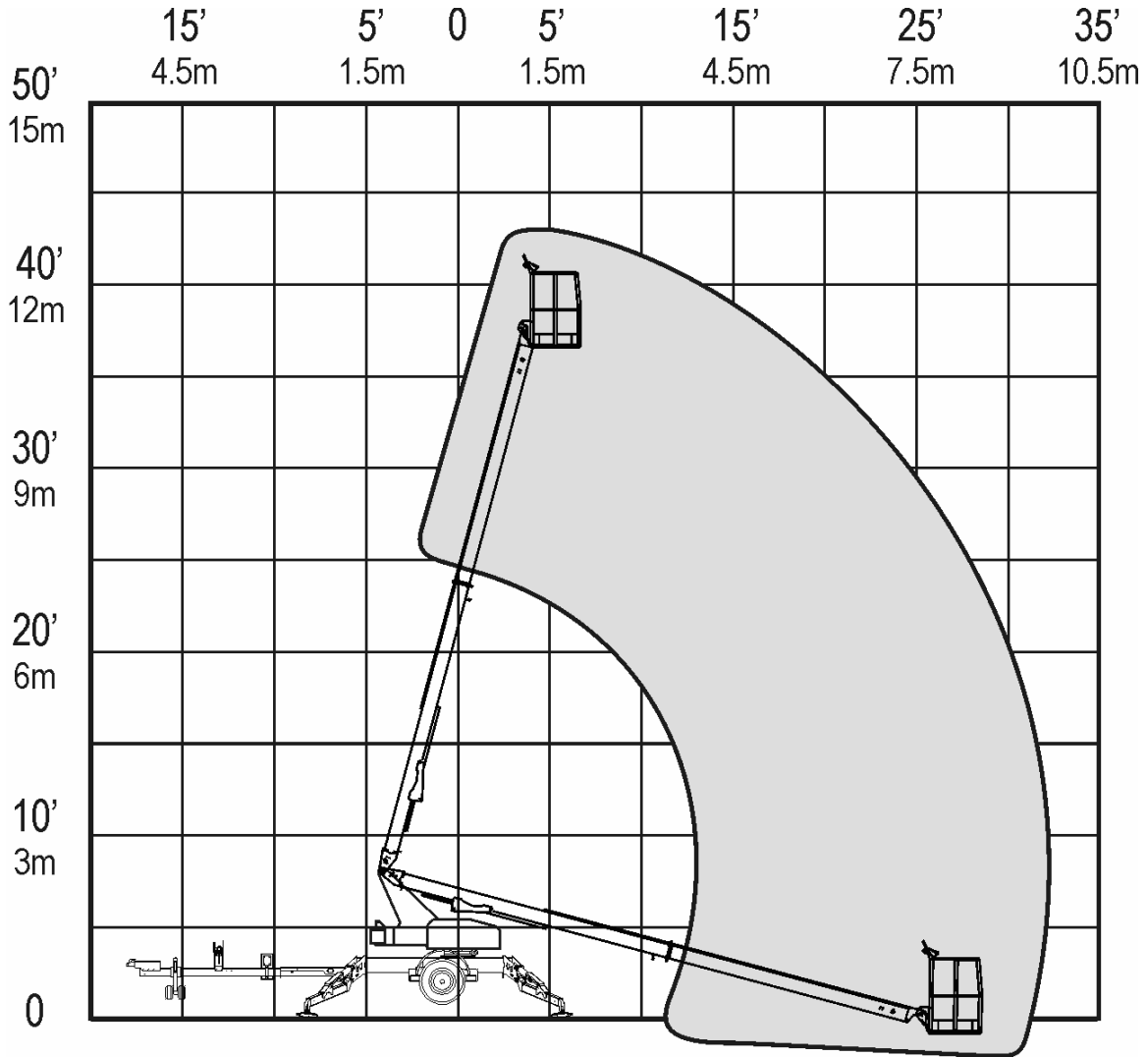

Figure 2-1. Range of Motion

SPECIFICATIONS		Serial Number _____
Maximum Working Height		43 ft 6 in (13.4 m)
Maximum Platform Height		37 ft 6 in (11.4 m)
Maximum Horizontal Outreach		
From Centerline		32 ft (9.8 m)
From Outrigger Footpad Edge		27 ft (8.2 m)
Rated Platform Capacity		
Without Platform Rotation		500 lb (227 kg)
With Platform Rotation		440 lb (200 kg)
Maximum Occupants		2
Total Weight		
Without Options		4,400 lb (1,996 kg)
With All Options		5,000 lb (2,268 kg)
Turntable Rotation		700° Non-Continuous
Leveling Capability		12.5°
Platform Dimensions		
Height		3 ft 7 in (1.1 m)
Length		2 ft 6 in (0.8 m)
Width		4 ft (1.2 m)
Stowed Dimensions		
Height		6 ft 5 in (2.0 m)
Length		21 ft 11 in (6.7 m)
Width		5 ft 5 in (1.7 m)
Outrigger Footprint (To Center of Pad)		
Length		12 ft 2 in (3.7 m)
Width		11 ft 4 in (3.4 m)
Footpad Diameter		12.5 in (0.3 m)
Parking Brake		Mechanical
Towing Brake		Hydraulic Surge / Electric
Rated Towing Speed		65 mph (105 km/h)
Tire Size		ST 225/75 R15D
Control System		24V DC
Battery		4 x 6V 245 amp-hr
Charger		
North America		110 Volt 60 Hz
International		220 Volt 50 Hz

SPECIFICATIONS (CONTINUED)

Hydraulic Pressure	3,000 psi (207 bar) (20,684 kPa)
Reservoir Capacity	4.8 Gallons (18.2 L)
Hydraulic System Capacity	7 Gallons (26.5 L)
Hydraulic Oil (Standard)	HVI AW32
Platform Rotation (Option)	90° / Manual
Maximum Decibel Level	
DC Mode – Ground	60 dBA
DC Mode – Platform	55 dBA
Engine Mode – Ground	70 dBA
Engine Mode – Platform	65 dBA
Function Speeds	
Boom Raise (Fast)	30-35 sec
Boom Raise (Slow)	50-55 sec
Boom Lower (Fast)	45-50 sec
Boom Lower (Slow)	120-150 sec
Boom Extend (Fast)	30-35 sec
Boom Extend (Slow)	75-90 sec
Boom Retract (Fast)	40-45 sec
Boom Retract (Slow)	100-110 sec
Turntable Rotation (Fast)	82-90 sec
Turntable Rotation (Slow)	240-270 sec
Platform Level (Fast)	8-10 sec
Platform Level (Slow)	12-16 sec
Outrigger Extend	15-20 sec
Outrigger Retract	25-30 sec
Localized Pressure per Outrigger	25 psi (1.8 kg/cm ²) (176.5 kPa)
Operating Temperature Range	-20° to 110° Fahrenheit (-29° to 43° Celsius)

WARRANTY - NEW PRODUCT; HAULOTTE NORTH AMERICA

Haulotte US Inc (Haulotte) warrants its new products made by it to be free from defects in material or workmanship for twelve (12) months under normal operational conditions from the warranty start date (delivery date).

In addition, Haulotte further warrants the structural elements of each new product made by it, as defined in its then current warranty policies and procedures, to be free from defects in material or workmanship for five (5) years from the warranty start date (delivery date).

Haulotte agrees to repair or replace at its own expense; at its facility in Frederick MD, or at an authorized repair facility designated by Haulotte, any part or parts of the product found to be defective in material or workmanship, provided Haulotte is notified of such defect or defects within the applicable warranty period and given a reasonable time to correct the defect. In no case shall any warranty extend to defects in materials, components, or services furnished by third parties. Defects caused by chemical action or the presence of abrasive materials and defects arising following the operation beyond rated capacity or the improper use or application of any products shall not be considered defects within the scope of this warranty. If any repairs or alterations are made or any parts are replaced during the applicable warranty periods by anyone other than Haulotte or an entity authorized by Haulotte for use in its products, customer shall pay for such repairs or parts without recourse against Haulotte, and Haulotte should be relieved of responsibility for fulfillment of this warranty with respect to such repairs, alterations, or replacement so made. Haulotte obligations under this warranty shall at all times be subject to its current warranty policies and procedures. The above mentioned warranty shall not apply to replacement or service parts made and sold by Haulotte. Periodic maintenance, periodic maintenance items (including paint and decals), and minor adjustments are excluded from this warranty. Certain components, including, but not limited to, engines, tires and batteries, which may be part of the product are not manufactured or warranted by Haulotte. Any applicable warranty for such component is provided through the original manufacturer of the component or its distributor organization. Haulotte warranty does not apply to defects caused by negligence, misuse, accidental damage, inadequate or improper use or maintenance, acts of nature and normal wear and tear of the products.

Under no circumstances shall Haulotte be liable for any consequential or special damages which any person or entity may incur or claim to incur as a result of any defect in the product or in any correction or alteration thereof made or furnished by Haulotte or others. Consequential or special damage includes, but not limited to cost of transportation, lost sales, lost orders, lost profits, lost income, increased over head, labor and material costs, and cost of manufacturing variances and operational inefficiencies. Haulotte maximum liability under this warranty shall be the purchase price paid to Haulotte with respect to the product to which such warranty is claimed. This warranty constitutes Haulotte entire and exclusive warranty as to the product and is the sole and exclusive remedy for the product defects in material and workmanship. Haulotte does not assume (and has not authorized any other person to assume on its behalf) any other warranty or liability in connection with any product covered by this warranty.

Haulotte expressly disclaims any and all other warranties of any kind whatsoever as to the product furnished hereunder, including but not limited to any express warranties, except for the exclusive warranty provided herein, or implied warranties as to merchantability, or fitness for any particular purpose.

This warranty shall be void, if, upon the occurrence of any incident involving any product made by Haulotte and resulting in any personal injury or property damage, customer shall fail to notify Haulotte within 48 hours of such occurrence or permit Haulotte and its representatives to have immediate access to such product and all records of or within the control of the customer relating to the product and occurrence. For the procedure to apply for warranty please refer to the warranty procedure (document # QC-00001).

North America Warranty 2010/4.

QC-00002

WARRANTY CLAIMS PROCEDURE

In order to qualify for warranty coverage, the following conditions must be met:

- 1) Return of completed "Warranty Registration" form to Haulotte Group|BilJax within 15 days of receipt of product;
- 2) Notification to Haulotte Group|BilJax Service within 48 hours of any claimed defect, or damage resulting from the claimed defect;
- 3) Warranty is limited to parts that are determined to be defective by an authorized service dealership in conjunction with Haulotte Group|BilJax Service. This does not include parts worn out due to normal wear and tear.

Haulotte Group|BilJax authorized dealers or distributors are responsible for filing claims under warranty. Listed below is the warranty claims procedure.

- 1) Contact Haulotte Group|BilJax Service at 1-(888)-440-9240 to report the claim and verify warranty coverage. Machine serial number and machine hours must be provided when call is placed. A call ID number will be created when the call is placed. The service representative will issue the call ID number to you at the end of the call.
- 2) Identify the components to be claimed under warranty along with description of failure. An RMA number will be issued from Haulotte Group|BilJax to return warranty parts at the time the parts order is placed.
- 3) Replacement parts will then be sent by Haulotte Group|BilJax to the dealer or distributor. All parts are invoiced at dealer|distributor list price. Credits will be issued when defective parts are returned to Haulotte Group|BilJax under the proper RMA number and found to be defective under warranty.
- 4) After completing repairs, submit warranty application form and return the defective parts to Haulotte Group|BilJax. Warranty application form and parts must be received within 30 days of claim in order to be eligible for credit. Returned parts are to be sent prepaid and will be credited when part is received and verified. Warranty labor rate will be paid at current rate set by Haulotte Group|BilJax. The amount of labor hours reimbursed will be determined by Haulotte Group|BilJax and will be limited to 4 hours unless approved by Haulotte Group|BilJax Service.
- 5) The warranty application must include; the issued RMA number, the invoice number for the associated parts, the machine serial number, the machine hours on the date of failure, the issued call ID number, failure and repair description, and requested customer information.

Failure to follow the warranty claims procedure may result in delay in processing claim or denial of the claim. Haulotte Group|BilJax reserves the right to limit or adjust warranty claims with regard to parts, labor, and travel time. Replacement components purchased from suppliers other than Haulotte Group|BilJax are not covered under the terms of this warranty.

QC-00001

DAMAGED EQUIPMENT POLICY

Safety Statement

At Haulotte Group we are dedicated to the safety of all users of our products. All Haulotte Group aerial work platforms are designed, manufactured and tested to comply with current applicable ANSI, CSA, AS and / or CE Standards and regulations.

Damage Policy

There may be occasions when a Haulotte Group aerial work platform is involved in an incident that results in structural damage to the aerial work platform. Such damage can seriously compromise the ability of the aerial work platform to perform in a safe manner. Therefore, whenever a Haulotte Group aerial work platform has sustained visual structural damage, or when there is suspected internal structural damage, Haulotte Group may require that the aerial work platform be returned to our facility for a complete inspection and recertification. For any questions concerning whether your aerial work platform may have sustained structural damage or the Damaged Equipment Policy, please contact an authorized Haulotte Group representative or your regional Haulotte Group dealer.

Damage Repair Notice

There may be occasions when a Haulotte Group aerial work platform is involved in an accident resulting in damage to non-structural components. When such damage occurs and repairs are made by the owner or area distributor, please notify Haulotte Group of these non-maintenance repairs and request a repair form to be filled out and returned to Haulotte Group.

3 EQUIPMENT MAINTENANCE

Performing the appropriate maintenance procedures will extend the life of the aerial work platform and will help ensure the safety of personnel operating the equipment.

Repair, replacement or adjustment of any hydraulic or electrical control device should be performed only by fully trained and authorized personnel. These include, but are not limited to, hydraulic load valves, hydraulic flow control valves, solenoid valves, and limit switches. These are safety related controls. Improper adjustment or tampering with these devices may impair aerial work platform function and result in safety or damage hazards.

Persons performing maintenance or repairs on the aerial work platform should be trained in accordance with the manufacturer's recommendations. Contact your regional Haulotte Group representative if additional information is needed.

Critical or suspect areas identified during any scheduled inspection of the aerial work platform shall be examined by qualified personnel in accordance with applicable Government regulations.

NEVER operate the aerial work platform if a defect or malfunction is identified or suspected. All defects and malfunctions must be repaired, and all maintenance performed, before returning an aerial work platform to service.

It is the practice of Haulotte Group to issue Service and / or Safety Bulletins, which may include updates to the information contained in this manual. In such instances, procedures contained in Haulotte Group Service Bulletins or Safety Bulletins supersede the information contained in manual.

BATTERY RECHARGE

Recharge aerial work platform batteries after each 8-hour work shift or as needed. When the aerial work platform is not in use, batteries should be recharged at least once per week. Under normal circumstances, battery recharge should take approximately 10-12 hours. However, a full recharge may take up to 24 hours, if the battery charge is extremely low.

WARNING

Recharge batteries in a well-ventilated area only. **DO NOT** charge batteries near fire, spark or other potential ignition sources. Batteries may emit highly explosive Hydrogen gas while charging. Failure to properly ventilate the charge gases could result in death or serious injury. Always charge aerial work platform batteries away from flammable materials.

To recharge the aerial work platform batteries:

- Move the aerial work platform to a well-ventilated area with direct access to a 120 VAC electrical outlet. Keep the aerial work platform and batteries away from open flame or other potential ignition sources.
- Attach a 12 AWG multi-strand, grounded Extension Cord with a maximum length of 50 feet (15 meters) to the receptacle located on the cargo plate in front of the turntable.

NOTE: Using an underrated or long power cord will reduce the output of the battery charger and may extend charge time.

- Plug the extension cord into outlet. Verify that the green **CHARGING** indicator LED is lit on the battery charger faceplate. Refer to Figure 3-1.
- The **CHARGING** indicator LED remains lit continuously during the first stage of the charge cycle. The bulk mode **CHARGE CURRENT** will be displayed on the Battery Charger Faceplate.
- Press and hold the Battery Voltage button to display the detected battery voltage.

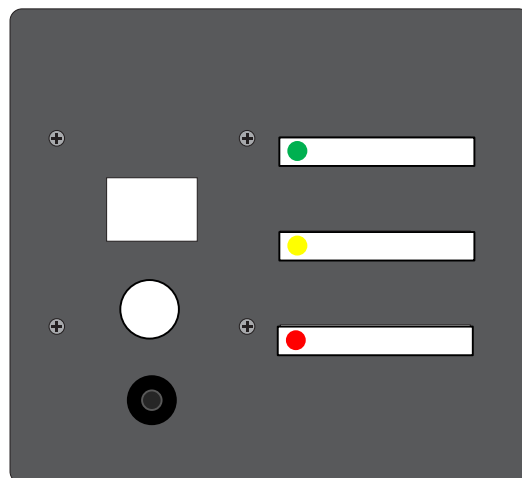



Figure 3-1. Battery Charger Faceplate

BATTERY RECHARGE (CONTINUED)

- If a Battery error is detected, the appropriate error code will appear on the charge current display. The red check battery indicator LED will become lit. See Table 3-1 for battery charger error codes.



WARNING

Do Not disconnect any output leads or connectors between the batteries and the charger when the charger is on. To stop a charge in progress, always unplug the extension cord from the AC Power source.

- When the battery charge reaches 80% of capacity, the yellow 80% **CHARGED** indicator LED will become lit and the green **CHARGING** indicator LED will begin to flash.
- When the batteries have reached a full charge, the green and yellow indicator LEDs will turn themselves off. CC (Charge Complete) will appear on the **CHARGE CURRENT** display. After two hours, this display will fade and the **CHARGE CURRENT** will read 00.
- Unplug the extension cord from the outlet and the charger receptacle on the aerial work platform. Store the extension cord for next use.

Code	Description	Limits	Cause
F0	No Battery	<10 volts	Loose connection or battery missing
F1	Over Voltage	>112% charge voltage	Connected to wrong battery voltage
F2	Over Current	>60 amperes	Operating machine while charging
F3	Bulk Mode Timeout	<80% charge at 16 hrs.	Battery fault
F4	ARD Mode Timeout	>80% and <full charge after 6 hrs Max.	Battery fault
F9	Current Measurement Error Standby		Board fault or charger exposed to extreme cold
FA	Triac Error		Board shorted
FF	Full Power to Transformer, No Current Output		Battery shorted or low AC line voltage or charge fault
CO	Charger Off		Charger resting between pulses (AGM batteries only)
CC	Charge Mode Complete		Batteries charged

NOTICE

Always unplug the battery charger power cord before moving the aerial work platform. Failure to disconnect power cord could cause damage to the equipment.

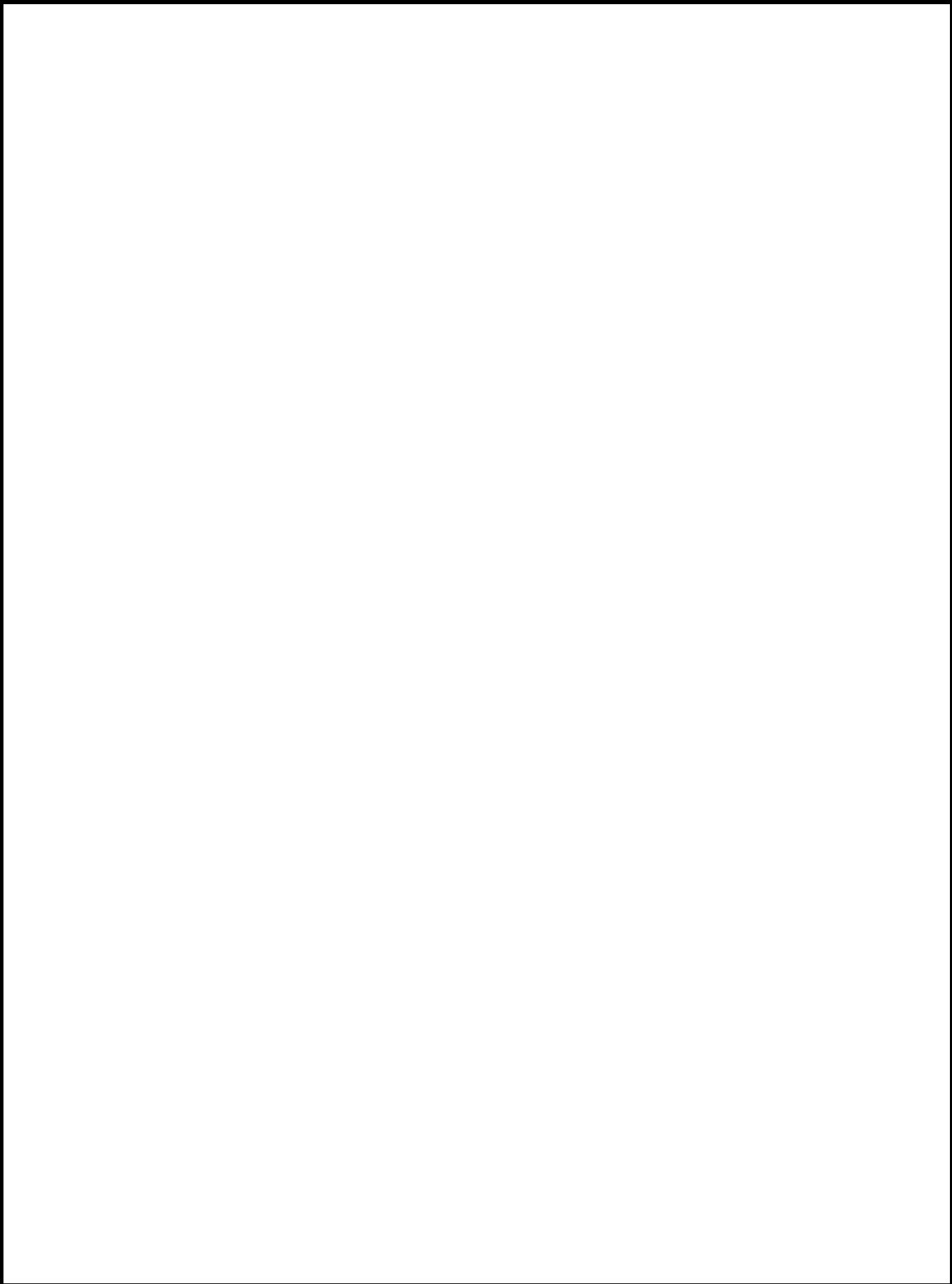

DAILY SERVICE CHECKS

The following Maintenance Procedures should be performed daily or before each operation:

Verify that all decals are correctly applied and in plain view.

Refer to the “Decal Replacement” Section of this Manual for decal locations.

Verify that all controls and indicators at ground and platform control stations operate properly.

- Lower outriggers to level the aerial work platform.
- Raise and extend the telescoping boom.
- Press **EMERGENCY STOP** button. This will deactivate all functions.
- Verify that the telescoping boom remains elevated and does not drift.
- Pull out **STOP** button and lower the telescoping boom.
- Operate drive functions from the platform control station to confirm proper operation for applicable machines.
- If either control station is unresponsive, refer to the Trouble Shooting procedures.
- If the Display Panel displays an error code, refer to the Control Panel Error Code definitions. Table 3-3 is located later in this section.
- If the Motor Controller’s Green light is flashing there is an error, refer to the Motor Controller Error Code Definitions. Table 3-4 is located later in this section.

Verify correct operation of turn signals, brakes and running lights.

Verify proper tire inflation. See side wall of tire for proper inflation.

Inspect tires for damage or loose or missing lug nuts.

- Repair or replace as necessary.

Inspect structural components and platform for obvious damage or debris.

- Repair or replace as necessary.

Inspect the aerial work platform for missing, loose or damaged fasteners, including pins and bolts.

Verify that the telescoping boom down limit switches operate correctly.

- Down limit switches are actuated when the telescoping boom is in a fully lowered, stowed position. Limit switches must be operational to raise or lower outriggers.
- If outrigger controls are unresponsive when the telescoping boom is fully lowered and stowed, inspect down limit switches for loose mounting or visible damage.
- Repair or replace as necessary.

DAILY SERVICE CHECKS (CONTINUED)

Verify that outrigger safety interlocks operate correctly.

- Begin with the outriggers fully extended and the aerial work platform level. Raise one outrigger until the footpad is not in contact with the ground.
- Verify that boom functions are unresponsive when one outrigger is raised.
- Repeat this procedure for each outrigger.
- Raise all outriggers until the footpads are not in contact with the ground. Verify that all outrigger status LEDs on the ground control panel are **unlit**.
- Lower one outrigger until the footpad makes contact with the ground and the outrigger begins lifting the trailer.
- If the LED is lit before the footpad makes contact with the ground or if the LED remains unlit after the weight is transferred to the outrigger, the position switch or wiring is faulty. Refer to Figure 3-2.
- Repeat this procedure for each outrigger. Repair or replace as necessary.

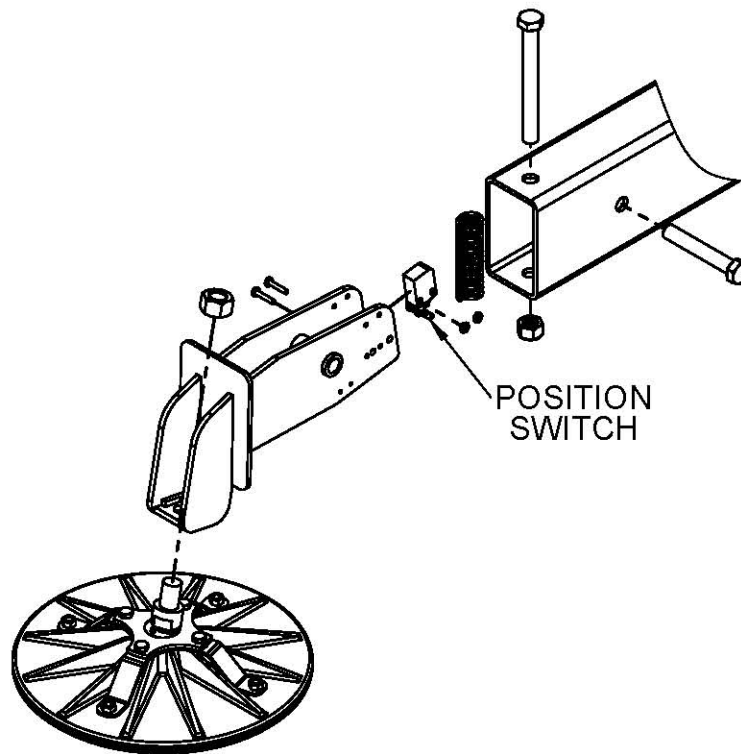

Figure 3-2. Outrigger Position Switches

DAILY SERVICE CHECKS (CONTINUED)

Inspect hydraulic System and fluid levels.

- Check all hydraulic hoses and fittings for leaks and / or damage. Tighten or replace as necessary to prevent hydraulic oil or pressure loss.
- The hydraulic oil level should be checked with the telescoping boom down, all outriggers raised and the trailer wheels on a level surface.
- Hydraulic oil level should be visible in, but not above, the sight gauge.
- If the hydraulic oil level is not visible to at least half way up the sight gauge, add clean Hydraulic Fluid as necessary while all telescoping boom and outriggers are fully retracted and stowed. Pour slowly to avoid creating air pockets in the reservoir. **Do Not** fill above sight gauge. Overfilling the hydraulic reservoir may cause damage to hydraulic lines and may result in aerial work platform malfunction. Refer to Figure 5-2.
- The hydraulic reservoir is originally filled with HVI AW32 Hydraulic Oil.
- A minimum Viscosity Index of 175 is recommended for this aerial lift platform.

NOTICE

Do Not mix hydraulic oils. Do Not add any fluid to the hydraulic system that is not expressly recommended by the manufacturer. Adding unauthorized fluids to the hydraulic system could cause damage to the aerial work platform.

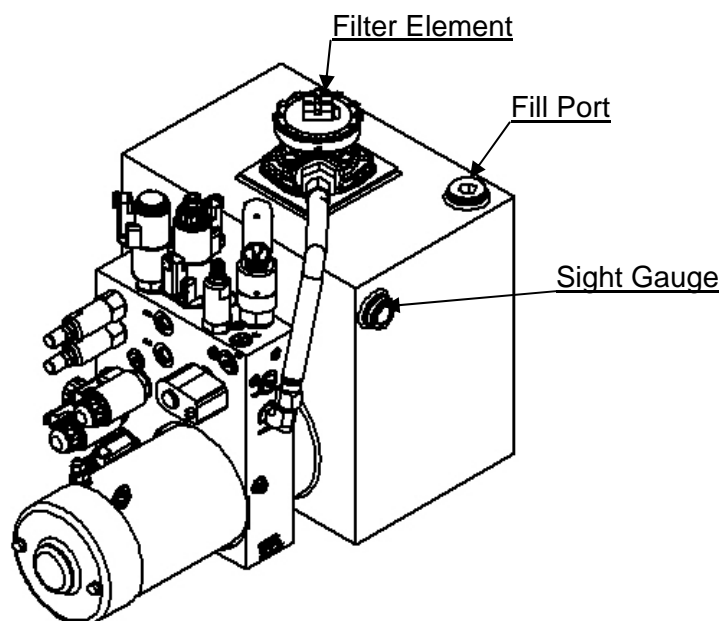

Figure 3-3. Hydraulic Reservoir

WEEKLY SERVICE CHECKS

Perform the following service checks at least once each week in addition to all recommended Daily Service Checks:

Check Battery Electrolyte level.

- If battery charge is low, add enough distilled water to bring the electrolyte level to the top of the plates.
- If batteries are fully charged, raise electrolyte level to full mark in each cell.

Inspect all electrical wiring.

- Check for cuts, loose terminals, broken wires, chaffing and corrosion.
- Repair all damage, remove corrosion and seal exposed connections.

Inspect transport hitch components for damage. Applicable to trailer mounted aerial lift platforms only.

Inspect the aerial work platform for missing, loose or damaged hardware.

- Repair or replace as necessary.

Inspect all hydraulic system components including the power unit, hoses and cylinders for damage, leaks, loss of pressure or speed, and unusual noise or vibration.

- Repair or replace as necessary.

MONTHLY SERVICE CHECKS

Perform the following service checks at least once each month:

Check battery for loose connections or damaged wires.

Clean all battery terminals.

Verify proper operation of manual lowering valves and hand pump.

- For manual boom operating procedures, refer to the “Operation” section of the Operation Manual.

Lubricate slew ring and mating gear.

- Use NLGI Grade 2 multi-purpose grease.

Check wheel nut torque.

- For correct wheel nut tightening sequence, refer to Figure 3-4.
- Evenly tighten wheel nuts to 25 lb-ft (34 N-m) in the tightening sequence shown.
- Repeat tightening sequence, tighten wheel nuts to 60 lb-ft (81 N-m) and then to 100 lb-ft (136 N-m).

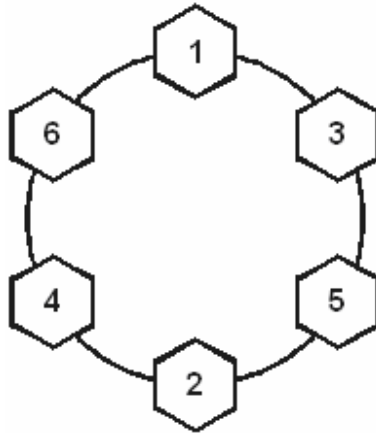

Figure 3-4. Wheel Nut Tightening Sequence

NOTICE

When wheels are newly installed or replaced, verify wheel nut torque monthly. Follow this procedure each time the wheel is removed and reinstalled. Improperly torqued wheel nuts could result in wheel separation, pre-mature tire wear, or damage to the equipment.

Check parking brakes.

Refer to the “Set up and Adjustment” section located in the Axle and Related Components section of this Manual for more detailed information.

MONTHLY SERVICE CHECKS (CONTINUED)

Verify that Level Sensor is operating correctly.

- Fully deploy outriggers until all outrigger LEDs and **AUTO LEVEL** LED's are lit, and the buzzer at the ground station sounds.
- Verify that the aerial work platform is level, and that the level sensor is giving an accurate reading.
- Repair or replace as necessary.

For aerial work platforms with material hook option:

- Verify the weight reading displayed at the ground control station is within 10% of actual weight tested. Recalibrate load cell if needed. See the "Load Cell Calibration" procedure located in the "Optional Equipment" section.

ANNUAL SERVICE CHECKS

Perform the following service checks at least once each year:

Replace Hydraulic Oil and Oil Filter.

- Wipe away dirt and excess oil from the area around the power unit, hoses and filter(s) using cleaning cloths and alcohol solvent.
- Drain reservoir by removing the hex plug located on the bottom side of the reservoir.
- After oil is drained, remove oil filter(s) from top of tank.
- Re-Install the filter being careful not to introduce any debris into the system. Do not over-tighten.
- Replace oil with HVI AW32 or equivalent AW32 Hydraulic oil.
- With the fill port cap on but not tightened, completely raise and lower the telescoping boom to bleed trapped air from the lift cylinders. Repeat as necessary.
- Repeat every 100 hours, or annually, which ever comes first.

Inspect pivot pins and cylinders, including rod ends, for wear or damage. Replace as necessary.

Visually inspect welds and structural components for wear, damage and corrosion.

- Follow all manufacturers' recommendations when making repairs to critical components.
- Personnel making repairs to welds should be certified in accordance with applicable Government regulations.

Inspect outriggers for wear or damage. Repair or replace as necessary.

Inspect and adjust axle and parking brakes.

- Refer to the "Axle and Related Components" section in the back of this manual for a partial reprint of the Dexter Operation Manual.

Load test telescoping boom lift operations with 500 lb (227 kg) load.

ANNUAL SERVICE CHECKS (CONTINUED)

Check slew bearing for wear or damage.

- Deploy the outriggers using the **AUTO LEVEL** and **EXTEND** buttons on the ground (lower) control panel. The tires will be slightly off the ground in this position.
- Place a 175 lb (65 kg) load in the platform and raise the boom to the full out position. Refer to Figure 3-5.

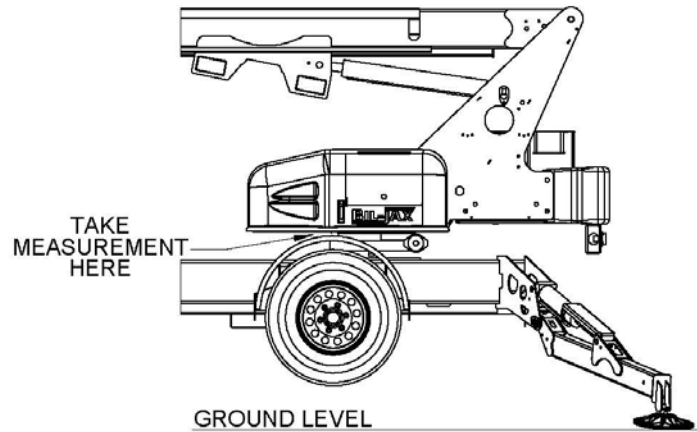

Figure 3-5. Machine Position for Slew Ring Measurement

- Measure the distance between the slew ring gear and the horizontal plate above, using a 2 inch (50 mm) caliper or bore micrometer. Refer to Figure 3-5.

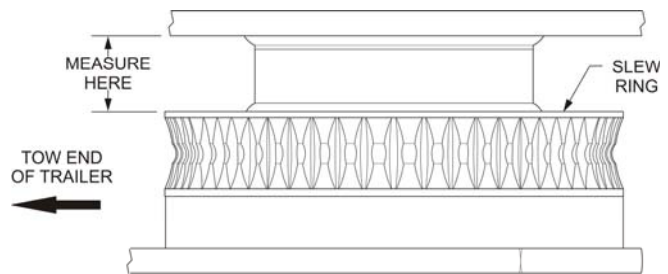

Figure 3-5. Slew Ring Position Measurement

- Record the measurement.
- Rotate the platform 180° and re-record the measurement. Refer to Figure 3-6
- If the difference in measurements is greater than 0.25 in (6.35 mm) the slew ring bearing should be replaced. Contact Haulotte Group Customer Service Department: at 1-800-537-0540 or visit Haulotte Group online at www.haulotte-usa.com for additional information.

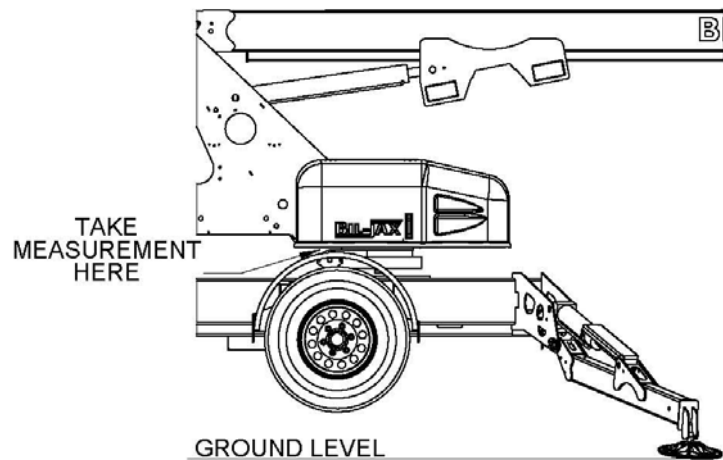

Figure 3-5. Slew Ring Position Measurement

STRUCTURAL INSPECTION

A comprehensive structural inspection of the unit shall be performed under any of the following conditions:

- Ten years from the date of manufacture and every five years thereafter.
- After any actual, suspected or potential damage is sustained that could affect the structural integrity or stability of the aerial work platform.
- After a change in ownership. Owners should provide a complete service history when reselling the unit. The structural inspection shall include the following considerations:
 - The service history of the unit, including hours of service, work performed and environmental conditions.
 - The inspection and maintenance record of the aerial work platform.
 - The effectiveness of all controls and components.
 - A visual inspection of the aerial work platform for wear or damage.
 - Manufacturer recommendations.
 - A visual weld inspection, to be performed by qualified personnel in accordance with applicable Government regulations.

MOTOR DRYING INSTRUCTIONS

Inclusion of water or foreign particles into the DC electric motor housing may cause serious damage to the motor. If the motor becomes wet, follow these instructions or contact an authorized Haulotte Group service technician

- Remove brush cover band
- Blow warm air into motor using a heat gun.
- Spray electrical contact cleaner solution into motor armature area.
- Replace brush cover band

ADDITIONAL SERVICE INFORMATION

Seals on hydraulic cylinders should be replaced every five years or as indicated by aerial work platform performance.

All service checks should be performed on an aerial work platform that has been stored without use for a period exceeding thirty (30) days.

Check for air in the hydraulic system if the aerial work platform has been stored without use for a period exceeding thirty (30) days, or if the aerial work platform was stored without use during a seasonal climate change. Air trapped in the hydraulic system will affect aerial work platform performance. Follow procedures for bleeding air from the hydraulic system, found in the "Cylinder Replacement" section (next section) of this manual.

Owners and lessors should complete a full inspection of all components and perform a test of all functions, including brake functions, before commissioning or reselling the aerial work platform. Always repair or replace all damaged or malfunctioning components before commissioning or reselling an aerial work platform.

When a change in ownership occurs, it is the responsibility of the seller to provide the new owner with all manuals for the aerial work platform. It is the responsibility of the buyer to notify the manufacturer of the unit model and serial number and the name and address of the new owner within sixty (60) days of the purchase.

Use the service checklists found at the back of this manual to record all service checks as well as any maintenance, repairs or alterations performed on the aerial work platform.

Records of frequent safety checks need not be made. However, where a safety hazard is found, it shall be reported in writing to the owner of the aerial work platform, and a record of any corrective action shall be maintained for five years or as required by the authority having jurisdiction.

Testing Aerial Work Platform Stability

The Summit Series aerial work platform has been tested for stability using a load equal to 150% of the rated capacity of the machine and placed at the center of the platform with the telescoping boom fully extended.



Stability tests should be conducted only by trained personnel and only when the machine is properly anchored to safeguard against tipping. Failure to anchor the machine could result in death or serious injury and damage to the machine.

TROUBLESHOOTING

Refer to the following Table for basic Troubleshooting Operations. Contact the Haulotte Group Service Department with any questions or before attempting any advanced troubleshooting operations.

TABLE 3-2. TROUBLE SHOOTING

PROBLEM	CAUSE	SOLUTION
No lights on panel when key switch is turned to the on position.	<ul style="list-style-type: none"> a. EMERGENCY STOP engaged. b. Battery charge is low. c. Battery ground or in-series cable is loose. d. Battery main disconnect unplugged. e. Blown Fuse 	<ul style="list-style-type: none"> a. Disengage EMERGENCY STOP buttons. b. Recharge as needed. c. Inspect and repair battery connections. d. Plug in main disconnect. e. Replace Fuse as necessary.
Error code displayed on Ground Control Panel.	<ul style="list-style-type: none"> a. Error detected by Control Box. 	<ul style="list-style-type: none"> a. Refer to Error Code Definitions, Table 3-3.
Green light flashing on Motor Controller.	<ul style="list-style-type: none"> a. Error detected by Motor Controller. 	<ul style="list-style-type: none"> a. Refer to Motor Controller Error Code Definitions, Table 3-4.
Hydraulic function does not work and display window shows an error message.	<ul style="list-style-type: none"> a. Error detected by safety interlock microprocessor. b. Aerial work platform electric or electronic failure. 	<ul style="list-style-type: none"> a. Refer to error code definitions, Table 3-3. b. Refer to error code definitions, Table 3-3.
Outrigger indicator LED lights do not function.	<ul style="list-style-type: none"> a. Key switch turned to the OFF or platform controls position. b. EMERGENCY STOP engaged. c. Outriggers not deployed. 	<ul style="list-style-type: none"> a. Turn key switch to ground controls position. b. Disengage EMERGENCY STOP buttons. c. Deploy all outriggers.
<p>One or more telescoping boom controls do not function.</p> <p>OR</p> <p>One or more Telescoping Boom Controls function improperly.</p> <p>OR</p> <p>One or more Telescoping Boom Controls function intermittently.</p>	<ul style="list-style-type: none"> a. Key switch is turned to the OFF or incorrect control position. b. Battery charge is low. c. EMERGENCY STOP engaged. d. Battery ground or in-series cable loose. e. All outriggers not properly deployed. f. Hydraulic pump inoperative. g. Loose wiring connector. h. Valve solenoid not operating properly. i. Error detected by system interlock. j. Broken or loose wire. 	<ul style="list-style-type: none"> a. Turn key switch to ground or platform controls position. b. Recharge battery. c. Disengage EMERGENCY STOP buttons. d. Inspect and repair battery connections. e. Deploy all outriggers and level aerial work platform. f. Inspect pump; replace or repair as needed. g. Check wiring terminals in control box and at valve manifold; replace or repair as needed. h. Clean valve solenoid and recheck function(s); replace or repair as needed. i. Check display for system status. See Table 3-3 for error code definitions and correction. j. Inspect wiring in control box and at valve manifold and valve coil; repair or replace as needed.

ERROR CODE DEFINITIONS – CONTROLS

The DISPLAY PANEL located on the Ground Control Panel indicates the present operating status of the aerial work platform. If an error condition is detected, the appropriate error code will be displayed on this panel. Refer to Table 3-3 to resolve the error.

TABLE 3-3. ERROR CODE DEFINITIONS

ERROR MESSAGE	ERROR DEFINITION	TO SIMULATE ERROR	TO CLEAR ERROR	COMMENTS
001 MACHINE IS IN DOWN ONLY MODE	Machine went out of level with use, moment sense or load sense circuits have detected an overload	Level machine, raise boom and tilt level sensor	This is a self clearing error. When error condition is corrected, error is cleared	Error will be displayed only if boom is raised
002 LOSS OF PLATFORM COMMUNICATION	Lower Control has lost RS485 communication with Platform Control	Open Platform Control and remove green wire from J1	This is a latched error. Power must be cycled to clear error	The Platform Control "Engine On" LED will also blink a 2 blink error code.
003 LOSS OF DRIVE COMMUNICATION	Lower Control has lost RS485 communication with Drive Control	Open Drive Control and remove green wire from J1	This is a latched error. Power must be cycled to clear error	Machines with Drive option only. The Drive Control "Engine On" LED will also blink a 2 blink error code.
004 LOSS OF PC COMMUNICATION	Lower Control has lost RS232 communication with PC	Connect a PC without running the configuration program	This is a self clearing error. When error condition is corrected, error is cleared	Error message will only be display if connected to a PC that is not communicating.
005 PLATFORM CONTROL HAS STUCK KEY	Platform Control has detected a stuck or pressed key on power up	On Platform Control hold down a key at power up	This is a latched error. Power must be cycled to clear error	The Platform Control "Engine On" LED will also blink a 1 blink error code.
006 DRIVE CONTROL HAS STUCK KEY	Drive Control has detected a stuck or pressed key on power up	On Drive Control hold down a key at power up	This is a latched error. Power must be cycled to clear error	Machines with Drive option only. The Drive Control "Engine On" LED will also blink a 1 blink error code.
007 DRIVE CONTROL HAS STUCK JOYSTICK	Drive Control has detected a stuck or pressed joystick on power up	On Drive Control hold joystick to side at power up	This is a latched error. Power must be cycled to clear error	Machines with Drive option only. The Drive Control "Engine On" LED will also blink a 3 blink error code.
008 GROUND CONTROL HAS STUCK KEY	Lower Control has detected a stuck or pressed key on power up	On Lower Control hold down a key at power up	This is a latched error. Power must be cycled to clear error	The Lower Control "Power" LED will also blink a 1 blink error code.
009 BOOM UP WITHOUT OUTRIGGERS ON GROUND	Lower Control has detected the boom is up and all four outriggers are not on the ground	Disconnect a wire from either the boom down or any outrigger switch and turn on machine	This is a self clearing error. When error condition is corrected, error is cleared	
010 LEVEL SENSOR HAS ERRATIC OUTPUT	The Lower Control has detected an erratic output from the level sensor	Shaking the level sensor after machine has been leveled	This is a self clearing error. When error condition is corrected, error is cleared	This error is suppressed during extending and retracting outriggers
011 TRYING TO DRIVE W/ TRAILER BRAKE OFF	An attempt was made to drive machine without engaging the trailer brake	Trying to drive machine with trailer brake off	This is a self clearing error. When error condition is corrected, error is cleared	Machines with Drive and Set option only
012 ANGLE SENSOR IS DISCONNECTED OR BAD	Angle sensor output is out of range	Disconnect Angle Sensor	This is a self clearing error. When error condition is corrected, error is cleared	Machines with Moment Sense option only
013 PRESSURE SENSOR IS DISCONNECTED OR BAD	Pressure sensor output is out of range	Disconnect Pressure Sensor	This is a self clearing error. When error condition is corrected, error is cleared	Machines with Moment Sense option only

TABLE 3-3. ERROR CODE DEFINITIONS

ERROR MESSAGE	ERROR DEFINITION	TO SIMULATE ERROR	TO CLEAR ERROR	COMMENTS
014 CHECK ENGINE LOW OIL PRESSURE	Engine had low oil pressure while running	Kawasaki Engine: While engine is running, disconnect engine oil pressure sense wire Kubota Engine: While engine is running, disconnect engine oil pressure sense wire and connect wire to ground	This is a latched error. Power must be cycled to clear error	X-Boom Machines with Kawasaki or Kubota engines
015 MACHINE IS NOT LEVEL	Machine has gone out of level with use	Tilt level sensor	This is a self clearing error. When error condition is corrected, error is cleared	
016 LIFT BOOM	A Boom Rotate, Extend or Retract function has been requested while boom is down	Try to Rotate, Extend or Retract the boom while boom is down	This is a self clearing error. When error condition is corrected, error is cleared	
017 STOW BOOM	An Outrigger function has been requested while boom is up	Try to move an outrigger while boom is up	This is a self clearing error. When error condition is corrected, error is cleared	
018 LOSS OF LOAD SENSE COMMUNICATION	Lower Control has lost RS485 communication with Load Sense Module	Remove Load Sense Module from machine	This is a latched error. Power must be cycled to clear error	Machines with Load Sense option only
019 BOOM FUNCTION DISABLED	Load Sense Module has detected an overloaded boom and disabled boom functions	Overload Boom	This is a latched error. Power must be cycled to clear error	Machines with Load Sense option only
020 LOSS OF LOAD CELL CONNECTION	Load Sense Module has lost connection with Load Cell	Disconnect Load Cell from Load Sense Module	This is a self clearing error. When error condition is corrected, error is cleared	Machines with Load Sense option only
021 OPEN CIRCUIT PRIMARY UP	A load of less than 70mA was detected when Primary Up circuit was energized	Disconnect a wire from Primary Up coil	This is a latched error. Power must be cycled to clear error	Checked only at power up
022 SHORTED CIRCUIT PRIMARY UP	Excessive load was detected when Primary Up circuit was energized	Use a piece of wire to short the Primary Up coil	This is a latched error. Power must be cycled to clear error	Checked only at power up
023 OPEN CIRCUIT PRIMARY DOWN	A load of less than 70mA was detected when Primary Down circuit was energized	Disconnect a wire from Primary Down coil	This is a latched error. Power must be cycled to clear error	Checked only at power up Articulating Boom Models
024 SHORTED CIRCUIT PRIMARY DOWN	Excessive load was detected when Primary Down circuit was energized	Use a piece of wire to short the Primary Down coil	This is a latched error. Power must be cycled to clear error	Checked only at power up Articulating Boom Models
025 OPEN CIRCUIT SECONDARY UP	A load of less than 70mA was detected when Secondary Up circuit was energized	Disconnect a wire from Secondary Up coil	This is a latched error. Power must be cycled to clear error	Checked only at power up Articulating Boom Models
026 SHORTED CIRCUIT SECONDARY UP	Excessive load was detected when Secondary Up circuit was energized	Use a piece of wire to short the Secondary Up coil	This is a latched error. Power must be cycled to clear error	Checked only at power up Articulating Boom Models
027 OPEN CIRCUIT SECONDARY DOWN	A load of less than 70mA was detected when Secondary Down circuit was energized	Disconnect a wire from Secondary Down coil	This is a latched error. Power must be cycled to clear error	Checked only at power up Articulating Boom Models

TABLE 3-3. ERROR CODE DEFINITIONS

ERROR MESSAGE	ERROR DEFINITION	TO SIMULATE ERROR	TO CLEAR ERROR	COMMENTS
028 SHORTED CIRCUIT SECONDARY DOWN	Excessive load was detected when Secondary Down circuit was energized	Use a piece of wire to short the Secondary Down coil	This is a latched error. Power must be cycled to clear error	Checked only at power up Articulating Boom Models
029 OPEN CIRCUIT JIB UP	A load of less than 70mA was detected when Jib Up circuit was energized	Disconnect a wire from Jib Up coil	This is a latched error. Power must be cycled to clear error	Checked only at power up Articulating Boom Models
030 SHORTED CIRCUIT JIB UP	Excessive load was detected when Jib Up circuit was energized	Use a piece of wire to short the Jib Up coil	This is a latched error. Power must be cycled to clear error	Checked only at power up Articulating Boom Models
031 OPEN CIRCUIT JIB DOWN	A load of less than 70mA was detected when Jib Down circuit was energized	Disconnect a wire from Jib Down coil	This is a latched error. Power must be cycled to clear error	Checked only at power up Articulating Boom Models
032 SHORTED CIRCUIT JIB DOWN	Excessive load was detected when Jib Down circuit was energized	Use a piece of wire to short the Jib Down coil	This is a latched error. Power must be cycled to clear error	Checked only at power up Articulating Boom Models
033 OPEN CIRCUIT EXTEND	A load of less than 70mA was detected when Extend circuit was energized	Disconnect a wire from Extend coil	This is a latched error. Power must be cycled to clear error	Checked only at power up
034 SHORTED CIRCUIT EXTEND	Excessive load was detected when Extend circuit was energized	Use a piece of wire to short the Extend coil	This is a latched error. Power must be cycled to clear error	Checked only at power up
035 OPEN CIRCUIT RETRACT	A load of less than 70mA was detected when Retract circuit was energized	Disconnect a wire from Retract coil	This is a latched error. Power must be cycled to clear error	Checked only at power up
036 SHORTED CIRCUIT RETRACT	Excessive load was detected when Retract circuit was energized	Use a piece of wire to short the Retract coil	This is a latched error. Power must be cycled to clear error	Checked only at power up
037 OPEN CIRCUIT PLATFORM LEVEL UP	A load of less than 70mA was detected when Platform Level Up circuit was energized	Disconnect a wire from Platform Level Up coil	This is a latched error. Power must be cycled to clear error	Checked only at power up
038 SHORTED CIRCUIT PLATFORM LEVEL UP	Excessive load was detected when Platform Level Up circuit was energized	Use a piece of wire to short the Platform Level Up coil	This is a latched error. Power must be cycled to clear error	Checked only at power up
039 OPEN CIRCUIT PLATFORM LEVEL DOWN	A load of less than 70mA was detected when Platform Level Down circuit was energized	Disconnect a wire from Platform Level Down coil	This is a latched error. Power must be cycled to clear error	Checked only at power up
040 SHORTED CIRCUIT PLATFORM LEVEL DOWN	Excessive load was detected when Platform Level Down circuit was energized	Use a piece of wire to short the Platform Level Down coil	This is a latched error. Power must be cycled to clear error	Checked only at power up
041 OPEN CIRCUIT PLATFORM CW	A load of less than 70mA was detected when Platform CW circuit was energized	Disconnect a wire from Platform CW coil	This is a latched error. Power must be cycled to clear error	Checked only at power up Articulating Boom Models
042 SHORTED CIRCUIT PLATFORM CW	Excessive load was detected when Platform CW circuit was energized	Use a piece of wire to short the Platform CW coil	This is a latched error. Power must be cycled to clear error	Checked only at power up Articulating Boom Models
043 OPEN CIRCUIT PLATFORM CCW	A load of less than 70mA was detected when Platform CCW circuit was energized	Disconnect a wire from Platform CCW coil	This is a latched error. Power must be cycled to clear error	Checked only at power up Articulating Boom Models

TABLE 3-3. ERROR CODE DEFINITIONS

ERROR MESSAGE	ERROR DEFINITION	TO SIMULATE ERROR	TO CLEAR ERROR	COMMENTS
044 SHORTED CIRCUIT PLATFORM CCW	Excessive load was detected when Platform CCW circuit was energized	Use a piece of wire to short the Platform CCW coil	This is a latched error. Power must be cycled to clear error	Checked only at power up Articulating Boom Models
045 OPEN CIRCUIT TURNTABLE CW	A load of less than 70mA was detected when Turntable CW circuit was energized	Disconnect a wire from Turntable CW coil	This is a latched error. Power must be cycled to clear error	Checked only at power up
046 SHORTED CIRCUIT TURNTABLE CW	Excessive load was detected when Turntable CW circuit was energized	Use a piece of wire to short the Turntable CW coil	This is a latched error. Power must be cycled to clear error	Checked only at power up
047 OPEN CIRCUIT TURNTABLE CCW	A load of less than 70mA was detected when Turntable CCW circuit was energized	Disconnect a wire from Turntable CCW coil	This is a latched error. Power must be cycled to clear error	Checked only at power up
048 SHORTED CIRCUIT TURNTABLE CCW	Excessive load was detected when Turntable CCW circuit was energized	Use a piece of wire to short the Turntable CCW coil	This is a latched error. Power must be cycled to clear error	Checked only at power up
049 OPEN CIRCUIT OUTRIGGER RETRACT	A load of less than 70mA was detected when Outrigger Retract circuit was energized	Disconnect a wire from Outrigger Retract coil	This is a latched error. Power must be cycled to clear error	Checked only at power up
050 SHORTED CIRCUIT OUTRIGGER RETRACT	Excessive load was detected when Outrigger Retract circuit was energized	Use a piece of wire to short the Outrigger Retract coil	This is a latched error. Power must be cycled to clear error	Checked only at power up
051 OPEN CIRCUIT OUTRIGGER EXTEND	A load of less than 70mA was detected when Outrigger Extend circuit was energized	Disconnect a wire from Outrigger Extend coil	This is a latched error. Power must be cycled to clear error	Checked only at power up
052 SHORTED CIRCUIT OUTRIGGER EXTEND	Excessive load was detected when Outrigger Extend circuit was energized	Use a piece of wire to short the Outrigger Extend coil	This is a latched error. Power must be cycled to clear error	Checked only at power up
053 OPEN CIRCUIT LF OUTRIGGER	A load of less than 70mA was detected when LF Outrigger circuit was energized	Disconnect a wire from LF Outrigger coil	This is a latched error. Power must be cycled to clear error	Checked only at power up
054 SHORTED CIRCUIT LF OUTRIGGER	Excessive load was detected when LF Outrigger circuit was energized	Use a piece of wire to short the LF Outrigger coil	This is a latched error. Power must be cycled to clear error	Checked only at power up
055 OPEN CIRCUIT RF OUTRIGGER	A load of less than 70mA was detected when RF Outrigger circuit was energized	Disconnect a wire from RF Outrigger coil	This is a latched error. Power must be cycled to clear error	Checked only at power up
056 SHORTED CIRCUIT RF OUTRIGGER	Excessive load was detected when RF Outrigger circuit was energized	Use a piece of wire to short the RF Outrigger coil	This is a latched error. Power must be cycled to clear error	Checked only at power up
057 OPEN CIRCUIT LR OUTRIGGER	A load of less than 70mA was detected when LR Outrigger circuit was energized	Disconnect a wire from LR Outrigger coil	This is a latched error. Power must be cycled to clear error	Checked only at power up
058 SHORTED CIRCUIT LR OUTRIGGER	Excessive load was detected when LR Outrigger circuit was energized	Use a piece of wire to short the LR Outrigger coil	This is a latched error. Power must be cycled to clear error	Checked only at power up

TABLE 3-3. ERROR CODE DEFINITIONS

ERROR MESSAGE	ERROR DEFINITION	TO SIMULATE ERROR	TO CLEAR ERROR	COMMENTS
059 OPEN CIRCUIT RR OUTRIGGER	A load of less than 70mA was detected when RR Outrigger circuit was energized	Disconnect a wire from RR Outrigger coil	This is a latched error. Power must be cycled to clear error	Checked only at power up
060 SHORTED CIRCUIT RR OUTRIGGER	Excessive load was detected when RR Outrigger circuit was energized	Use a piece of wire to short the RR Outrigger coil	This is a latched error. Power must be cycled to clear error	Checked only at power up
061 OPEN CIRCUIT ENGINE THROTTLE	A load of less than 70mA was detected when Engine Throttle circuit was energized	Disconnect a wire from Engine Throttle coil	This is a latched error. Power must be cycled to clear error	Error Suppressed due to low current draw
062 SHORTED CIRCUIT ENGINE THROTTLE	Excessive load was detected when Engine Throttle circuit was energized	Use a piece of wire to short the Engine Throttle coil	This is a latched error. Power must be cycled to clear error	Error Suppressed due to low current draw
063 OPEN CIRCUIT ENGINE STARTER	A load of less than 70mA was detected when Engine Starter circuit was energized	Disconnect a wire from Engine Starter coil	This is a latched error. Power must be cycled to clear error	Not Tested, Do not want to crank engine on power up
064 SHORTED CIRCUIT ENGINE STARTER	Excessive load was detected when Engine Starter circuit was energized	Use a piece of wire to short the Engine Starter coil	This is a latched error. Power must be cycled to clear error	Not Tested, Do not want to crank engine on power up
065 OPEN CIRCUIT ENGINE CHOKE	A load of less than 70mA was detected when Engine Choke circuit was energized	Disconnect a wire from Engine Choke coil	This is a latched error. Power must be cycled to clear error	Error Suppressed due to low current draw
066 SHORTED CIRCUIT ENGINE CHOKE	Excessive load was detected when Engine Choke circuit was energized	Use a piece of wire to short the Engine Choke coil	This is a latched error. Power must be cycled to clear error	Error Suppressed due to low current draw
067 OPEN CIRCUIT ENGINE STOP	A load of less than 70mA was detected when Engine Stop circuit was energized	Disconnect a wire from Engine Stop coil	This is a latched error. Power must be cycled to clear error	Error Suppressed due to low current draw
068 SHORTED CIRCUIT ENGINE STOP	Excessive load was detected when Engine Stop circuit was energized	Use a piece of wire to short the Engine Stop coil	This is a latched error. Power must be cycled to clear error	Error Suppressed due to low current draw
069 OPEN CIRCUIT PROPORTION-AL	A load of less than 70mA was detected when Proportional circuit was energized	Disconnect a wire from Proportional coil	This is a latched error. Power must be cycled to clear error	Checked only at power up
070 SHORTED CIRCUIT PROPORTIONAL	Excessive load was detected when Proportional circuit was energized	Use a piece of wire to short the Proportional coil	This is a latched error. Power must be cycled to clear error	Checked only at power up
071 OPEN CIRCUIT MOTOR CONTROL ENABLE	A load of less than 70mA was detected when Motor Control Enable circuit was energized	Disconnect a wire from Motor Control Enable coil		Error Suppressed due to low current draw
072 SHORTED CIRCUIT MOTOR CONTROL ENABLE	Excessive load was detected when Motor Control Enable circuit was energized	Use a piece of wire to short the Motor Control Enable coil		Error Suppressed due to low current draw
073 OPEN CIRCUIT SPARE OUTPUT	A load of less than 70mA was detected when Spare Output circuit was energized	Disconnect a wire from Spare Output coil	This is a latched error. Power must be cycled to clear error	Not Used

TABLE 3-3. ERROR CODE DEFINITIONS

ERROR MESSAGE	ERROR DEFINITION	TO SIMULATE ERROR	TO CLEAR ERROR	COMMENTS
074 SHORTED CIRCUIT SPARE OUTPUT	Excessive load was detected when Spare Output circuit was energized	Use a piece of wire to short the Spare Output coil	This is a latched error. Power must be cycled to clear error	Not Used
075 OPEN CIRCUIT AC SWITCH	A load of less than 70mA was detected when AC Switch circuit was energized	Disconnect a wire from AC Switch coil		Error Suppressed due to low current draw
076 SHORTED CIRCUIT AC SWITCH	Excessive load was detected when AC Switch circuit was energized	Use a piece of wire to short the AC Switch coil		Error Suppressed due to low current draw
077 OPEN CIRCUIT STROBE	A load of less than 70mA was detected when Strobe circuit was energized	Disconnect a wire from Strobe		Error Suppressed due to low current draw
078 SHORTED CIRCUIT STROBE	Excessive load was detected when Strobe circuit was energized	Use a piece of wire to short the Strobe coil		Error Suppressed due to low current draw
079 OPEN CIRCUIT DRIVE PWM	A load of less than 70mA was detected when Drive PWM circuit was energized	Disconnect a wire from Drive PWM coil	This is a latched error. Power must be cycled to clear error	Checked only at power up Machines with Drive option only
080 SHORTED CIRCUIT DRIVE PWM	Excessive load was detected when Drive PWM circuit was energized	Use a piece of wire to short the Drive PWM coil	This is a latched error. Power must be cycled to clear error	Checked only at power up Machines with Drive option only
081 OPEN CIRCUIT DRIVE ENABLE	A load of less than 70mA was detected when Drive Enable circuit was energized	Disconnect a wire from Drive Enable coil	This is a latched error. Power must be cycled to clear error	Checked only at power up Machines with Drive option only
082 SHORTED CIRCUIT DRIVE ENABLE	Excessive load was detected when Drive Enable circuit was energized	Use a piece of wire to short the Drive Enable coil	This is a latched error. Power must be cycled to clear error	Checked only at power up Machines with Drive option only
083 OPEN CIRCUIT DRIVE DUMP (C21)	A load of less than 70mA was detected when Drive Dump (C21) circuit was energized	Disconnect a wire from Drive Dump (C21) coil	This is a latched error. Power must be cycled to clear error	Checked only at power up Machines with 4WD option only
084 SHORTED CIRCUIT DRIVE DUMP (C21)	Excessive load was detected when Drive Dump (C21) circuit was energized	Use a piece of wire to short the Drive Engage coil	This is a latched error. Power must be cycled to clear error	Checked only at power up Machines with 4WD option only
085 OPEN CIRCUIT TURN LEFT (C22)	A load of less than 70mA was detected when Turn Left (C22) circuit was energized	Disconnect a wire from Turn Left (C22) coil	This is a latched error. Power must be cycled to clear error	Checked only at power up Machines with 4WD option only
086 SHORTED CIRCUIT TURN LEFT (C22)	Excessive load was detected when Turn Left (C22) circuit was energized	Use a piece of wire to short the Turn Left (C22) coil	This is a latched error. Power must be cycled to clear error	Checked only at power up Machines with 4WD option only
087 OPEN CIRCUIT TURN RIGHT (C23)	A load of less than 70mA was detected when Turn Right (C23) circuit was energized	Disconnect a wire from Turn Right (C23) coil	This is a latched error. Power must be cycled to clear error	Checked only at power up Machines with 4WD option only
088 SHORTED CIRCUIT TURN RIGHT (C23)	Excessive load was detected when Turn Right (C23) circuit was energized	Use a piece of wire to short the Turn Right (C23) coil	This is a latched error. Power must be cycled to clear error	Checked only at power up Machines with 4WD option only

TABLE 3-3. ERROR CODE DEFINITIONS

ERROR MESSAGE	ERROR DEFINITION	TO SIMULATE ERROR	TO CLEAR ERROR	COMMENTS
089 OPEN CIRCUIT FORWARD 1 (C24)	A load of less than 70mA was detected when Forward 1 (C24) circuit was energized	Disconnect a wire from Forward 1 (C24) coil	This is a latched error. Power must be cycled to clear error	Checked only at power up Machines with 4WD option only
090 SHORTED CIRCUIT FORWARD 1 (C24)	Excessive load was detected when Forward 1 (C24) circuit was energized	Use a piece of wire to short the Forward 1 (C24) coil	This is a latched error. Power must be cycled to clear error	Checked only at power up Machines with 4WD option only
091 OPEN CIRCUIT REVERSE 1 (C25)	A load of less than 70mA was detected when Reverse 1 (C25) circuit was energized	Disconnect a wire from Reverse 1 (C25) coil	This is a latched error. Power must be cycled to clear error	Checked only at power up Machines with 4WD option only
092 SHORTED CIRCUIT REVERSE 1 (C25)	Excessive load was detected when Reverse 1 (C25) circuit was energized	Use a piece of wire to short the Reverse 1 (C25) coil	This is a latched error. Power must be cycled to clear error	Checked only at power up Machines with 4WD option only
093 OPEN CIRCUIT FORWARD 2 (C27)	A load of less than 70mA was detected when Forward 2 (C27) circuit was energized	Disconnect a wire from Forward 2 (C27) coil	This is a latched error. Power must be cycled to clear error	Checked only at power up Machines with 4WD option only
094 SHORTED CIRCUIT FORWARD 2 (C27)	Excessive load was detected when Forward 2 (C27) circuit was energized	Use a piece of wire to short the Forward 2 (C27) coil	This is a latched error. Power must be cycled to clear error	Checked only at power up Machines with 4WD option only
095 OPEN CIRCUIT REVERSE 2 (C28)	A load of less than 70mA was detected when Reverse 2 (C28) circuit was energized	Disconnect a wire from Reverse 2 (C28) coil	This is a latched error. Power must be cycled to clear error	Checked only at power up Machines with 4WD option only
096 SHORTED CIRCUIT REVERSE 2 (C28)	Excessive load was detected when Reverse 2 (C28) circuit was energized	Use a piece of wire to short the Reverse 2 (C28) coil	This is a latched error. Power must be cycled to clear error	Checked only at power up Machines with 4WD option only
097 OPEN CIRCUIT TORQUE H/L (C29)	A load of less than 70mA was detected when Torque H/L (C29) circuit was energized	Disconnect a wire from Torque H/L (C29) coil	This is a latched error. Power must be cycled to clear error	Checked only at power up Machines with 4WD option only
098 SHORTED CIRCUIT TORQUE H/L (C29)	Excessive load was detected when Torque H/L (C29) circuit was energized	Use a piece of wire to short the Torque H/L (C29) coil	This is a latched error. Power must be cycled to clear error	Checked only at power up Machines with 4WD option only
099 OPEN CIRCUIT TORQUE H/L (C30)	A load of less than 70mA was detected when Torque H/L (C30) circuit was energized	Disconnect a wire from Torque H/L (C30) coil	This is a latched error. Power must be cycled to clear error	Checked only at power up Machines with 4WD option only
100 SHORTED CIRCUIT TORQUE H/L (C30)	Excessive load was detected when Torque H/L (C30) circuit was energized	Use a piece of wire to short the Torque H/L (C30) coil	This is a latched error. Power must be cycled to clear error	Checked only at power up Machines with 4WD option only
101 OPEN CIRCUIT TORQUE H/L (C31)	A load of less than 70mA was detected when Torque H/L (C31) circuit was energized	Disconnect a wire from Torque H/L (C31) coil	This is a latched error. Power must be cycled to clear error	Checked only at power up Machines with 4WD option only
102 SHORTED CIRCUIT TORQUE H/L (C31)	Excessive load was detected when Torque H/L (C31) circuit was energized	Use a piece of wire to short the Torque H/L (C31) coil	This is a latched error. Power must be cycled to clear error	Checked only at power up Machines with 4WD option only
103 OUTREACH NEAR MAXIMUM	Boom has exceeded 95% of maximum outreach	Put 500lbs in boom, level boom and extend until alarm sounds and error is displayed	This is a self clearing error. When error condition is corrected, error is cleared	Machines with Moment Sense option only

TABLE 3-3. ERROR CODE DEFINITIONS

ERROR MESSAGE	ERROR DEFINITION	TO SIMULATE ERROR	TO CLEAR ERROR	COMMENTS
104 OUTREACH AT MAXIMUM	Boom has reached maximum outreach setting	Put 500lbs in boom, level boom and extend until alarm sounds and error is displayed	This is a self clearing error. When error condition is corrected, error is cleared	Machines with Moment Sense option only
105 OVER MAXIMUM CYLINDER PRESSURE	Cylinder pressure has exceeded maximum pressure setting	Put 500lbs in boom, lower cylinder pressure setting using configuration program and extend boom until alarm sounds and error is displayed	This is a latched error. Power must be cycled to clear error	Machines with Moment Sense option only
106 OUTREACH SENSING ERROR	Cylinder safety pressure switch has detected maximum pressure setting	Disconnect safety pressure switch wires	This is a latched error. Power must be cycled to clear error	Machines with Moment Sense option only
107 ENGINE TEMP HIGH CHECK WATER LEVEL	Excessive engine temperature was detected	Remove wire from engine temperature sensor and connect wire to ground	This is a self clearing error. When error condition is corrected, error is cleared	Machines with 4WS option only
108 CHECK ALTERNATOR NOT CHARGING	Engine alternator is not charging	Remove P wire from alternator and connect wire to ground	This is a self clearing error. When error condition is corrected, error is cleared	Machines with 4WS option only
109 ENGINE RPM ERROR HIGH RPM IS TOO LOW	When driving, engine high RPM was too low	Misadjust engine high RPM to a value less than 3000 RPM and attempt to drive	This is a latched error. Power or engine must be cycled to clear error	Machines with 4WS option only
121 OPEN CIRCUIT BRAKE (FWS C21)	A load of less than 70mA was detected when Brake (FWS C21) circuit was energized	Disconnect a wire from Brake (FWS C21) coil	This is a latched error. Power must be cycled to clear error	Checked only at power up Machines with 4WS option only
122 SHORTED CIRCUIT BRAKE (FWS C21)	Excessive load was detected when Brake (FWS C21) circuit was energized	Use a piece of wire to short the Brake (FWS C21) coil	This is a latched error. Power must be cycled to clear error	Checked only at power up Machines with 4WS option only
123 OPEN CIRCUIT RS RET (FWS C22)	A load of less than 70mA was detected when RS Ret (FWS C22) circuit was energized	Disconnect a wire from RS Ret (FWS C22) coil	This is a latched error. Power must be cycled to clear error	Checked only at power up Machines with 4WS option only
124 SHORTED CIRCUIT RS RET (FWS C22)	Excessive load was detected when RS Ret (FWS C22) circuit was energized	Use a piece of wire to short the RS Ret (FWS C22) coil	This is a latched error. Power must be cycled to clear error	Checked only at power up Machines with 4WS option only
125 OPEN CIRCUIT RS EXT (FWS C23)	A load of less than 70mA was detected when RS Ext (FWS C23) circuit was energized	Disconnect a wire from RS Ext (FWS C23) coil	This is a latched error. Power must be cycled to clear error	Checked only at power up Machines with 4WS option only
126 SHORTED CIRCUIT RS EXT (FWS C23)	Excessive load was detected when RS Ext (FWS C23) circuit was energized	Use a piece of wire to short the RS Ext (FWS C23) coil	This is a latched error. Power must be cycled to clear error	Checked only at power up Machines with 4WS option only
127 OPEN CIRCUIT FS RET (FWS C24)	A load of less than 70mA was detected when FS Ret (FWS C24) circuit was energized	Disconnect a wire from FS Ret (FWS C24) coil	This is a latched error. Power must be cycled to clear error	Checked only at power up Machines with 4WS option only
128 SHORTED CIRCUIT FS RET (FWS C24)	Excessive load was detected when FS Ret (FWS C24) circuit was energized	Use a piece of wire to short the FS Ret (FWS C24) coil	This is a latched error. Power must be cycled to clear error	Checked only at power up Machines with 4WS option only

TABLE 3-3. ERROR CODE DEFINITIONS

ERROR MESSAGE	ERROR DEFINITION	TO SIMULATE ERROR	TO CLEAR ERROR	COMMENTS
129 OPEN CIRCUIT FS EXT (FWS C25)	A load of less than 70mA was detected when FS Ext (FWS C25) circuit was energized	Disconnect a wire from FS Ext (FWS C25) coil	This is a latched error. Power must be cycled to clear error	Checked only at power up Machines with 4WS option only
130 SHORTED CIRCUIT FS RET (FWS C25)	Excessive load was detected when FS Ext (FWS C25) circuit was energized	Use a piece of wire to short the FS Ext (FWS C25) coil	This is a latched error. Power must be cycled to clear error	Checked only at power up Machines with 4WS option only
131 OPEN CIRCUIT DC D FWD (FWS C26)	A load of less than 70mA was detected when DC D Fwd (FWS C26) circuit was energized	Disconnect a wire from DC D Fwd (FWS C26) coil	This is a latched error. Power must be cycled to clear error	Checked only at power up Machines with 4WS option only
132 SHORTED CIRCUIT DC D FWD (FWS C26)	Excessive load was detected when DC D Fwd (FWS C26) circuit was energized	Use a piece of wire to short the DC D Fwd (FWS C26) coil	This is a latched error. Power must be cycled to clear error	Checked only at power up Machines with 4WS option only
133 OPEN CIRCUIT DC D REV (FWS C27)	A load of less than 70mA was detected when DC D Rev (FWS C27) circuit was energized	Disconnect a wire from DC D Rev (FWS C27) coil	This is a latched error. Power must be cycled to clear error	Checked only at power up Machines with 4WS option only
134 SHORTED CIRCUIT DC D REV (FWS C27)	Excessive load was detected when DC D Rev (FWS C27) circuit was energized	Use a piece of wire to short the DC D Rev (FWS C27) coil	This is a latched error. Power must be cycled to clear error	Checked only at power up Machines with 4WS option only
135 OPEN CIRCUIT DC D (FWS C28)	A load of less than 70mA was detected when DC D (FWS C28) circuit was energized	Disconnect a wire from DC D (FWS C28) coil	This is a latched error. Power must be cycled to clear error	Checked only at power up Machines with 4WS option only
136 SHORTED CIRCUIT DC D (FWS C28)	Excessive load was detected when DC D (FWS C28) circuit was energized	Use a piece of wire to short the DC D (FWS C28) coil	This is a latched error. Power must be cycled to clear error	Checked only at power up Machines with 4WS option only
137 OPEN CIRCUIT DC D (FWS C29)	A load of less than 70mA was detected when DC D (FWS C29) circuit was energized	Disconnect a wire from DC D (FWS C29) coil	This is a latched error. Power must be cycled to clear error	Checked only at power up Machines with 4WS option only
138 SHORTED CIRCUIT DC D (FWS C29)	Excessive load was detected when DC D (FWS C29) circuit was energized	Use a piece of wire to short the DC D (FWS C29) coil	This is a latched error. Power must be cycled to clear error	Checked only at power up Machines with 4WS option only
139 OPEN CIRCUIT DC D (FWS C30)	A load of less than 70mA was detected when DC D (FWS C30) circuit was energized	Disconnect a wire from DC D (FWS C30) coil	This is a latched error. Power must be cycled to clear error	Checked only at power up Machines with 4WS option only
140 SHORTED CIRCUIT DC D (FWS C30)	Excessive load was detected when DC D (FWS C30) circuit was energized	Use a piece of wire to short the DC D (FWS C30) coil	This is a latched error. Power must be cycled to clear error	Checked only at power up Machines with 4WS option only
141 OPEN CIRCUIT DC D (FWS C31)	A load of less than 70mA was detected when DC D (FWS C31) circuit was energized	Disconnect a wire from DC D (FWS C31) coil	This is a latched error. Power must be cycled to clear error	Checked only at power up Machines with 4WS option only
142 SHORTED CIRCUIT DC D (FWS C31)	Excessive load was detected when DC D (FWS C31) circuit was energized	Use a piece of wire to short the DC D (FWS C31) coil	This is a latched error. Power must be cycled to clear error	Checked only at power up Machines with 4WS option only
143 OPEN CIRCUIT (FWS C32)	A load of less than 70mA was detected when (FWS C32) circuit was energized	Disconnect a wire from (FWS C32) coil	This is a latched error. Power must be cycled to clear error	Checked only at power up Machines with 4WS option only

TABLE 3-3. ERROR CODE DEFINITIONS

ERROR MESSAGE	ERROR DEFINITION	TO SIMULATE ERROR	TO CLEAR ERROR	COMMENTS
144 SHORTED CIRCUIT (FWS C32)	Excessive load was detected when (FWS C32) circuit was energized	Use a piece of wire to short the (FWS C32) coil	This is a latched error. Power must be cycled to clear error	Checked only at power up Machines with 4WS option only
145 OPEN CIRCUIT (FWS C33)	A load of less than 70mA was detected when (FWS C33) circuit was energized	Disconnect a wire from (FWS C33) coil	This is a latched error. Power must be cycled to clear error	Checked only at power up Machines with 4WS option only
146 SHORTED CIRCUIT (FWS C33)	Excessive load was detected when (FWS C33) circuit was energized	Use a piece of wire to short the (FWS C33) coil	This is a latched error. Power must be cycled to clear error	Checked only at power up Machines with 4WS option only
147 OPEN CIRCUIT (FWS C34)	A load of less than 70mA was detected when (FWS C34) circuit was energized	Disconnect a wire from (FWS C34) coil	This is a latched error. Power must be cycled to clear error	Checked only at power up Machines with 4WS option only
148 SHORTED CIRCUIT (FWS C34)	Excessive load was detected when (FWS C34) circuit was energized	Use a piece of wire to short the (FWS C34) coil	This is a latched error. Power must be cycled to clear error	Checked only at power up Machines with 4WS option only
149 OPEN CIRCUIT (FWS R2)	A load of less than 70mA was detected when (FWS R2) circuit was energized	Disconnect a wire from (FWS R2) coil	This is a latched error. Power must be cycled to clear error	Checked only at power up Machines with 4WS option only
150 SHORTED CIRCUIT (FWS R2)	Excessive load was detected when (FWS R2) circuit was energized	Use a piece of wire to short the (FWS R2) coil	This is a latched error. Power must be cycled to clear error	Checked only at power up Machines with 4WS option only
151 OPEN CIRCUIT (FWS GEN G1)	A load of less than 70mA was detected when (FWS Gen G1) circuit was energized	Disconnect a wire from (FWS Gen G1) coil	This is a latched error. Power must be cycled to clear error	Checked only at power up Machines with 4WS option only
152 SHORTED CIRCUIT (FWS GEN G1)	Excessive load was detected when (FWS Gen G1) circuit was energized	Use a piece of wire to short the (FWS Gen G1) coil	This is a latched error. Power must be cycled to clear error	Checked only at power up Machines with 4WS option only
153 OPEN CIRCUIT (FWS CON 24V)	A load of less than 70mA was detected when (FWS Con 24V) circuit was energized	Disconnect a wire from (FWS Con 24V) coil	This is a latched error. Power must be cycled to clear error	Checked only at power up Machines with 4WS option only
154 SHORTED CIRCUIT (FWS CON 24V)	Excessive load was detected when (FWS Con 24V) circuit was energized	Use a piece of wire to short the (FWS Con 24V) coil	This is a latched error. Power must be cycled to clear error	Checked only at power up Machines with 4WS option only
155 OPEN CIRCUIT (FWS SPARE 1)	A load of less than 70mA was detected when (FWS Spare 1) circuit was energized	Disconnect a wire from (FWS Spare 1) coil	This is a latched error. Power must be cycled to clear error	Checked only at power up Machines with 4WS option only
156 SHORTED CIRCUIT (FWS SPARE 1)	Excessive load was detected when (FWS Spare 1) circuit was energized	Use a piece of wire to short the (FWS Spare 1) coil	This is a latched error. Power must be cycled to clear error	Checked only at power up Machines with 4WS option only
157 OPEN CIRCUIT (FWS SPARE 2)	A load of less than 70mA was detected when (FWS Spare 2) circuit was energized	Disconnect a wire from (FWS Spare 2) coil	This is a latched error. Power must be cycled to clear error	Checked only at power up Machines with 4WS option only
158 SHORTED CIRCUIT (FWS SPARE 2)	Excessive load was detected when (FWS Spare 2) circuit was energized	Use a piece of wire to short the (FWS Spare 2) coil	This is a latched error. Power must be cycled to clear error	Checked only at power up Machines with 4WS option only

TABLE 3-3. ERROR CODE DEFINITIONS

ERROR MESSAGE	ERROR DEFINITION	TO SIMULATE ERROR	TO CLEAR ERROR	COMMENTS
159 OPEN CIRCUIT (FWS SPARE 3)	A load of less than 70mA was detected when (FWS Spare 3) circuit was energized	Disconnect a wire from (FWS Spare 3) coil	This is a latched error. Power must be cycled to clear error	Checked only at power up Machines with 4WS option only
160 SHORTED CIRCUIT (FWS SPARE 3)	Excessive load was detected when (FWS Spare 3) circuit was energized	Use a piece of wire to short the (FWS Spare 3) coil	This is a latched error. Power must be cycled to clear error	Checked only at power up Machines with 4WS option only
161 OPEN CIRCUIT (FWS PROP A1)	A load of less than 70mA was detected when (FWS Prop A1) circuit was energized	Disconnect a wire from (FWS Prop A1) coil	This is a latched error. Power must be cycled to clear error	Checked only at power up Machines with 4WS option only
162 SHORTED CIRCUIT (FWS PROP A1)	Excessive load was detected when (FWS Prop A1) circuit was energized	Use a piece of wire to short the (FWS Prop A1) coil	This is a latched error. Power must be cycled to clear error	Checked only at power up Machines with 4WS option only
163 OPEN CIRCUIT (FWS PROP A2)	A load of less than 70mA was detected when (FWS Prop A2) circuit was energized	Disconnect a wire from (FWS Prop A2) coil	This is a latched error. Power must be cycled to clear error	Checked only at power up Machines with 4WS option only
164 SHORTED CIRCUIT (FWS PROP A2)	Excessive load was detected when (FWS Prop A2) circuit was energized	Use a piece of wire to short the (FWS Prop A2) coil	This is a latched error. Power must be cycled to clear error	Checked only at power up Machines with 4WS option only
165 OPEN CIRCUIT (FWS PROP B1)	A load of less than 70mA was detected when (FWS Prop B1) circuit was energized	Disconnect a wire from (FWS Prop B1) coil	This is a latched error. Power must be cycled to clear error	Checked only at power up Machines with 4WS option only
166 SHORTED CIRCUIT (FWS PROP B1)	Excessive load was detected when (FWS Prop B1) circuit was energized	Use a piece of wire to short the (FWS Prop B1) coil	This is a latched error. Power must be cycled to clear error	Checked only at power up Machines with 4WS option only
167 OPEN CIRCUIT (FWS PROP B2)	A load of less than 70mA was detected when (FWS Prop B2) circuit was energized	Disconnect a wire from (FWS Prop B2) coil	This is a latched error. Power must be cycled to clear error	Checked only at power up Machines with 4WS option only
168 SHORTED CIRCUIT (FWS PROP B2)	Excessive load was detected when (FWS Prop B2) circuit was energized	Use a piece of wire to short the (FWS Prop B2) coil	This is a latched error. Power must be cycled to clear error	Checked only at power up Machines with 4WS option only

THIS PAGE INTENTIONALLY LEFT BLANK

ERROR CODE DEFINITIONS – MOTOR CONTROLLER

The Motor Controller, located under the left power (driver side) compartment cover (behind the lower control box), indicates the operational status of the controller. If an error condition is detected, the appropriate error code will be displayed by a flashing indicator light. Refer to Figure 3-7 at the end of the error codes for a visual of the controller. Refer to Table 3-4 to resolve the Error.

TABLE 3-4. MOTOR CONTROLLER ERROR CODE DEFINITIONS

FLASH ERROR	PRIORITY ID	ERROR	DESCRIPTION	SOLUTION
Steady ON, no flashing	1	None	System is operating normally.	None required.
1	11	Configuration Range Error	One or more controller personality settings are out of range.	Use Sevcon calibrator to enter correct settings from latest Personality Sheet.
1	12	CRC Error	The controller personality checksum is incorrect.	Use Sevcon calibrator to enter correct settings from latest Personality Sheet. Otherwise, replace motor controller.
2	5	Sequence Error	Enable line is active at power up.	Check enable line, B- wiring, and Molex connector.
2	6	Accelerator Error	Invalid accelerator personality setting.	Check speed input line, B- wiring, Molex connector, and 1000 ohm resistor.
3	17	MOSFET Short Circuit	MOSFET short circuit or controller miswire detected	Check for miswired B+, B-, or pump cables. Make sure pump terminals are not shorted to frame. If cables and pump are OK, then replace motor controller.
4	14	Line Contactor Welded	The line contactor is welded or otherwise shorted.	Check line contactor wiring. If wiring is OK, then replace line contactor.
4	15	Line Contactor did not Close	Line contactor did not close or is otherwise open circuit.	Check line contactor wiring and Molex connector. Measure the contactor coil resistance; it should be around 50 ohms. If contactor and wiring are OK, then replace motor controller.
5	16	Motor Open Circuit	Pump motor cable disconnected.	Check pump-motor and controller cables. Measure pump motor resistance it should be near zero ohms.
6	N/A	Not used in this application	N/A	N/A
7	7	Low Battery	Battery voltage is too low.	Recharge the batteries. Look for shorted battery cells. Make sure one or more batteries are not reversed.
7	8	High Battery	Battery voltage is too high.	Make sure battery charger is off. Check for poor or corroded battery connections.
7	10	High Battery with Line Contactor Open	High battery voltage was detected at power up before line contactor closed.	Make sure battery charger is off or that the battery is not overcharged.
8	1	Thermal Cutback	Maximum power available to motor has been reduced due to excessive heat sink temperature.	Remove power and allow controller to cool. If error repeatedly occurs, look for binding on the hydraulic cylinders or sticking valves. Otherwise, the pump motor may be failing.
8	3	Pump I ² T Current Limit Cutback	Maximum power available to pump motor has been reduced by the Current Limit Cutback function.	Recycle power. If error repeatedly occurs, look for binding on the hydraulic cylinders or sticking valves. Otherwise, the pump motor may be failing.
9	N/A	Not used in this application	N/A	N/A
10	N/A	Not used in this application	N/A	N/A

TABLE 3-4. MOTOR CONTROLLER ERROR CODE DEFINITIONS

FLASH ERROR	PRIORITY ID	ERROR	DESCRIPTION	SOLUTION
11	18	Auto Zero Out of Range	Internal pump current measurement circuit could not be calibrated.	Replace motor controller.
11	24	System Monitor	Illegal system condition sensed due to internal hardware error.	Replace motor controller.
Single flash, then off	19	MOSFETs Off	MOSFETs did not pulse when the internal failsafe circuit was enabled.	Check for reversed cables among B+, B-, and A terminals. If no miswire is found, replace motor controller.
Single flash, then off	20	MOSFETs On	MOSFETs pulsed while the internal failsafe circuit was disabled.	Check for reversed cables among B+, B-, and A terminals. If no miswire is found, replace motor controller.
Single flash, then off	22	Contactor Drive Off	Contactor output did not pulse with the internal failsafe circuit enabled.	Replace motor controller.
Single flash, then off	23	Contactor Drive On	Contactor output pulsed while the internal failsafe circuit was disabled.	Replace motor controller.



INDICATOR LIGHT

Figure 3-7. Motor Controller

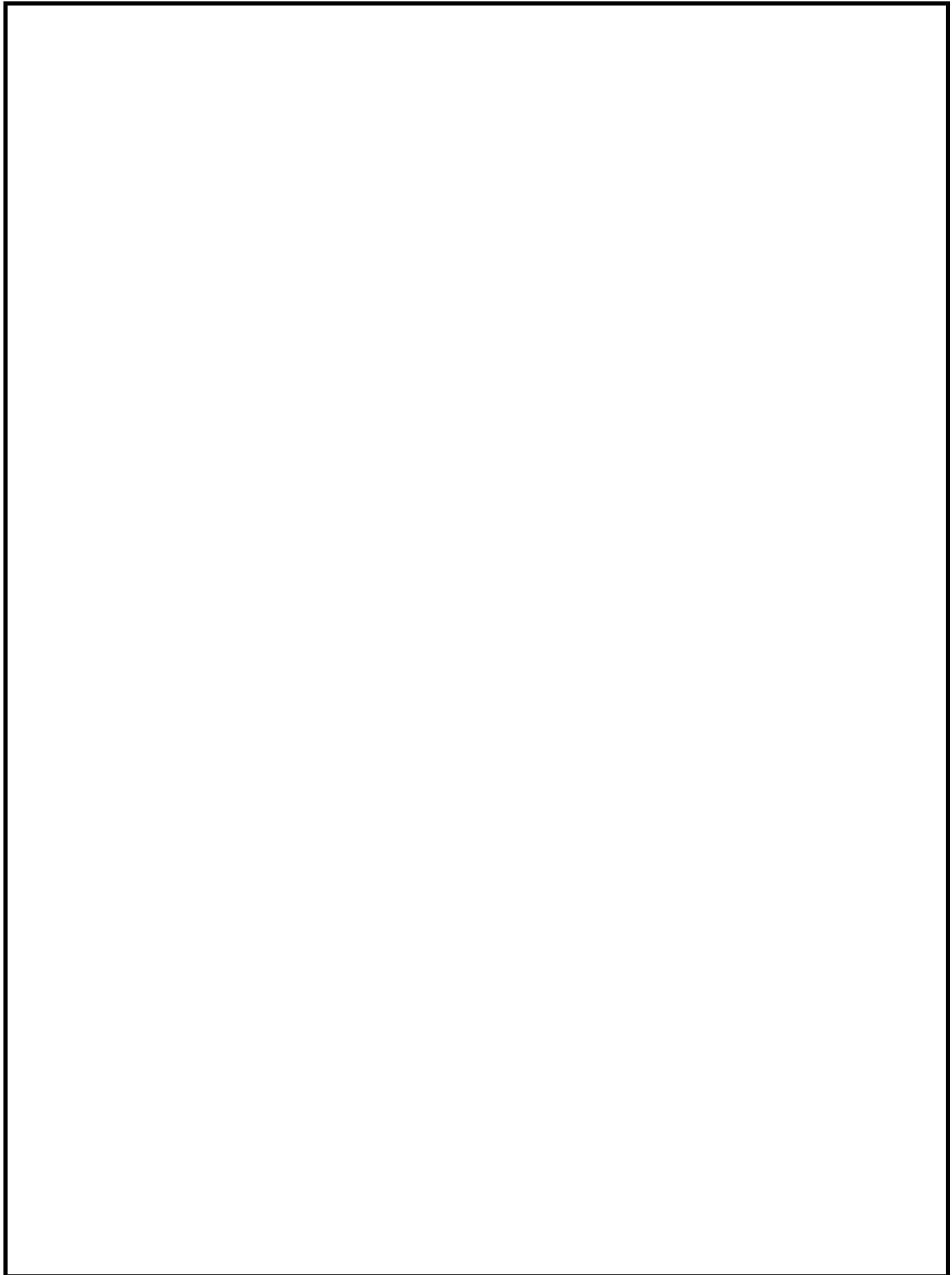

4 CYLINDER REPLACEMENT

If repair or replacement of an aerial work platform or outrigger hydraulic cylinder or its component parts becomes necessary, observe the following procedures in accordance with the safety precautions established in Section 1 of this manual.

Removing the hydraulic cylinder from the aerial work platform may require the use of specialized tools and lifting equipment. **NEVER** attempt to operate overhead hoists or cranes or related equipment without proper training, authorization and supervision. Perform all maintenance procedures only in an area that is well-lit and well-ventilated. Haulotte Group is not responsible for personal injury or property damage resulting from the improper use of equipment or failure to follow all procedures and related safety precautions.

Direct all questions regarding cylinder removal and replacement to your regional Haulotte Group representative or to the Haulotte Group Service Department at 1-(888) 440-9240.

LIFT CYLINDER REPLACEMENT

Use the following procedure to remove and replace faulty or damaged hydraulic cylinders on the aerial work platform.

WARNING

Repair and removal of the hydraulic cylinder requires the use of lifting straps and an overhead crane or lifting gear to support the aerial work platform and hydraulic cylinders. Personnel should be thoroughly trained in the operation of these devices before attempting installation or removal. Hydraulic cylinders are heavy and may have hydraulic oil on their surface. Failure to use proper equipment or to securely support aerial work platform and cylinders could result in death or serious injury and damage to aerial work platform.

- Start with the boom in the “stowed” position.
- Pull and hold the emergency lowering valve handle on the lift cylinder to relieve all hydraulic pressure to the cylinder. Refer to Figure 4-1.
- Turn key switch at the ground (lower) control panel, to the “OFF” position and remove the key.

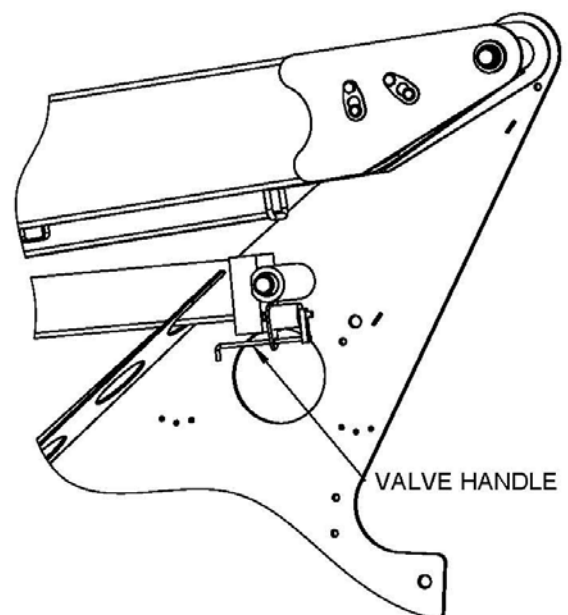

Figure 4-1. Location of Emergency Lowering Valve Handle

LIFT CYLINDER REPLACEMENT (CONTINUED)

- Locate the piston rod end of the cylinder to be removed. Unbolt and remove the pin retainer from each side of the pivot pin. Refer to Figure 4-2.
- Verify that the cylinder is supported by lifting straps and an overhead hoist or equivalent.
- Remove the pivot pin using a hammer and a brass or hardwood drift.
- Use an overhead crane or lifting gear to raise the boom section. Adequate clearance is necessary to reach the cylinder valve block (base end) and hydraulic hose ports.
- Unplug the appropriate emergency lowering valve solenoid.
- Tag and number all hydraulic hoses that attach to the cylinder valve block. Use a marker to label the valve block ports with the appropriate hose numbers.
- Place absorbent cloths below the cylinder ports and detach hydraulic hoses from the cylinder. Elevate hoses to prevent leakage. Plug or cap exposed hose fittings and cylinder ports.
- At the base of the cylinder, unbolt and remove retainer plate from each side of the pivot pin.
- Remove the pivot pin using a hammer and a brass or hardwood drift.
- Lift and remove the cylinder using an overhead hoist and lifting straps.
- Replace or reinstall the cylinder by following the above instructions in the reverse order of removal.
- Actuate the hydraulic system and check for leakage. Tighten hydraulic fittings as needed.
- Bleed trapped air from the hydraulic system by raising and lowering the telescoping boom with the reservoir fill port cap on, but not tightened. Allow several cycles of operation for trapped air to escape. Repeat as necessary.

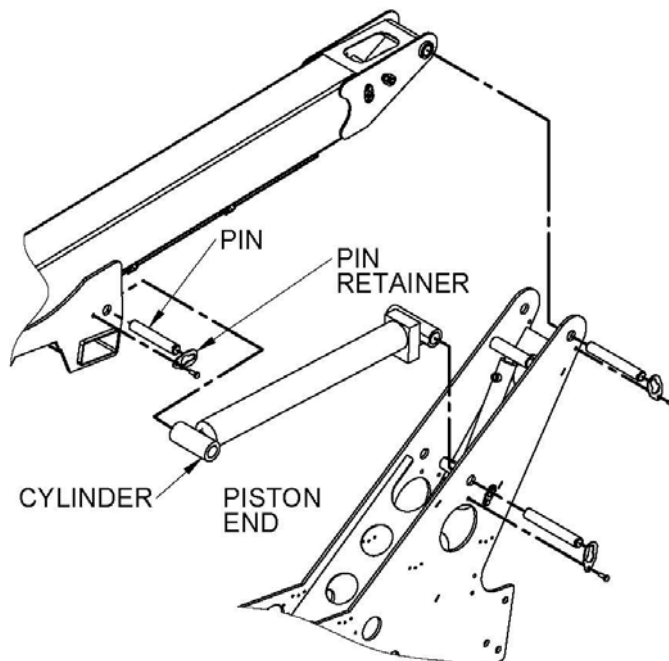

Figure 4-2. Lift Cylinder Replacement

OUTRIGGER CYLINDER REPLACEMENT

Use the following procedure to remove and replace faulty or damaged hydraulic cylinders on the outriggers:

- Lower the outrigger until the footpad is touching the ground. Do not transfer the weight of the aerial work platform onto the outrigger. Leave the weight of the aerial work platform on the trailer wheels.
- Remove the bolts securing the outrigger cylinder guard. Remove the cylinder guard. Refer to Figure 4-3.

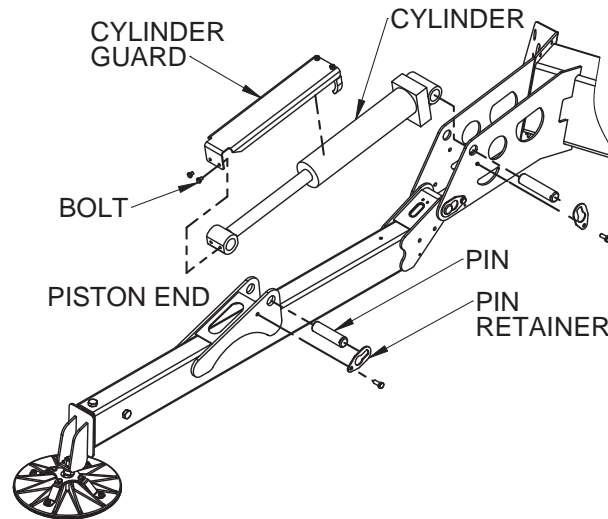

Figure 4-3. Outrigger Cylinder Replacement

- At the piston rod end of the cylinder, unbolt and remove the retainer plate from each side of the pivot pin.
- Place a block of wood shoring between the outrigger beam and cylinder.
- Remove the pivot pin using a hammer and a brass or hardwood drift.
- Fully retract the cylinder.
- Turn the key at the ground control station to the OFF position and remove the key.
- Tag and number all hydraulic hoses that attach to the cylinder valve block. Use a marker to label the valve block ports with the appropriate hose numbers.
- Unplug the cylinder valve solenoid. Refer to Figure 4-4.
- Place absorbent cloths below the cylinder ports and detach hydraulic hoses from the cylinder. Elevate hoses to prevent leakage. Plug or cap exposed hose fittings and cylinder ports.

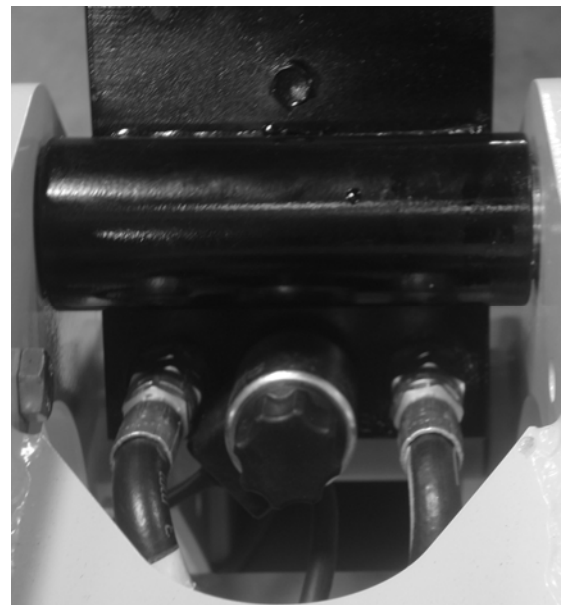

Figure 4-4. Cylinder Valve Removal

OUTRIGGER CYLINDER REPLACEMENT (CONTINUED)

- At the base of the cylinder, unbolt and remove retainer plate from each side of the pivot pin.
- Remove the pivot pin using a hammer and a brass or hardwood drift.
- Lift and remove the cylinder using an overhead hoist and lifting straps.
- Replace or reinstall the cylinder by following the above instructions in the reverse order of removal.
- Actuate the hydraulic system and check for leakage. Tighten hydraulic fittings as necessary.
- Bleed trapped air from the hydraulic system by raising and lowering the boom with the reservoir fill port cap on but not tightened. Allow several cycles of operation for trapped air to escape. Repeat as necessary.

5 DECAL REPLACEMENT



WARNING

Decals contain information that is required for the safe and proper use of the aerial work platform.

Decals should be considered necessary components of the machine and should be checked before each use to verify that they are correctly attached and legible.

Promptly replace all decals that are no longer legible.

DECAL REPLACEMENT - DECAL KIT

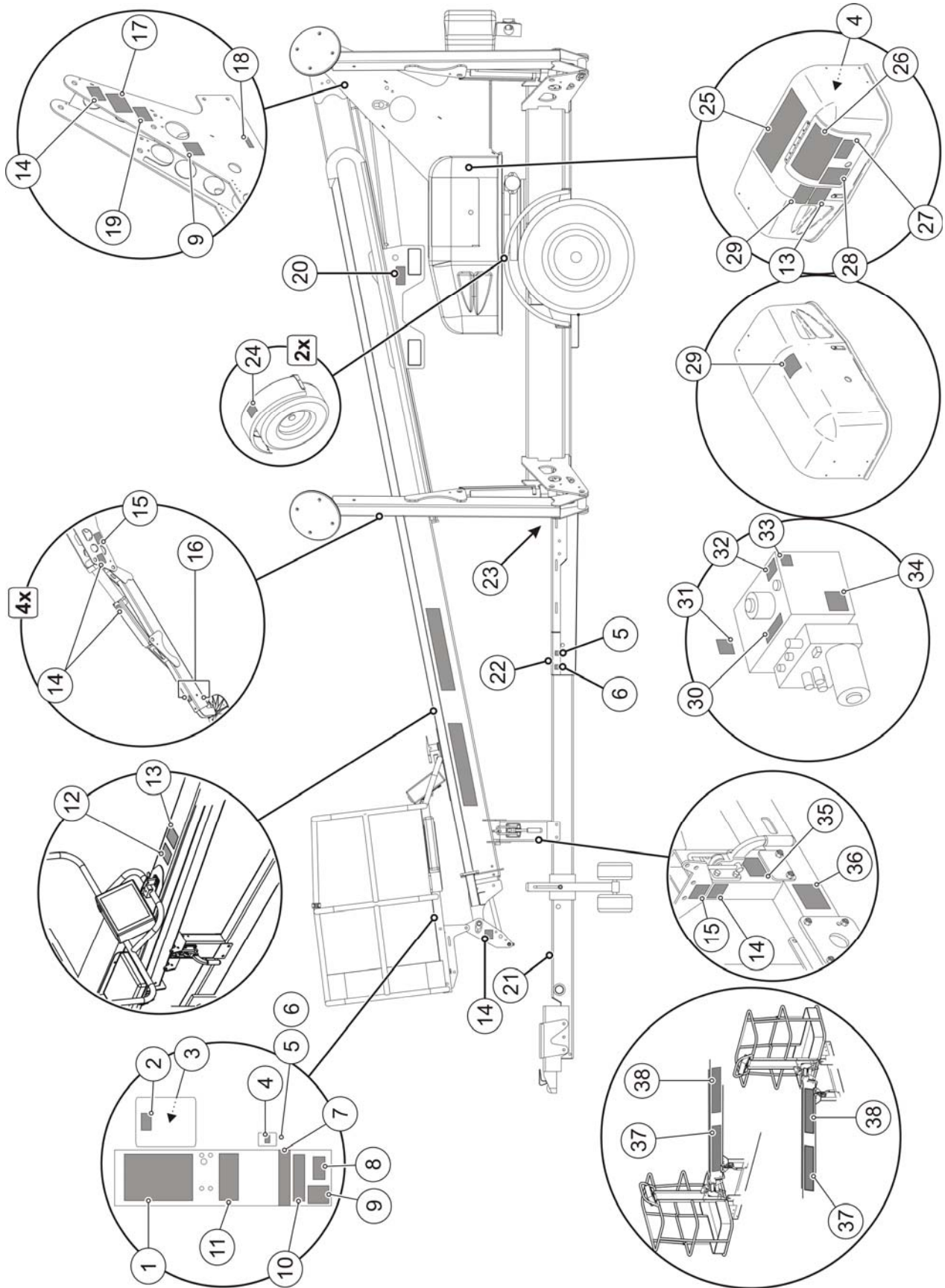

DECAL REPLACEMENT – DECAL KIT

B06-01-4002		DECAL KIT – Includes the following:	
ITEM NO.	PART NUMBER	DESCRIPTION	QTY.
1	B06-00-0471	Decal - Danger - Main Instruction / Hazard - Platform	1
2	B06-00-0475	Decal - Warning - Read / Understand Manual	1
3	B06-00-0473	Decal - Notice - Operator Manual Missing	1
4	B06-00-0062	Decal - Notice - AC Power	2
5	B06-00-0530	Decal - Air - 120 PSI	2
6	B06-00-0531	Decal - Water - 3000 PSI	2
7	B06-00-0552	Decal – Notice Lanyard Attachment	1
8	0202-0523	Decal - Flag, Made In USA	1
9	B06-00-0476	Decal - Notice - Range of Motion - 3632T / HTT 13	2
10	B06-00-0474	Decal - Notice - Platform Maximum Load	1
11	B06-00-0491	Decal - Warning - Platform Operation - 3632T / HTT 13	1
12	B06-00-0493	Decal - Caution - Latch / Jack / Brake	1
13	B06-00-0550	Decal - Warning - Unhitch To Operate	2
14	B06-00-0405	Decal - Warning - Hand Pinch Point	16
15	B06-00-0521	Decal - Danger - Tip Over Hazard	6
16	B06-00-0404	Decal - Warning - Outrigger Crush Foot	8
17	B06-00-0482	Decal - Danger - Electrocution	2
18	B06-00-0037	Decal - "Lubricate Semi - Annually"	1
19	B06-00-0506	Decal - Notice - Emergency Lower	2
20	B06-00-0477	Decal - Warning - Fork Lift Use	2
21	B06-00-0542	Decal - Warning - Maximum Tow Speed 65	1
22	B06-00-0496	Decal - Caution - Generator Plate Maximum 200	1
23	B06-00-0478	Decal - Notice - AC Power Connection	1
24	B06-00-0543	Decal - Warning - Crush Hazard	2
25	B06-00-0505	Decal - Danger - Main Instruction / Hazard - Base	1
26	B06-00-0468	Decal - Warning - Ground Operating	2
27	B06-00-0484	Decal - Danger - Battery / Charger Instruction	1
28	B06-00-0034	Decal - Danger - Battery / Charger Safety	1
29	B06-00-0495	Decal - Caution - Compartment Access	2
30	B06-00-0504	Decal - Notice - Emergency Hand Pump	1
31	B06-00-0503	Decal - Notice - Handle Applications	1
32	B06-00-0068	Decal - Notice - Low Foam Hyd Oil	1
33	B06-00-0494	Decal - Notice - Contains Hazardous Material	1
34	B06-00-0541	Decal - Caution - Manual Rotate / Retract	1
35	B06-00-0481	Decal - Caution - Transport Latch	1
36	B06-00-0544	Decal - Warning - Tow Hazard 65 mph	2
37	B06-00-0161B	Decal - 'Haulotte BilJax' - 5in Black / Red on Clear	2
38	B06-00-0480	Decal - 3632T / HTT 13 -Black Clear Vinyl with Black Letters	2

DECAL REPLACEMENT – IDENTIFICATION PLATES & OPTIONAL EQUIPMENT

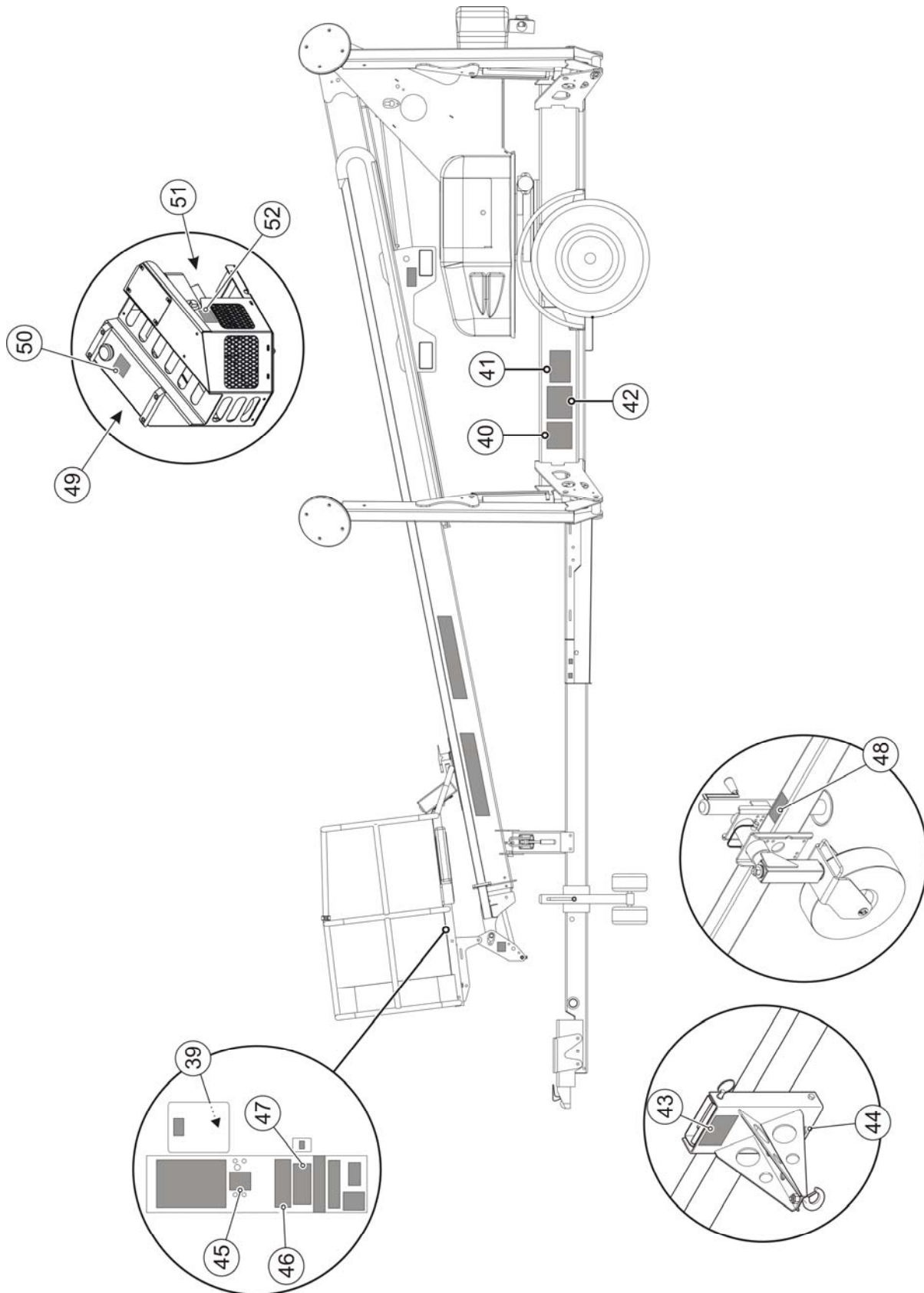

DECAL REPLACEMENT – IDENTIFICATION PLATES & OPTIONAL EQUIPMENT**IDENTIFICATION PLATES****IDENTIFICATION PLATES (Used on all standard equipment)**

ITEM NO.	PART NUMBER	DESCRIPTION	QTY.
39	B06-00-0526	Key Ring Tag	1
40	B06-00-0524	Annual Inspection Plate	1
41	B06-00-0490	VIN Plate	1
42	B06-00-0499	ANSI ID Plate	1

REPLACEMENT DECALS FOR OPTIONAL EQUIPMENT**DECAL REPLACEMENT FOR OPTIONAL EQUIPMENT**

ITEM NO.	PART NUMBER	DESCRIPTION	QTY.
43	B06-00-0485	Decal - Notice - Material Lift Set - up (Material Lift Option)	1
44	B06-00-0497	Decal - Notice - Material Lift Max 500 (Material Lift Option)	1
45	B06-00-0529	Decal - Notice - Platform Rotate (Manual Rotation Option)	1
46	B06-00-0527	Decal - Warning - Drive and Set (Drive and Set Option)	1
47	B06-00-0528	Decal - Notice - Drive and Set (Drive and Set Option)	1
48	B06-00-0553	Decal - Warning - Jockey Wheel (Drive and Set Option)	1
49	B06-00-0488	Decal - Caution - Component Damage (Gas Engine Option)	1
50	B06-00-0487	Decal - Notice - Unleaded Fuel Only (Gas Engine Option)	1
51	B06-00-0486	Decal - notice - engine Specifics (Gas Engine Option)	1
52	B06-00-0547	Decal - Warning - Eng Operate - Hot (Gas Engine Option)	1

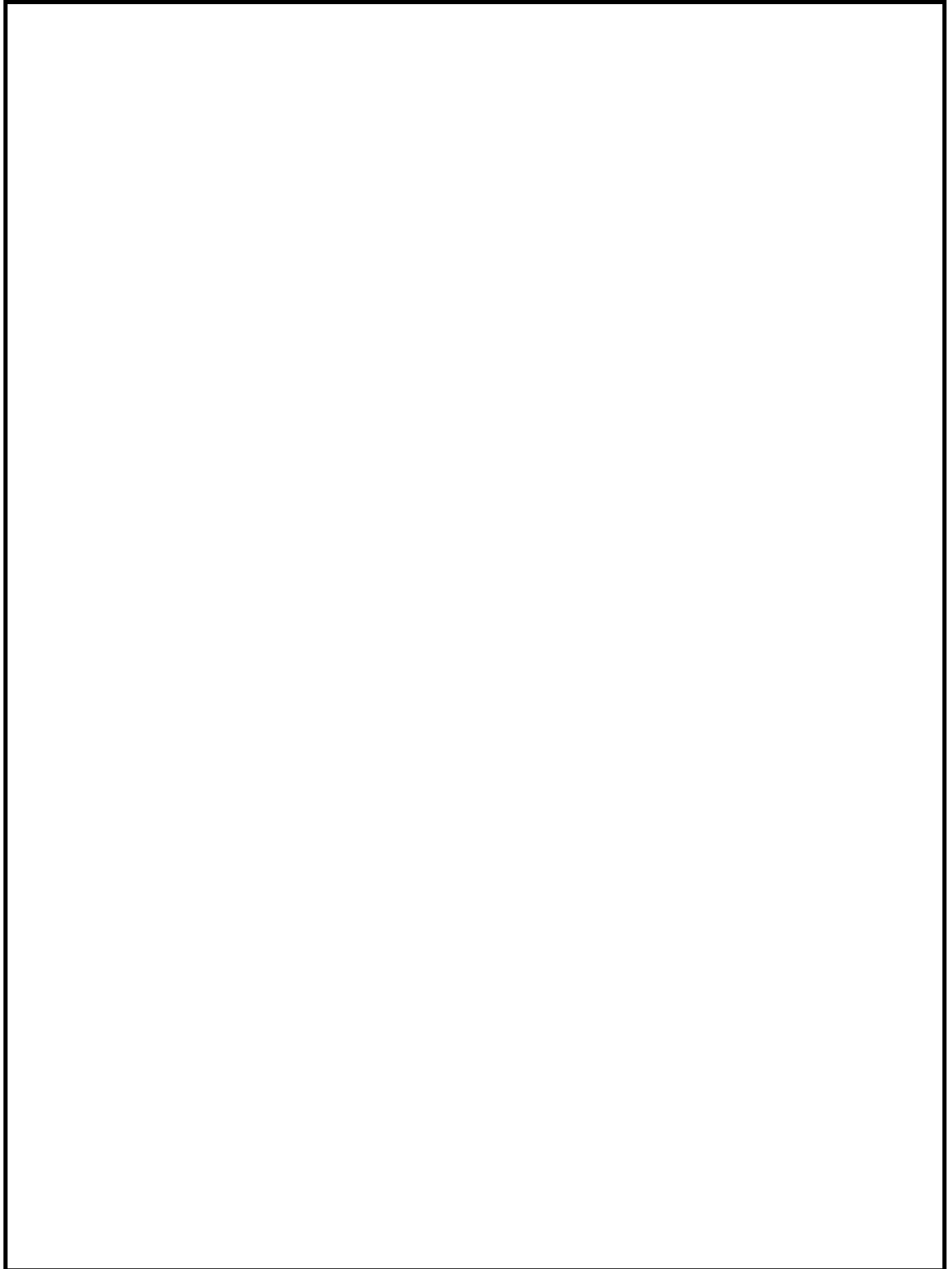

6 REPLACEMENT PARTS

TONGUE ASSEMBLY	60
TONGUE ASSEMBLY FOR DRIVE & SET OPTION	62
TONGUE ASSEMBLY FOR ELECTRIC BRAKE OPTION	64
DOLLY WHEEL ASSEMBLY	66
DOLLY WHEEL ASSEMBLY FOR DRIVE & SET OPTION	68
DOLLY WHEEL WITH TAPERED SWIVEL & YOKE ASSEMBLY (OPTION)	70
BOOM REST SWITCH ASSEMBLY	72
OUTRIGGER LEG ASSEMBLY	74
OUTRIGGER FOOT ASSEMBLY	76
BRAKE AND AXLE ASSEMBLY	78
BRAKE AND AXLE ASSEMBLY FOR DRIVE & SET OPTION	80
DRIVE MOTOR ASSEMBLY FOR DRIVE & SET OPTION	82
SLEW RING ASSEMBLY	84
BATTERY COMPARTMENT ASSEMBLY	86
CONTROL COMPARTMENT ASSEMBLY	88
CONTROL COMPARTMENT ASSEMBLY FOR DRIVE & SET OPTION	92
GROUND (LOWER) CONTROL BOX	94
POWER UNIT COMPARTMENT ASSEMBLY	96
POWER UNIT COMPONENTS	98
COVER ASSEMBLY	102
COUNTER WEIGHT ASSEMBLY	104
BOOM ASSEMBLY	106
PLATFORM MOUNT ASSEMBLY	112
AC POWER HOOK-UP ASSEMBLY	116
PLATFORM ASSEMBLY	118
PLATFORM (UPPER) CONTROL BOX	120

Use only parts manufactured and/or authorized by Haulotte Group when replacing damaged components. See the back pages for replacement part ordering information.

NOTE: Unless otherwise noted: High-strength Grade 5/Class 8.8 fasteners are used in the assembly of this equipment.

TONGUE ASSEMBLY

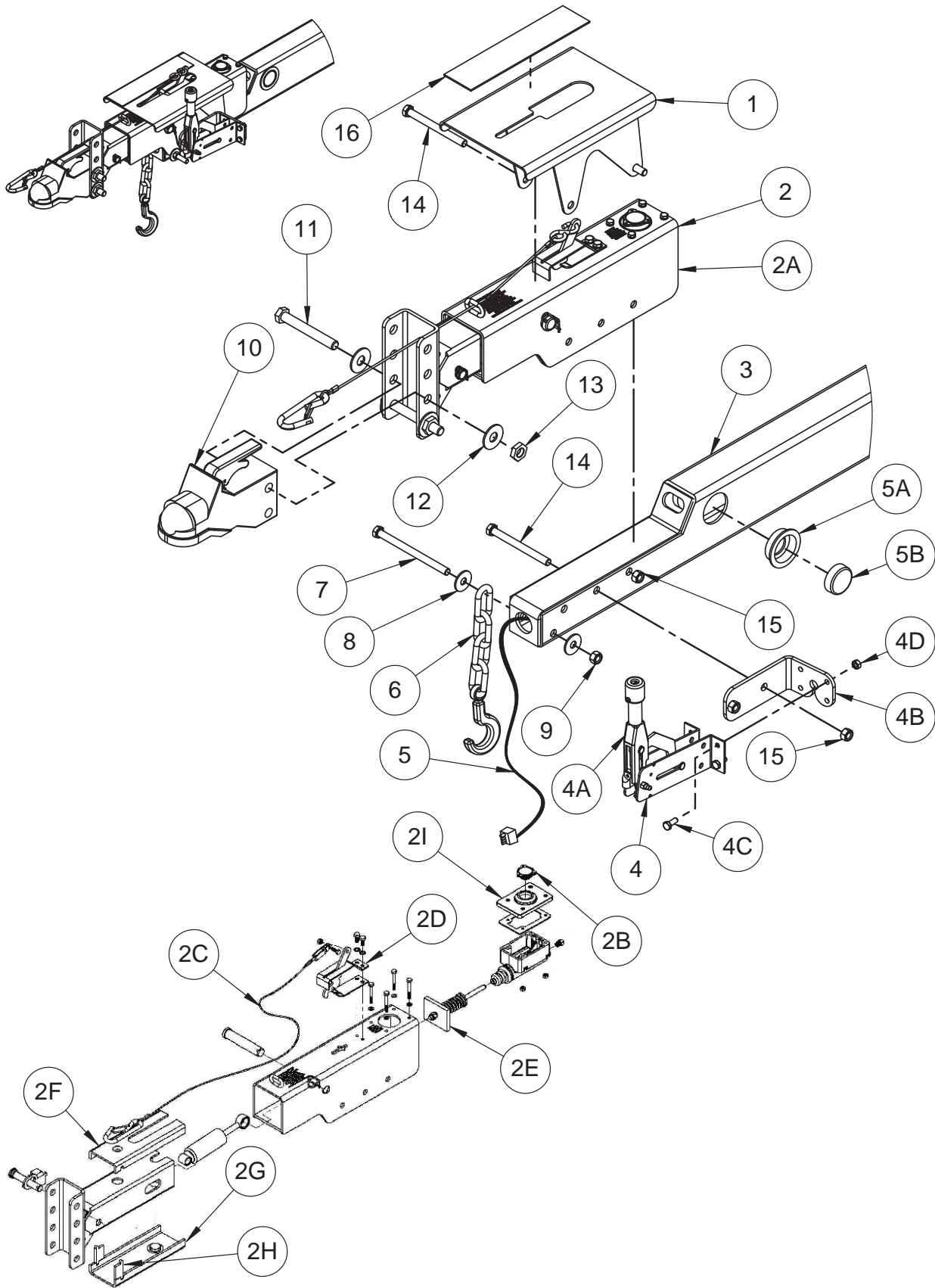

TONGUE ASSEMBLY			
ITEM NO.	PART NUMBER	DESCRIPTION	QTY.
1	A-00172	Hitch Step Revised for Compatibility Effective 2007	1
2	B12-00-0211	Coupler, Hydraulic Surge Assembly Replaces B12-00-0169 Effective 2008	1
2A	B12-00-0218	Master Cylinder (Excludes Cap)	1
2B	B12-00-0219	Cylinder Fill Cap	1
2C	B12-00-0220	Safety Cable	1
2D	B12-00-0221	Safety Lever	1
2E	B12-00-0222	Push Rod Assembly	1
2F	B12-00-0223	Chanel Slide, Top	1
2G	B12-00-0224	Chanel Slide, Bottom	1
2H	B12-00-0225	Channel Spacer	2
2I	B12-00-0220	Cap for Master Cylinder	1
3	A-00170	Tongue Tube	1
4	B22-00-0074	Hand Brake Assembly	1
4A	A-00192	Brake Lever Replaces A-00167 Effective 2006	1
4B	A-02177	Brake Bracket	1
4C	0096-0010	Screw, Hex Head Cap - M8 x 20	4
4D	0096-0040	Hex Nut with Nylon Insert, M8	4
4E	B04-06-0033	Flat Washer - Not Shown	1
4F	B36-00-0088	Pin, Clevis - Not Shown	1
4G	0090-0144	Pin, Cotter - 3/32 x 3/4 - Not Shown Replaced B36-00-0089 Effective 2006	4
5	A-00198	Tail Light Kit	1
5A	B01-10-0239	Grommet, Marker Light	2
5B	B01-10-0297	Marker Light, Red	2
6	B03-00-0017	Safety Chain Assembly	2
7	0096-0186	Screw, Hex Head Cap - M12 x 160	1
8	0096-0076	Flat Washer, M12	2
9	0096-0042	Hex Nut with Nylon Insert, M12	1
10	B12-00-0066 B12-00-0068	2in Ball Coupler 2 5/16in Ball Coupler (Option) - Not Shown	1
11	0090-0878	Screw, Hex Head Cap - 5/8 -11 X 4 3/4	2
12	0090-0425	Flat Washer, SAE - 5/8	4
13	0090-0194	Hex Nut with Nylon Insert, 5/8-11	2
14	0096-0026	Screw, Hex Head Cap - M12 x 130	3
15	0096-0042	Hex Nut with Nylon Insert, M12	3
16	A-00185	Tape, Non-Skid -7 x 5 3/4	1

TONGUE ASSEMBLY FOR DRIVE & SET OPTION

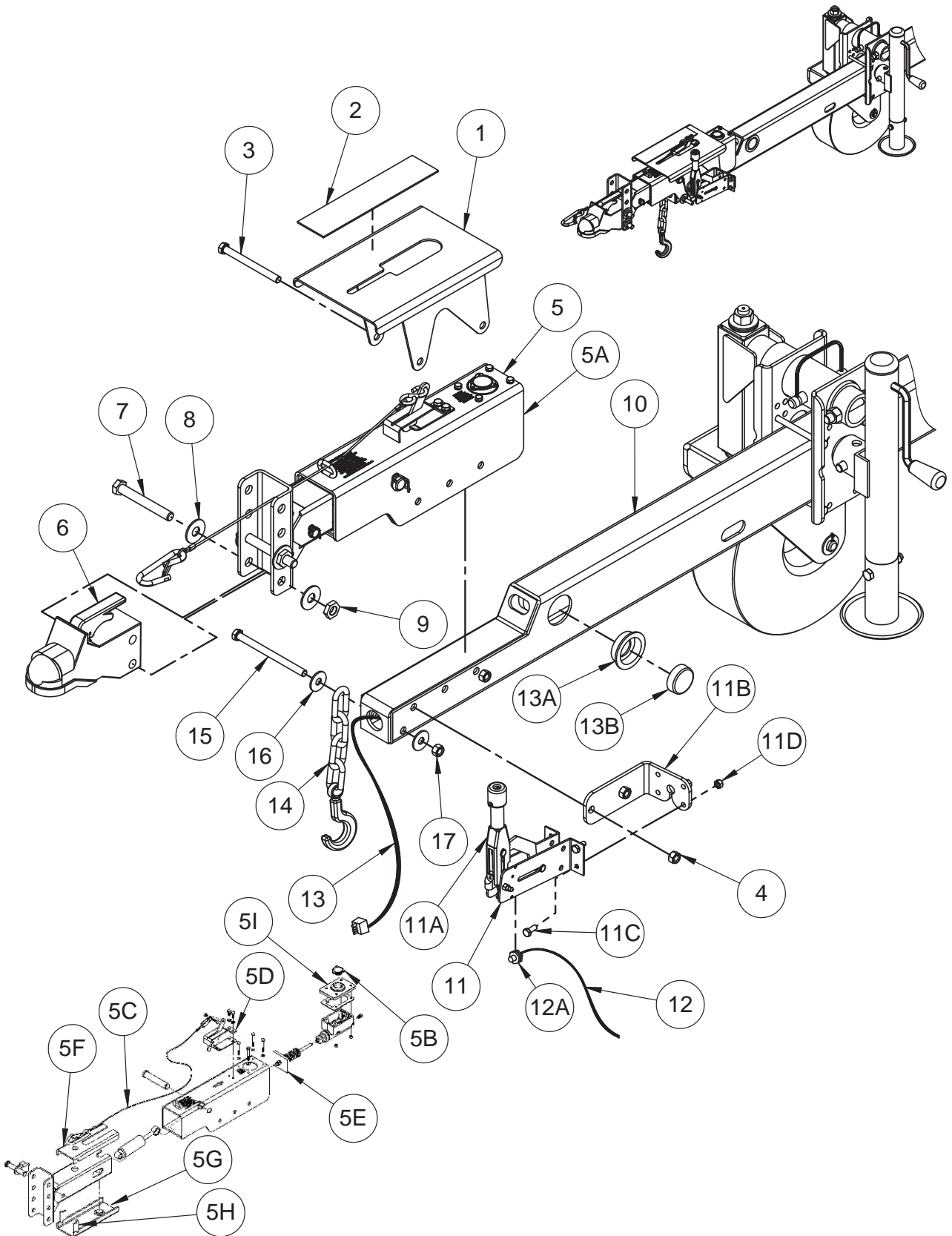

TONGUE ASSEMBLY FOR DRIVE & SET OPTION

ITEM NO.	PART NUMBER	DESCRIPTION	QTY.
1	A-00172	Hitch Step - Revised for Compatibility Effective 2007	1
2	A-00185	Tape, Non-Skid -7 x 5 3/4	1
3	0096-0026	Screw, Hex Head Cap - M12 x 130	3
4	0096-0042	Hex Nut with Nylon Insert, M12	3
5	B12-00-0211	Coupler, Hydraulic Surge Assembly Replaces B12-00-0169 Effective 2008	Ref
5A	B12-00-0218	Master Cylinder (Excludes Cap)	1
5B	B12-00-0219	Cylinder Fill Cap	1
5C	B12-00-0220	Safety Cable	1
5D	B12-00-0221	Safety Lever	1
5E	B12-00-0222	Push Rod Assembly	1
5F	B12-00-0223	Chanel Slide, Top	1
5G	B12-00-0224	Chanel Slide, Bottom	1
5H	B12-00-0225	Channel Spacer	2
5I	B12-00-0220	Cap for Master Cylinder	1
6	B12-00-0066 B12-00-0068	2in Ball Coupler 2 5/16in Ball Coupler (Option) - Not Shown	1
7	0090-0878	Screw, Hex Head Cap - 5/8 -11 X 4 3/4	2
8	0090-0425	Flat Washer, SAE - 5/8	4
9	0090-0194	Hex Nut with Nylon Insert, 5/8-11	2
10	A-00170	Tongue Tube	1
11	B22-00-0074	Hand Brake Assembly	1
11A	A-00192	Brake Lever Replaces A-00167 Effective 2006	1
11B	A-02177	Brake Bracket	1
11C	0096-0010	Screw, Hex Head Cap - M8 x 20	4
11D	0096-0040	Hex Nut with Nylon Insert, M8	4
11E	B04-06-0033	Flat Washer - Not Shown	1
11F	B36-00-0088	Pin, Clevis - Not Shown	1
11G	0090-0144	Pin, Cotter - 3/32 x 3/4 - Not Shown Replaced B36-00-0089 Effective 2006	4
12	A-00942	Brake Switch Assembly	1
12A	B01-03-0077	Switch, Brake NO & NC	1
12B	B01-09-0093	Seal, Wire - 16/18 Gauge - Green - Not Shown	2
12C	B01-09-0091	Terminal, Female - 16/18 Gage - Not Shown	2
12D	B01-09-0092	Connector Assembly - 2 Female - Not Shown	1
12E	B00-00-0170	Wire Casing - Not Shown	1
13	A-00198	Tail Light Kit	1
13A	B01-10-0239	Grommet, Marker Light	2
13B	B01-10-0297	Marker Light, Red	2
14	B03-00-0017	Safety Chain Assembly	2
15	0096-0186	Screw, Hex Head Cap - M12 x 160	1
16	0096-0076	Flat Washer, M12	2
17	0096-0042	Hex Nut with Nylon Insert, M12	1

TONGUE ASSEMBLY FOR ELECTRIC BRAKE OPTION

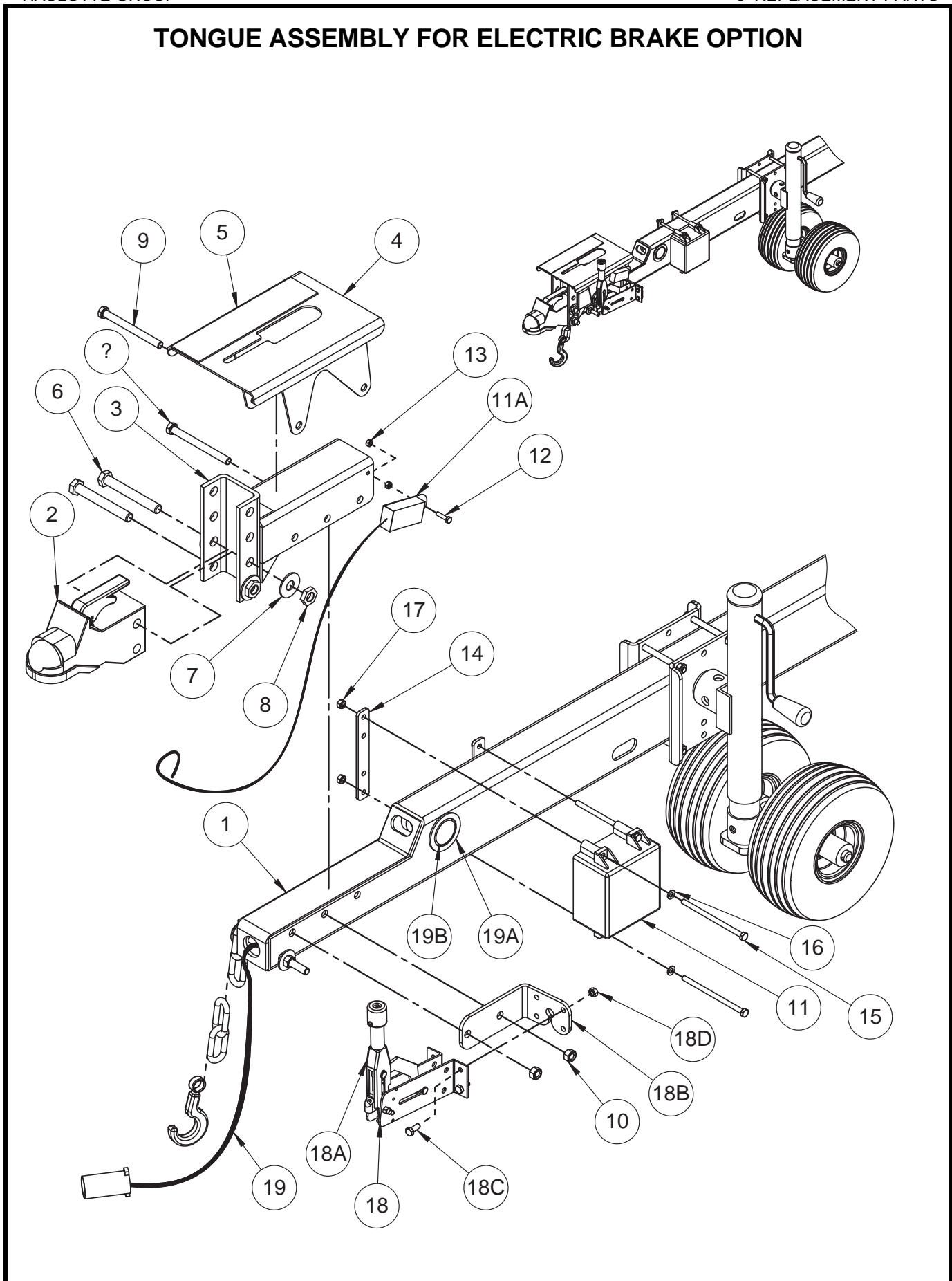

TONGUE ASSEMBLY FOR ELECTRIC BRAKE OPTION

ITEM NO.	PART NUMBER	DESCRIPTION	QTY.
1	A-00170	Tongue Tube	Ref.
2	B12-00-0066 B12-00-0068	2in Ball Coupler 2 5/16in Ball Coupler (Option) - Not Shown	1
3	A-00196	Electric Brake Coupler	1
4	A-00172	Hitch Step Revised for Compatibility - Effective 2007	1
5	A-00185	Tape, Non-Skid -7 x 5 3/4	1
6	0090-0878	Screw, Hex Head Cap - 5/8 -11 X 4 3/4	2
7	0090-0425	Flat Washer, SAE - 5/8	4
8	0090-0194	Hex Nut with Nylon Insert, 5/8-11	2
9	0096-0026	Screw, Hex Head Cap - M12 x 130	3
10	0096-0042	Hex Nut with Nylon Insert, M12	3
11	B01-10-0163	5 Amp Battery and Battery Charger	1
11A	B01-02-0062	Brake-Away Switch	1
12	0096-0004	Screw, Hex Head Cap - M6 x 25	1
13	0096-0039	Hex Nut with Nylon Insert, M6	2
14	B07-06-5865	Strap, Mount - Break Away	2
15	0096-0103	Screw, Hex Head Cap - M8 x 140	4
16	0096-0104	Flat Washer, M8	4
17	0096-0040	Hex Nut with Nylon Insert, M8	4
18	B22-00-0074	Hand Brake Assembly	1
18A	A-00192	Brake Lever Replaces A-00167 Effective 2006	1
18B	A-02177	Brake Bracket	1
18C	0096-0010	Screw, Hex Head Cap - M8 x 20	4
18D	0096-0040	Hex Nut with Nylon Insert, M8	4
18E	B04-06-0033	Flat Washer - Not Shown	1
18F	B36-00-0088	Pin, Clevis - Not Shown	1
18G	0090-0144	Pin, Cotter - 3/32 x 3/4 - Not Shown	4
19	A-00782	Wire Harness,700ft with Electric Brake	1
19A	B01-10-0239	Grommet, Marker Light	2
19B	B01-10-0297	Marker Light, Red	2
20	B03-00-0017	Safety Chain Assembly	2
21	B01-09-0104	Butt Splice (Heat Shrink) - Not Shown	3

DOLLY WHEEL ASSEMBLY

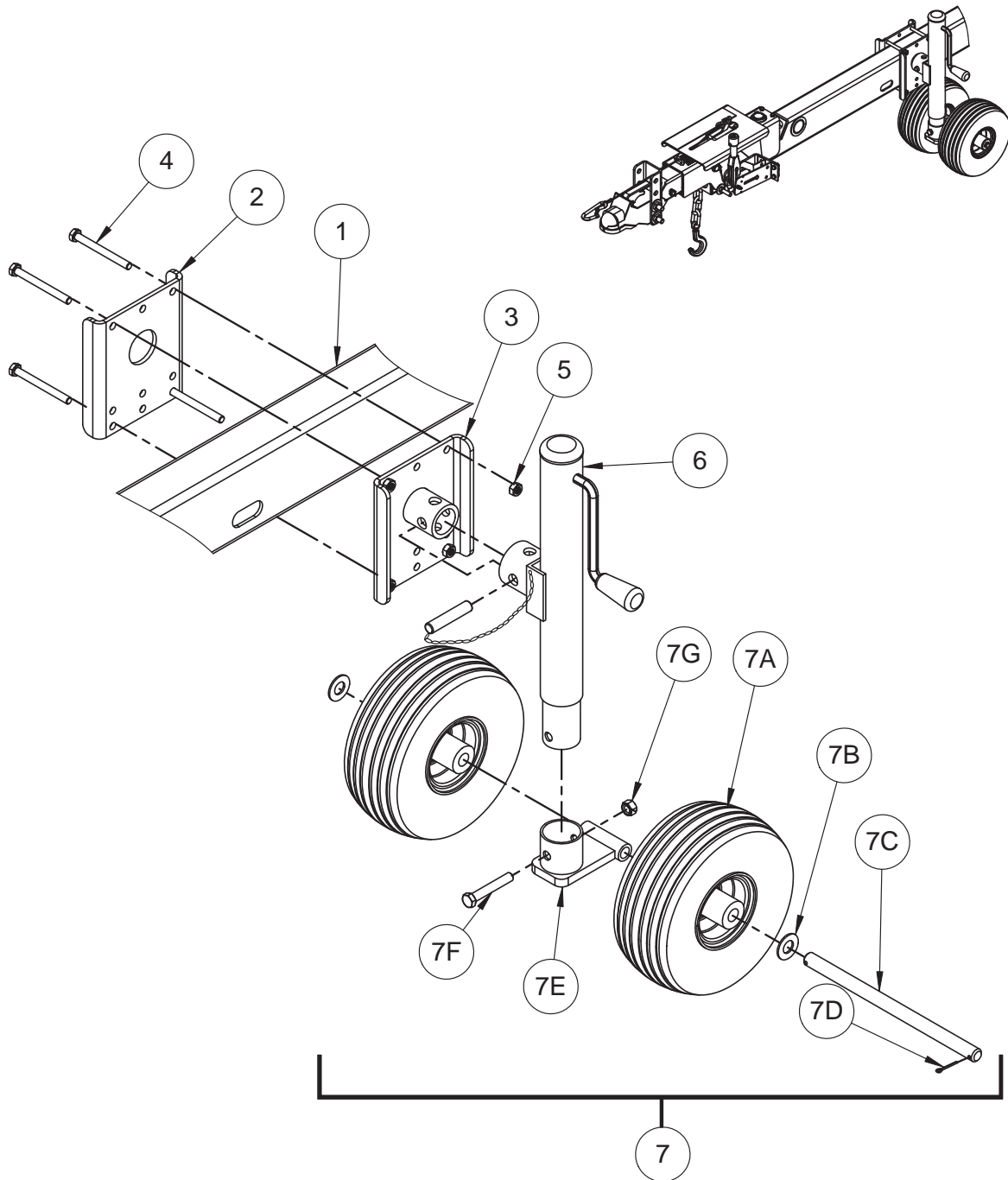

DOLLY WHEEL ASSEMBLY

ITEM NO.	PART NUMBER	DESCRIPTION	QTY.
1	A-00170	Tongue Tube	1
2	A-02166	Attach Plate	1
3	A-02167	Mount Assembly	1
4	0096-0105	Screw, Hex Head Cap - M10 x 100 Replaces 0096-0075 Effective 2006	4
5	0096-0041	Hex Nut with Nylon Insert, M10	4
6	A-02169	Jack Assembly Replaces A-00144 Effective 2006	1
7	A-02160-K	Tire and Wheel Assembly	1
7A	A-02165	Tire and Wheel Only	2
7B	0096-0087	Flat Washer, M20	2
7C	A-02164	Axle	1
7D	0090-0147	Pin, Cotter - 1/8 x 1 1/4	2
7E	A-02160	Jack Wheel Weldment	1
7F	0096-0022	Screw, Hex Head Cap - M12 x 75	1
7G	0096-0042	Hex Nut with Nylon Insert, M12	1

DOLLY WHEEL ASSEMBLY FOR DRIVE & SET OPTION

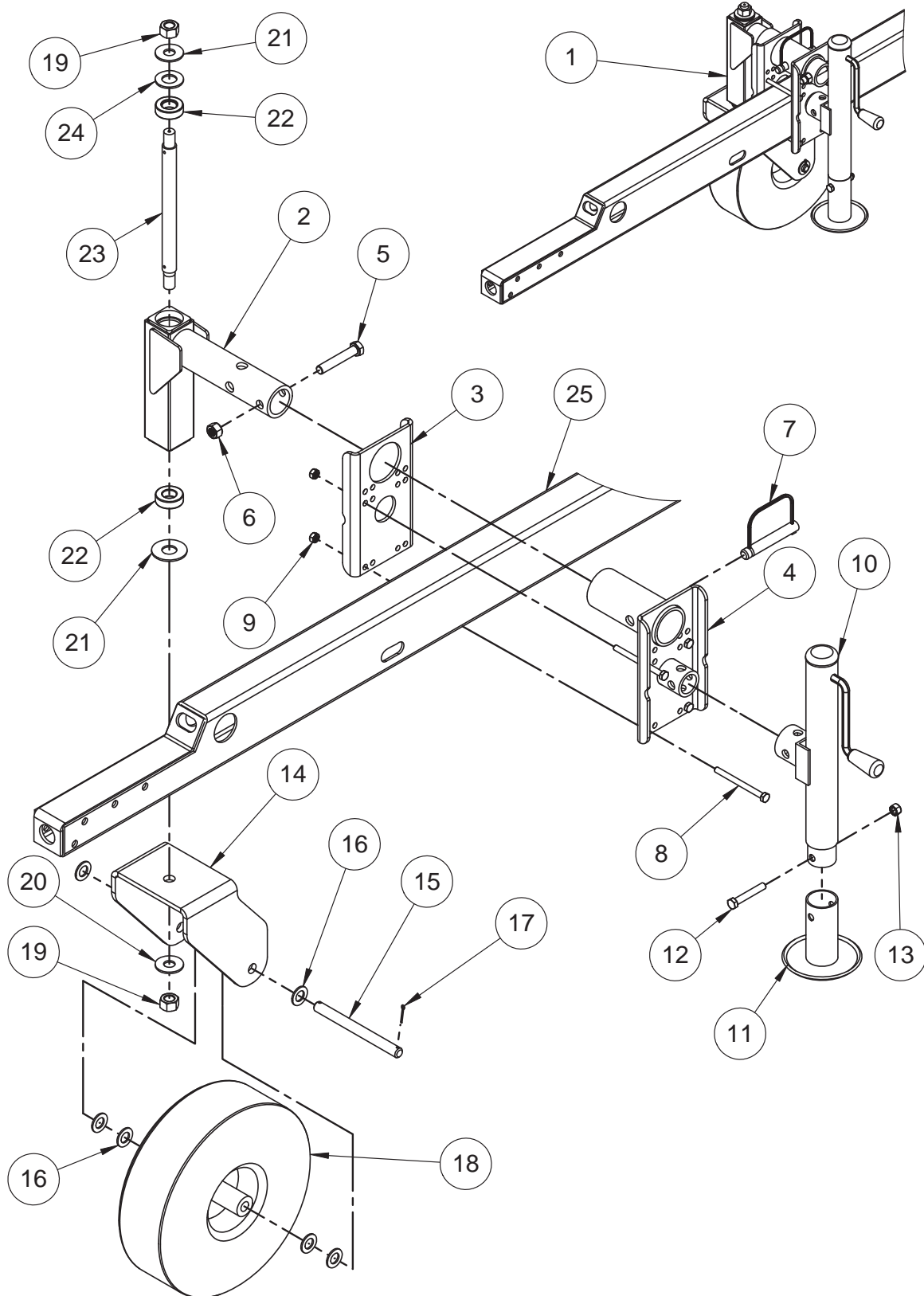

DOLLY WHEEL ASSEMBLY FOR DRIVE & SET OPTION

ITEM NO.	PART NUMBER	DESCRIPTION	QTY.
1	A-02350	Dolly Wheel 15in.	1
2	A-02359	Caster Mount	1
3	A-02351	Mount, Heavy Duty	1
4	A-02353	Attach Plate	1
5	0096-0035	Screw, Hex Head Cap - 16 X 90	1
6	0096-0044	Hex Nut with Nylon Insert - M16	1
7	0068-135	Lock Pin, Tension - 3/4 x 4	1
8	0096-0075	Screw, Hex Head Cap - M10 x 120	4
9	0096-0041	Hex Nut with Nylon Insert, M10	4
10	A-02169	Jack Assembly Replaces A-00144 Effective 2006	1
11	A-02354	Foot Pad	1
12	0096-0022	Screw, Hex Head Cap - M12 x 75	1
13	0096-0042	Hex Nut with Nylon Insert, M12	1
14	A-02365	Yoke, 15 Inch Wheel	1
15	A-02370	Jack Axle-8.25in	1
16	0096-0087	Flat Washer, M20	6
17	0090-0147	Pin, Cotter - 1/8 x 1 1/4	2
18	A-02367	Tire, Dolly Wheel 15 Inch	1
19	0096-0045	Hex Nut with Nylon Insert - M20	2
20	0090-0427	Flat Washer, 3/4	2
21	0090-0778	Flat Washer, 1	1
22	B25-00-0096	Bearing, Thrust	2
23	A-02363	Caster Pivot Shaft 15 Inch	1
24	0090-0429	Flat Washer, SAE 1	1
25	A-00170	Tongue Tube	Ref.

DOLLY WHEEL WITH TAPERED SWIVEL & YOKE ASSEMBLY (OPTION)

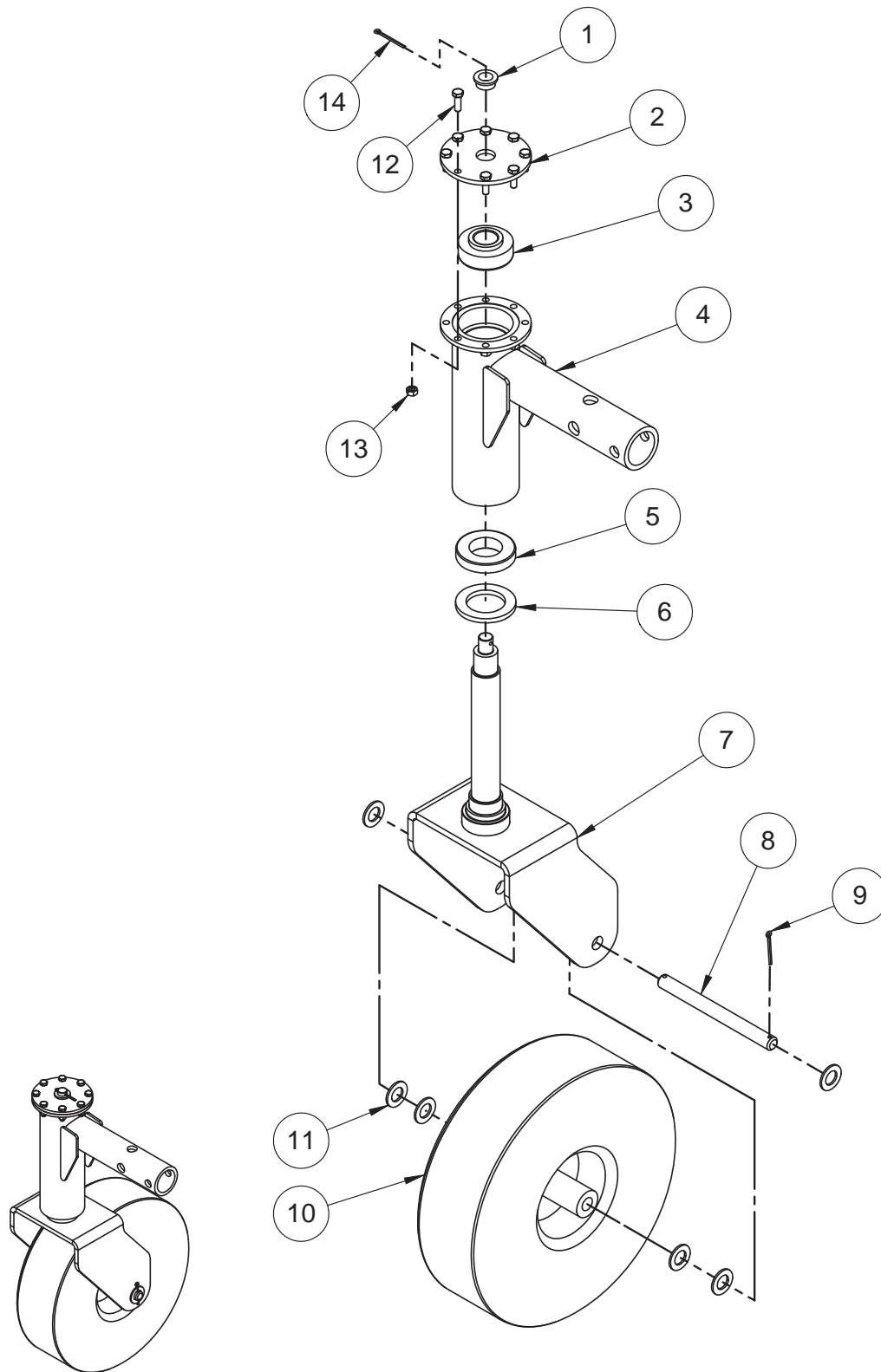

DOLLY WHEEL WITH TAPERED SWIVEL & YOKE ASSEMBLY (OPTION)

ITEM NO.	PART NUMBER	DESCRIPTION	QTY.
	A-02337	Swivel and Yoke Assembly	1
1	A-00056	Bearing, .75 I.D. x .5 O.D. x .125	1
2	A-02343	Cap, Bearing Housing	1
3	A-02341	Bearing, 1.25 I.D. x 2.875 O.D. x 1.1563	1
4	A-02347	Swivel Yoke Weldment	1
5	A-02340	Bearing, 1.75 I.D. x 3.125 O.D. x .6875	1
6	A-02342	Seal, 3.154 I.D. x .270 O.D. x 2.058	1
7	A-02348	Yoke Weldment	1
8	A-02370	Jack Axle	1
9	0090-0147	Pin, Cotter - 1/8 x 1 1/4	2
10	A-02367	Tire Dolly Wheel 15 Inch	1
11	0096-0087	Flat Washer, M20	6
12	0096-0011	Screw, Hex Head Cap - M8 x 25	8
13	0096-0040	Hex Nut with Nylon Insert - M8	8
14	0090-0881	Pin, Cotter - 5/32 x 2	1

BOOM REST SWITCH ASSEMBLY

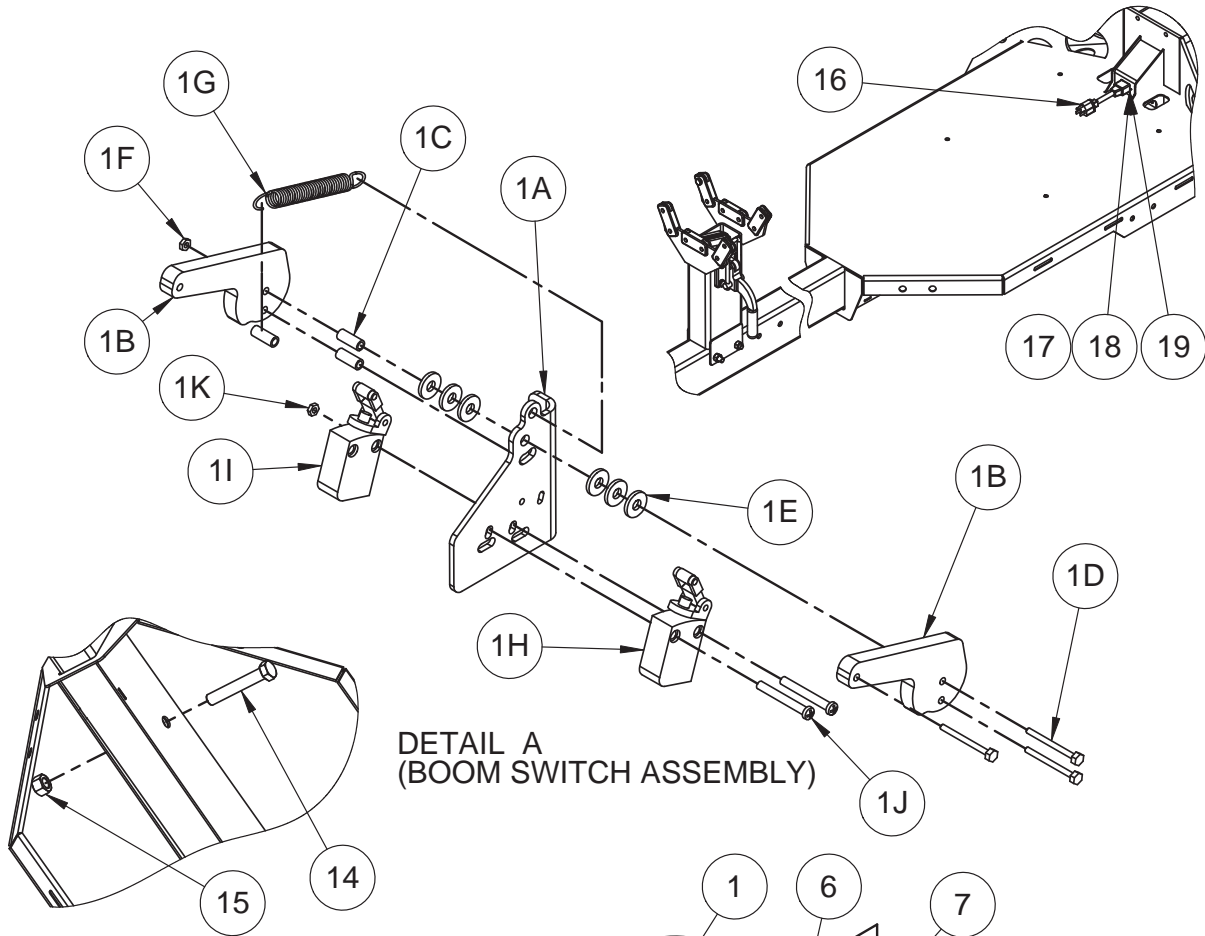

DETAIL A
(BOOM SWITCH ASSEMBLY)

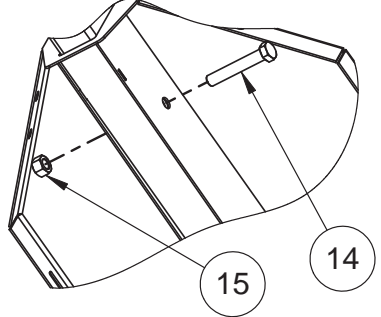

BOTTOM VIEW OF BASE

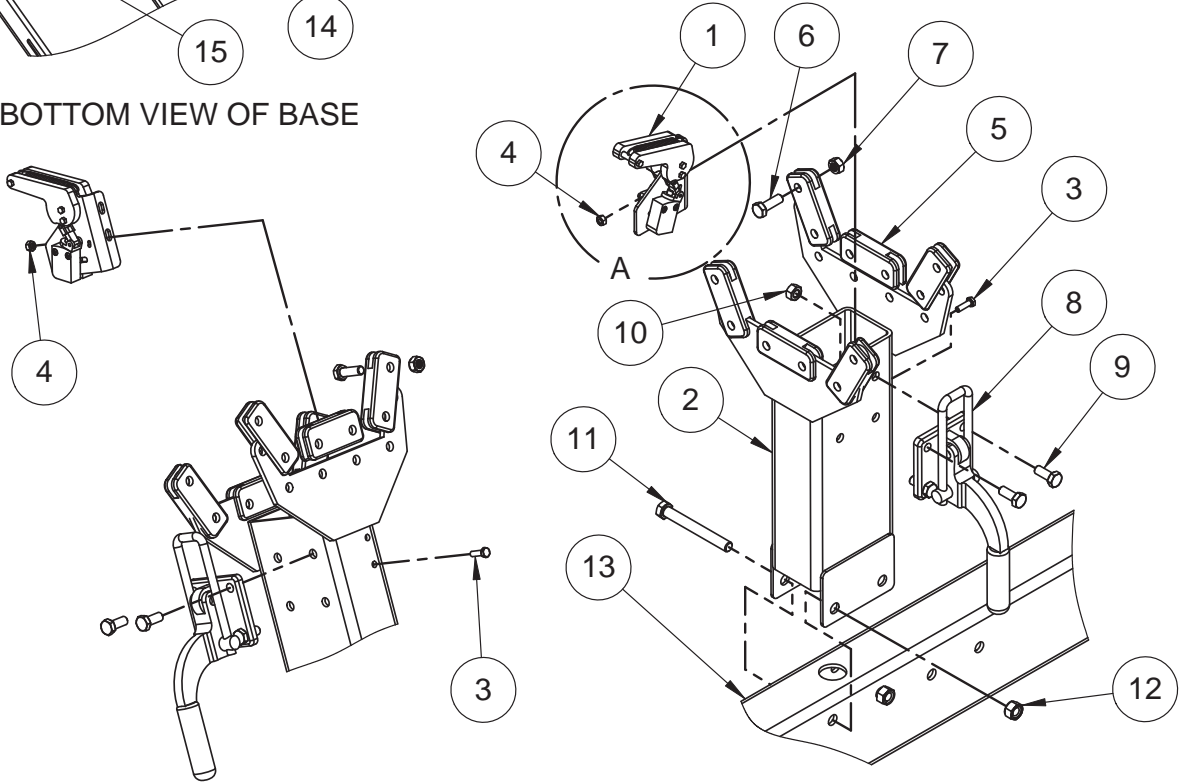

BOOM REST SWITCH ASSEMBLY

ITEM NO.	PART NUMBER	DESCRIPTION	QTY.
1	B03-00-0197	Boom Rest Switch Assembly	1
1A	A-00169	Switch Plate	1
1B	A-00188	Switch Cam	2
1C	A-00190	Spacer, Switch Cam Replaces A-00168 Effective 2007	3
1D	0096-0106	Screw, Hex Head Cap - M4 x 40	3
1E	0090-0419	Flat Washer, SAE - 1/4	6-7
1F	0096-0073	Hex Nut with Nylon Insert - M4	3
1G	A-00158	Spring, Extension	1
1H	A-03647	Switch Assembly NC Replaces B01-03-0079 Effective 2007	1
1I	A-03644	Switch Assembly NO Replaces B01-03-0078 Effective 2007	1
1J	0090-0821	Screw, Round Head Machine - 8-32 x 1 1/2	2
1K	0090-0181	Hex Nut with Nylon Insert - 8-32	2
2	A-00145	Front Rest	1
3	0096-0001	Screw, Hex Head Cap - M6 x 16	2
4	0096-0039	Hex Nut with Nylon Insert - M6	2
5	A-00157	Front Rest Pad	6
6	0096-0017	Screw, Hex Head Cap - M10 x 30	12
7	0096-0041	Hex Nut with Nylon Insert - M10	12
8	A-00159	Boom Latch	1
9	0096-0016	Screw, Hex Head Cap - M10 x 25	4
10	0096-0041	Hex Nut with Nylon Insert - M10	4
11	0096-0024	Screw, Hex Head Cap - M12 x 100	2
12	0096-0042	Hex Nut with Nylon Insert - M12	2
13	A-00170	Tongue Tube	Ref.
14	0096-0037	Screw, Hex Head Cap - M20 x 120	2
15	0096-0045	Hex Nut with Nylon Insert - M20	2
16	A-00179	Cord Assembly, 6"	1
17	A-00178	Connector, 16/20 Amp	1
18	A-00186	Lock, Connector	1
19	0090-1081	Screw, Pan Head Sheet Metal - # 4 x 3/4	2

OUTRIGGER LEG ASSEMBLY

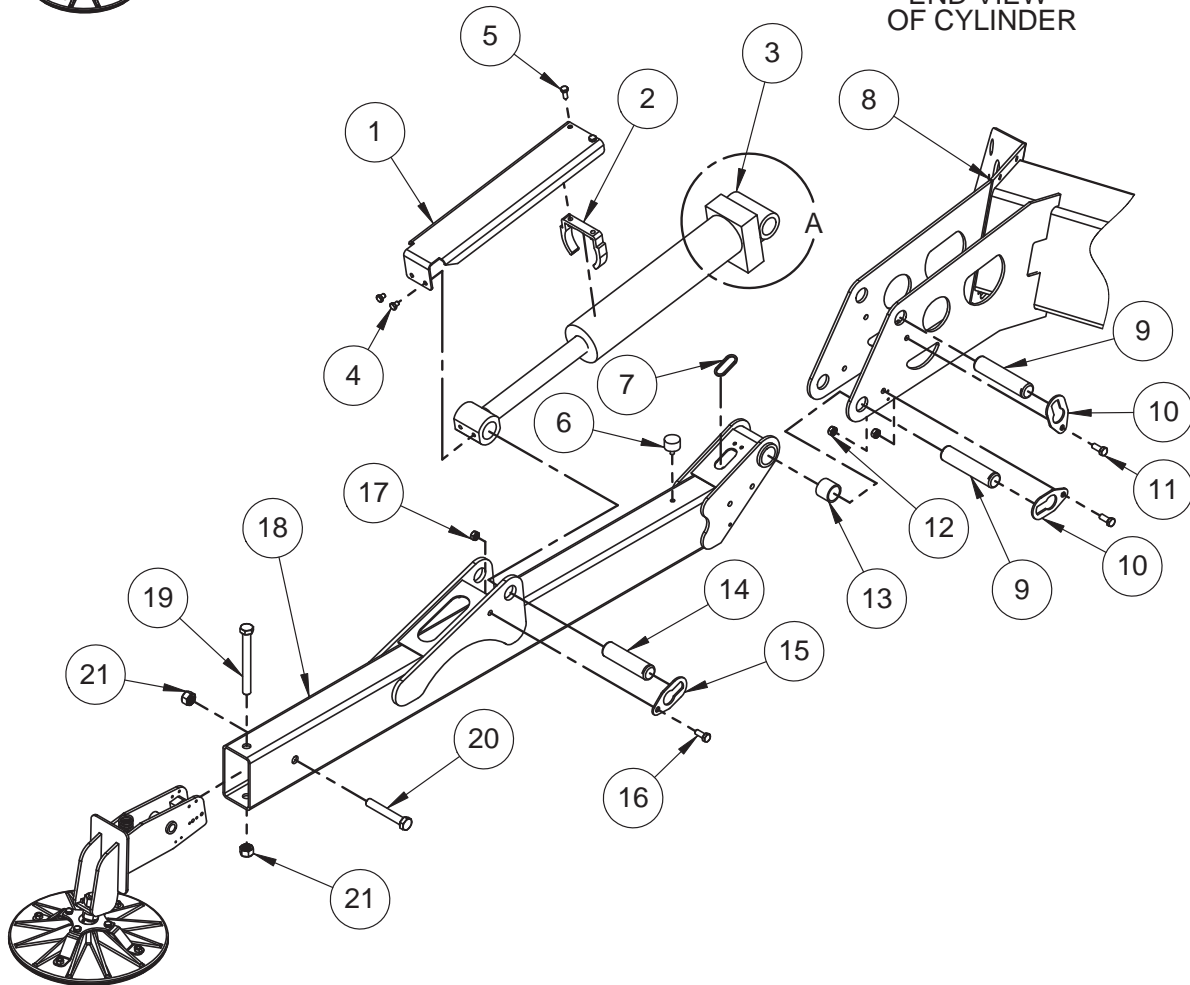
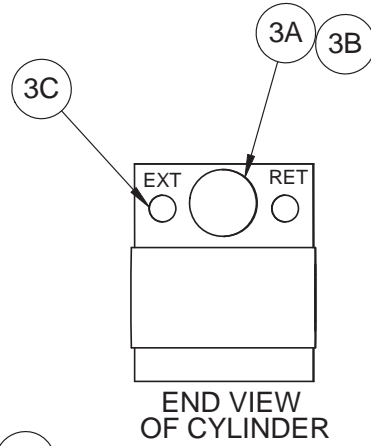
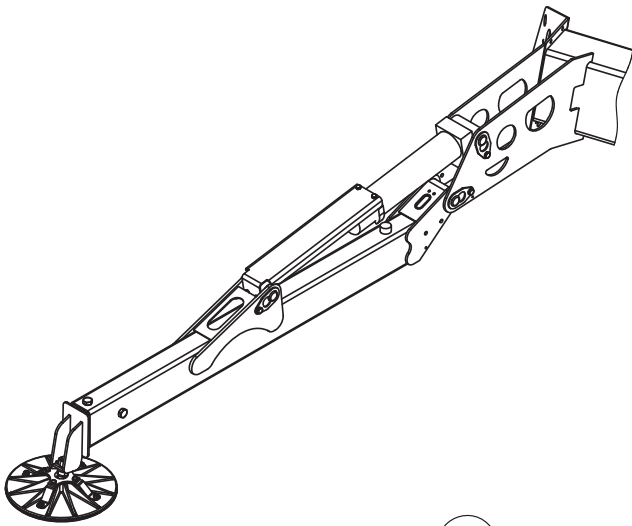

OUTRIGGER LEG ASSEMBLY

ITEM NO.	PART NUMBER	DESCRIPTION	QTY.
* Quantities listed reflect the number of parts needed for EACH Outrigger *			
1	A-00141	Outrigger Cylinder Guard	1
2	A-00142	Guard Slide	1
3	A-00138	Outrigger Cylinder	1
3A	B02-04-0118	Valve Replaces B02-04-0102 Effective 2007	1
3B	B01-08-0022	Coil Replaces B02-15-0493-A Effective 2007	1
NOTE: If the Coil is of Metal casing replace with B01-08-0022 Coil If the Coil is of Plastic casing replace with both B01-08-0022 Coil and B02-04-0118 Valve			
3C	B02-14-0087	Orifice Disc	1
3D	B02-14-0107	Check Valve - Not Shown	1
3E	B02-13-0129	Packing Kit - Not Shown	1
4	0096-0009	Screw, Hex Head Cap - M8 x 10	2
5	0096-0010	Screw, Hex Head Cap - M8 x 20	2
6	B20-00-0019	Bumper, Single Stud 1.25" Diameter	1
7	A-00046	Grommet, 1.5 x 1.25 x 1.75	1
8	A-00100	Base Weldment	Ref.
9	A-00020	Pin, 1.25 x 5.5	2
10	A-00019	Pin Retainer, 1.25	2
11	0096-0016	Screw, Hex Head Cap - M10 x 25	2
12	0096-0041	Hex Nut with Nylon Insert - M10	2
13	A-00032	Composite Bearing, 1.25 x 1.50 x 1.25	2
14	A-00022	Pin, 1.25 x 4.25	1
15	A-00019	Pin Retainer, 1.25	1
16	0096-0016	Screw, Hex Head Cap - M10 x 25	1
17	0096-0041	Hex Nut with Nylon Insert - M10	1
18	A-00120	Outrigger Weldment	1
19	0096-0036	Screw, Hex Head Cap - M16 x 150	1
20	0096-0051	Screw, Hex Head Cap - M16 x 100	1
21	0096-0044	Hex Nut with Nylon Insert - M16	2

OUTRIGGER FOOT ASSEMBLY

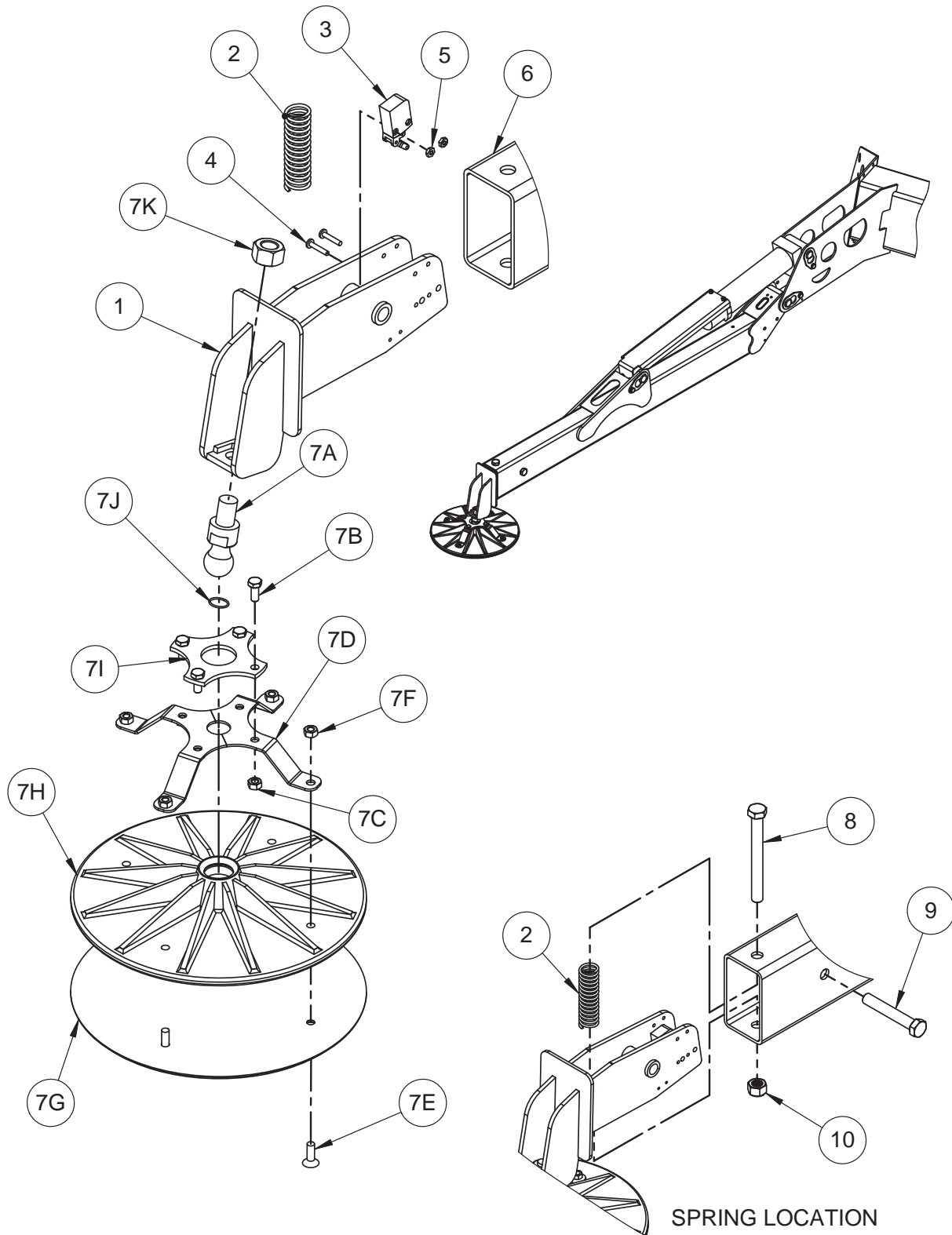

OUTRIGGER FOOT ASSEMBLY

ITEM NO.	PART NUMBER	DESCRIPTION	QTY.
* Quantities listed reflect the number of parts needed for EACH Outrigger *			
1	A-00128	Pad Mount Weldment	1
2	A-00154	Spring, Outrigger Sensor	1
3	A-03644	Switch Assembly NO Replaces B01-03-0078 Effective 2007	1
4	0090-0692	Screw, Round Head Machine - 8-32 X 1 1/4	2
5	0090-0181	Hex Nut with Nylon Insert - 8-32	2
6	A-00120	Outrigger Weldment	1
7	A-00136-K	Foot Pad Kit	1
7A	A-00135	Foot Pad Ball	1
7B	0096-0010	Screw, Hex Head Cap - M8 x 20	4
7C	0096-0040	Hex Nut with Nylon Insert - M8	4
7D	A-00127	Foot Pad Lock Replaces A-00769 Effective 2007	2
7E	0096-0121	Screw, Flat Head Cap - M8 x 30	4
7F	0096-0040	Hex Nut with Nylon Insert - M8	4
7G	A-00137	Foot Pad Bottom - 12"	1
7H	A-00136	Foot Pad, Aluminum -12"	1
7I	A-00139	Footpad Cap	1
7J	A-00195	O-ring, 1 1/4 O.D. x 1 I.D.	1
7K	0096-0045	Hex Nut with Nylon Insert - M20	1
	B22-00-0053	Retrofit Kit - Footpad	1
7B	0096-0010	Screw, Hex Head Cap - M8 x 20	4
7C	0096-0040	Hex Nut with Nylon Insert - M8	8
7E	0096-0121	Screw, Flat Head Cap - M8 x 30 Replaces 0096-0012 Effective 2007	4
7D	A-00127	Foot Pad Lock Replaces A-00769 Effective 2007	2
7I	A-00139	Footpad Cap Replaces A-00769 Effective 2007	1
8	0096-0036	Screw, Hex Head Cap - M16 x 150	1
9	0096-0051	Screw, Hex Head Cap - M16 x 100	1
10	0096-0044	Hex Nut with Nylon Insert - M16	2

BRAKE AND AXLE ASSEMBLY

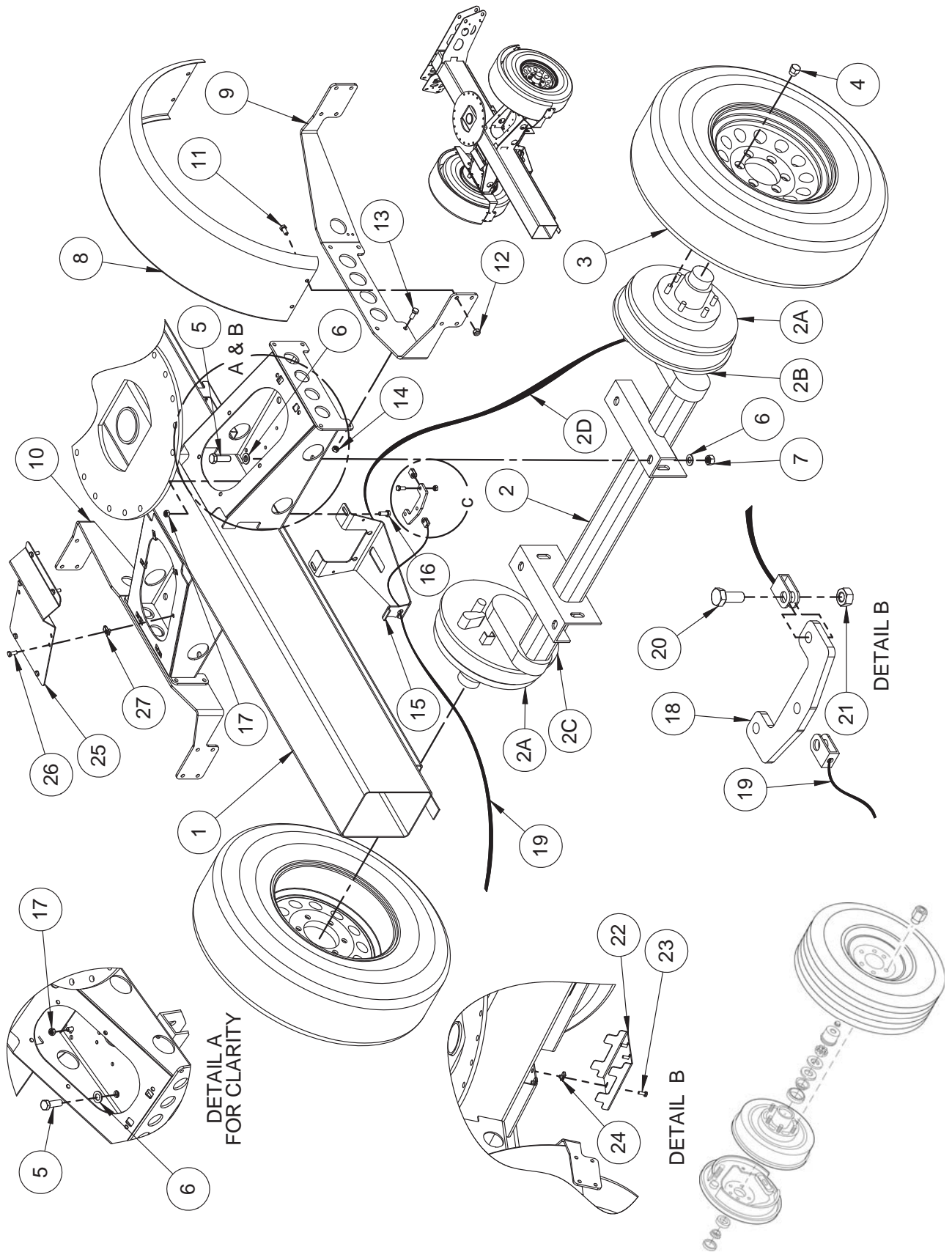

BRAKE AND AXLE ASSEMBLY

ITEM NO.	PART NUMBER	DESCRIPTION	QTY.
1	A-00100	Base Weldment	Ref.
2	A-05119	Axle Replaces A-00119 Effective 2008	1
2A	B10-00-0049	Brake Drum and Wheel Hub Assembly	2
2B	B10-00-0047	Brake Assembly, Left - Driver Side Replaces B10-00-0042 Effective 2008	1
2C	B10-00-0048	Brake Assembly, Right - Passenger Side Replaces B10-00-0043 Effective 2008	1
2D	B40-00-0035	Brake Cable	2
2 - 1	A-05119-E	Axle, Electric Brakes - Option	1
3	B08-02-0031	Wheel Assembly	2
3A	B08-02-0004	Tire	2
3B	B32-00-0016	Hub Cap - Not Shown	2
4	0090-1075	Lug Nut	12
5	0096-0034	Screw, Hex Head Cap - M16 x 40	4
6	0096-0050	Flat Washer, M16	8
7	0096-0044	Hex Nut with Nylon Insert - M16	4
8	A-00143	Fender	2
9	A-00151-1	Fender Mount – Left	1
10	A-00151-2	Fender Mount – Right	1
11	0096-0014	Screw, Hex Head Cap - M10 x 20	8
12	0096-0041	Hex Nut with Nylon Insert - M10	8
13	0096-0016	Screw, Hex Head Cap - M10 x 25	8
14	0096-0041	Hex Nut with Nylon Insert - M10	8
15	A-00176	Cable Bracket Mount	1
16	0096-0016	Screw, Hex Head Cap - M10 x 25	2
17	0096-0041	Hex Nut with Nylon Insert - M10	2
18	A-00184	Equalizer Bracket	1
19	A-00187	Cable Assembly, Parking Brake	1
20	0096-0010	Screw, Hex Head Cap - M8 x 20	3
21	0096-0040	Hex Nut with Nylon Insert - M8	3
22	A-00175	Hydraulic Cover	1
23	0096-0011	Screw, Hex Head Cap - M8 x 25	4
24	0096-0067	Nut Clip, M8	4
25	A-00932	Manifold Cover	1
26	0096-0067	Screw, Hex Head Cap - M8 x 25	12
27	0096-0011	Nut Clip, M8	12
28	B21-00-0026	Brake Line Kit - Hydraulic Brakes - Not Shown	1

BRAKE AND AXLE ASSEMBLY FOR DRIVE & SET OPTION

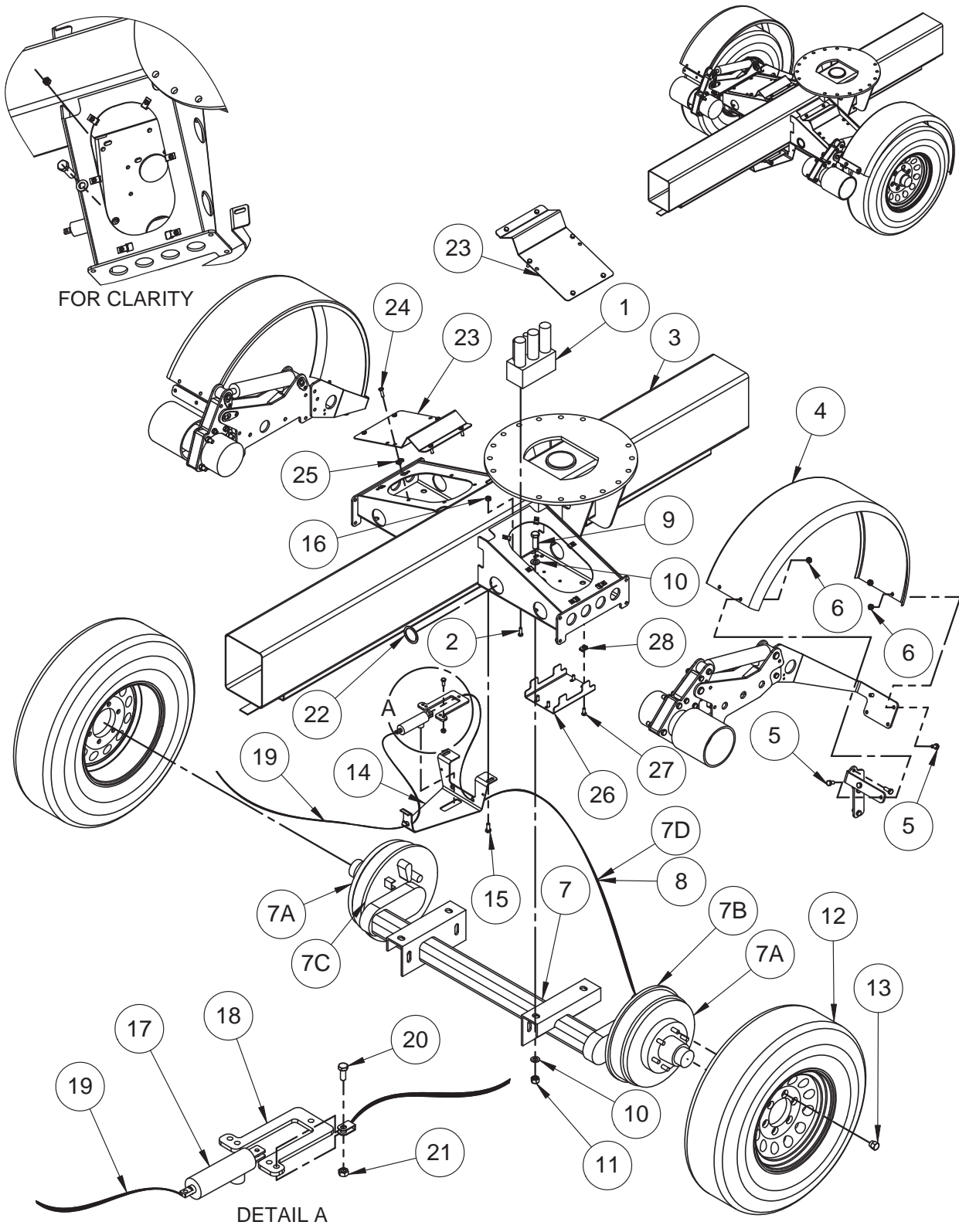

BRAKE AND AXLE ASSEMBLY FOR DRIVE & SET OPTION

ITEM NO.	PART NUMBER	DESCRIPTION	QTY.
1	A-00928	Manifold	1
2	0096-0011	Screw, Hex Head Cap - M8 x 25	2
3	A-00100	Base Weldment	Ref.
4	A-00143	Fender	2
5	0096-0014	Screw, Hex Head Cap - M10 x 20	8
6	0096-0041	Hex Nut with Nylon Insert - M10	8
7	A-05119	Axle Replaces A-00119 Effective 2008	1
7A	B10-00-0049	Brake Drum and Wheel Hub Assembly	2
7B	B10-00-0047	Brake Assembly, Left - Driver Side Replaces B10-00-0042 Effective 2008	1
7C	B10-00-0048	Brake Assembly, Right - Passenger Side Replaces B10-00-0043 Effective 2008	1
7D	B40-00-0035	Brake Cable - Hydraulic Surge Brake	2
7 - 1	A-05119-E	Axle, Electric Brakes	1
8	A-00223	Cable - Parking Brake - Electric Surge Brake	2
9	0096-0034	Screw, Hex Head Cap - M16 x 40	4
10	0096-0050	Flat Washer, M16	8
11	0096-0044	Hex Nut with Nylon Insert - M16	4
12	B08-02-0031	Wheel Assembly Replaces B08-02-0023 Effective 2008	2
12A	B08-02-0004	Tire	2
12B	B32-00-0016	Hub Cap - Not Shown	2
13	0090-1075	Lug Nut	12
14	A-00176	Cable Brake Mount - Hydraulic Surge Brake	1
14A	A-00166	Cable Brake Mount - Electric Surge Brake	1
15	0096-0010	Screw, Hex Head Cap - M8 x 20	3
16	0096-0040	Hex Nut with Nylon Insert - M8	3
17	A-00930	Cylinder, Brake - Hydraulic Surge Brake	1
17A	A-00945	Cylinder Brake - Electric Surge Brake	1
18	A-00936	Equalizer Bracket	1
19	A-00187	Cable Assembly, Parking Brake	1
20	0096-0016	Screw, Hex Head Cap - M10 x 25	2
21	0096-0041	Hex Nut with Nylon Insert - M10	2
22	A-00941	Grommet,	7
23	A-00932	Manifold Cover	2
24	0096-0011	Screw, Hex Head Cap - M8 x 25	12
25	0096-0067	Nut Clip, M8	12
26	A-00175	Hydraulic Cover	1
27	0096-0011	Screw, Hex Head Cap - M8 x 25	4
28	0096-0067	Nut Clip, M8	4
29	B21-00-0026	Brake Line Kit - Hydraulic Brakes - Not Shown	1

DRIVE MOTOR ASSEMBLY FOR DRIVE & SET OPTION

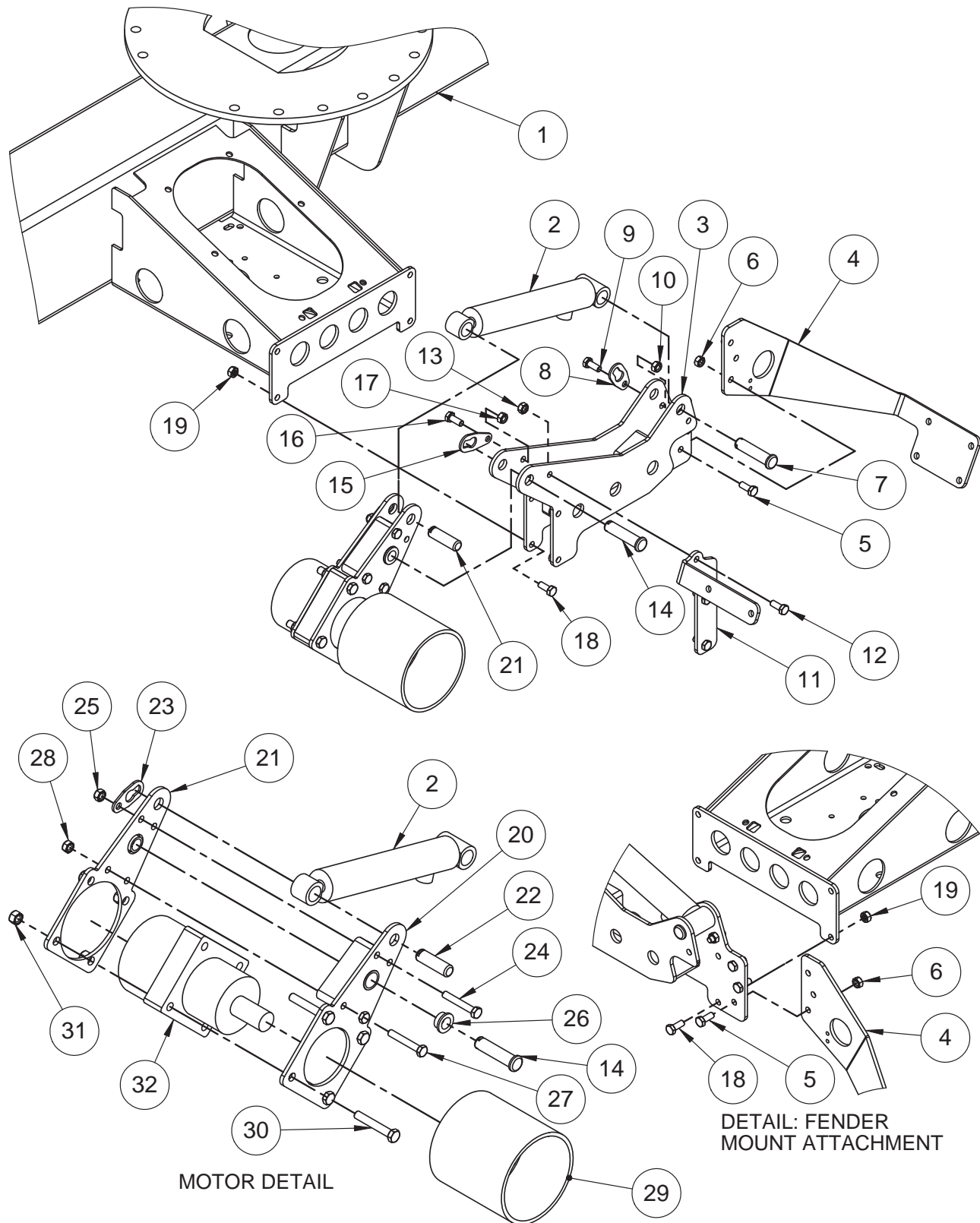

DRIVE MOTOR ASSEMBLY FOR DRIVE & SET OPTION

ITEM NO.	PART NUMBER	DESCRIPTION	QTY.
1	A-00100	Base Weldment	Ref.
2	A-00906	Cylinder	2
3	A-00901L	Mount Weldment, Driver Side - Hydraulic Surge Brake	1
3A	A-00950L	Mount Weldment, Driver Side - Electric Surge Brake	1
3B	A-00901R	Mount Weldment, Passenger Side - Hydraulic Surge Brake	1
3C	A-00950R	Mount Weldment, Passenger Side - Electric Surge Brake	1
4	A-00908L	Fender Mount, Rear - Driver Side	1
4A	A-00908R	Fender Mount, Rear - Passenger Side	1
5	0096-0016	Screw, Hex Head Cap - M10 x 25	6
6	0096-0041	Hex Nut with Nylon Insert - M10	6
7	A-00927	Pin with Head, .75 X 3.25	2
8	A-00017	Pin, Retainer .75	2
9	0096-0016	Screw, Hex Head Cap - M10 x 25	2
10	0096-0041	Hex Nut with Nylon Insert - M10	2
11	A-00907-1	Fender Mount, Left	1
11A	A-00907-2	Fender Mount, Right	1
12	0096-0016	Screw, Hex Head Cap - M10 x 25	6
13	0096-0041	Hex Nut with Nylon Insert - M10	6
14	A-00927	Pin with Head, .75 X 3.25	2
15	A-00017	Pin, Retainer .75	2
16	0096-0016	Screw, Hex Head Cap - M10 x 25	2
17	0096-0041	Hex Nut with Nylon Insert - M10	2
18	0096-0016	Screw, Hex Head Cap - M10 x 25	8
19	0096-0041	Hex Nut with Nylon Insert - M10	8
20	A-00910	Pivot Weldment	2
21	A-00912	Pivot Arm "B"	2
22	A-00926	Pin, .75 X 2.5	2
23	A-00925	Pin Retainer, .75	2
24	0096-0066	Screw, Hex Head Cap - M10 x 60	4
25	0096-0041	Hex Nut with Nylon Insert - M10	4
26	A-00056	Bearing	4
27	0096-0066	Screw, Hex Head Cap - M10 x 60	4
28	0096-0041	Hex Nut with Nylon Insert - M10	4
29	A-00920	Friction Wheel	2
30	0096-0022	Screw, Hex Head Cap - M12 x 75	8
31	0096-0042	Hex Nut with Nylon Insert - M12	8
32	A-00915	Motor, Hydraulic	2

SLEW RING ASSEMBLY

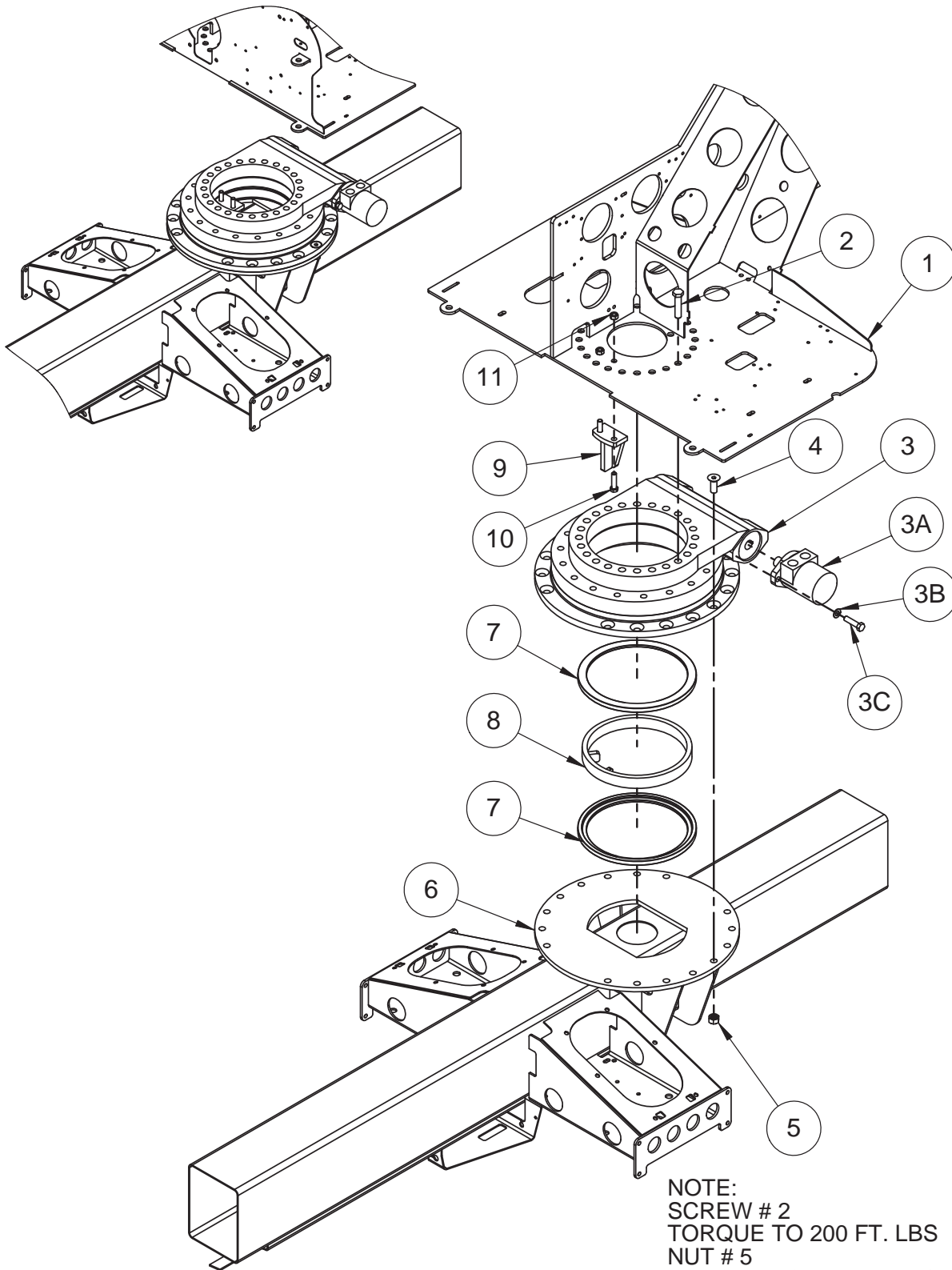

NOTE:
 SCREW # 2
 TORQUE TO 200 FT. LBS
 NUT # 5
 TORQUE TO 200 FT. LBS

SLEW RING ASSEMBLY

ITEM NO.	PART NUMBER	DESCRIPTION	QTY.
1	A-00200	Turntable Weldment	Ref.
2	0090-0643	Screw, Hex Head Cap - 5/8-11 x 2 3/4 – Grade 8 NOTE: Torque to 200 ft-lb	19
3	A-02189	Slew Ring and Adapter Assembly	1
3A	B02-06-0018	Drive Motor - 80cc	1
3B	0090-0461	Screw, Hex Head Cap - 1/2-13 x 2	2
3C	0090-0212	Washer, Lock - 1/2	2
4	0096-0054	Screw, Flat Head Cap - M16 x 50	16
5	0090-0044	Hex Nut with Nylon Insert, M16 NOTE: Torque to 200 ft-lb	16
6	A-00100	Base Weldment	Ref.
7	A-00351	Nylon Ring	2
8	A-00352	Ring	1
9	A-00356	Ring Stop Weldment	1
10	0096-0021	Screw, Hex Head Cap - M12 x 45	2
11	0096-0042	Hex Nut with Nylon Insert, M12	2
12	B02-01-0282	Hose, Hydraulic # 2 x 20 in - Not Shown	1
13	B00-00-0061	Zerk Grease 1/8 in NPT 90° - Not Shown	1
14	B02-02-0241	Coupling, Fitting - Not Shown	1
15	B02-13-0144	Seal Kit - Not Shown	1
16	A-00191	Cap Seal for Slew Ring - Not Shown	1

BATTERY COMPARTMENT ASSEMBLY

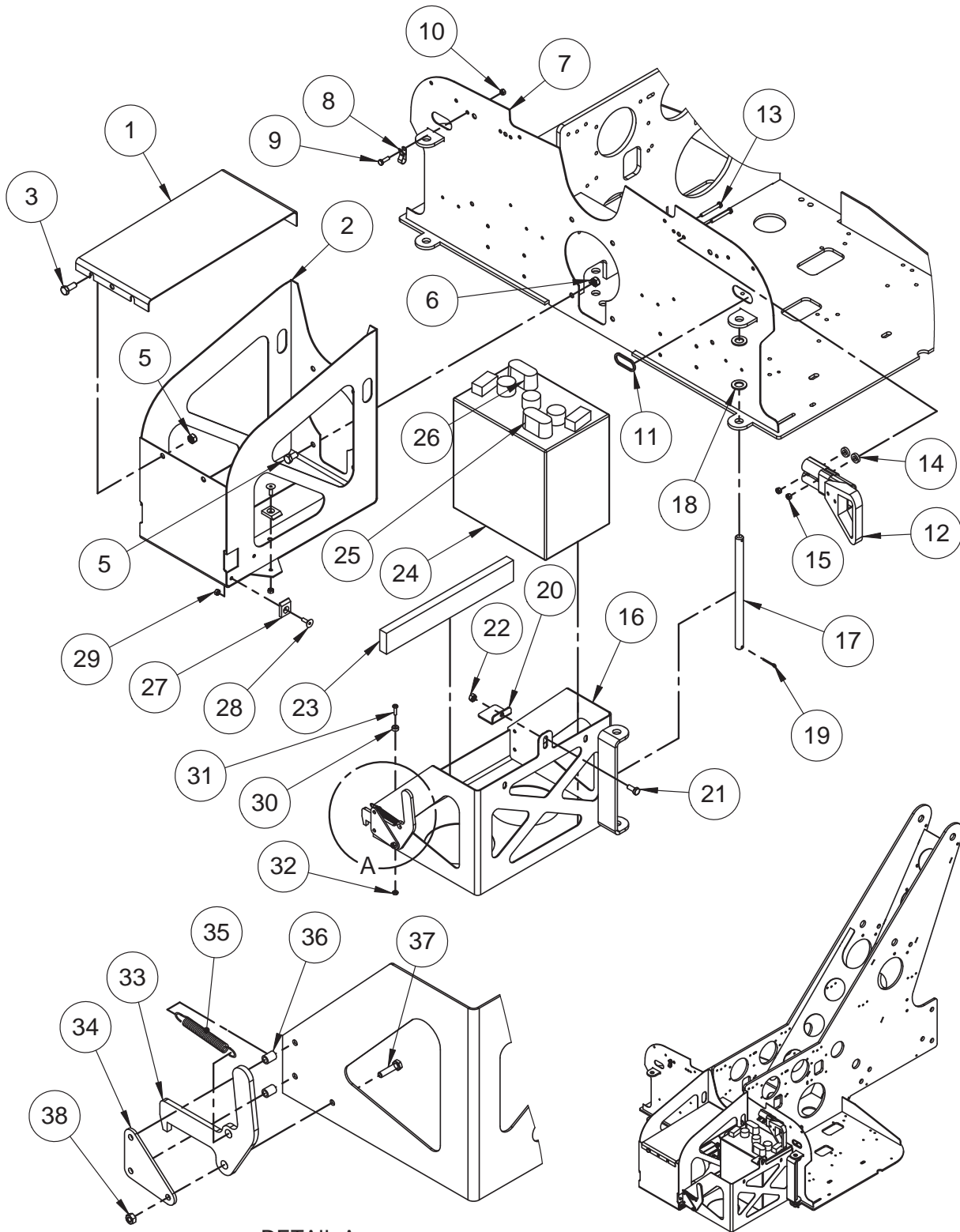

DETAIL A

BATTERY COMPARTMENT ASSEMBLY

ITEM NO.	PART NUMBER	DESCRIPTION	QTY.
1	A-00256	Motor Cover	1
2	A-00225	Nose Weldment	1
3	0096-0016	Screw, Hex Head Cap - M10 x 25	2
4	0096-0041	Hex Nut with Nylon Insert, M10	2
5	0096-0014	Screw, Hex Head Cap - M10 x 20	4
6	0096-0041	Hex Nut with Nylon Insert, M10	4
7	A-00200	Turntable Weldment	Ref.
8	B04-07-0036	Clamp	2
9	0096-0002	Screw, Hex Head Cap - M6 x 20	2
10	0096-0039	Hex Nut with Nylon Insert, M6	2
11	A-00046	Grommet	4
12	A-00272	Battery Cable Kit	1
12A	B01-09-0132	A-Frame Connector Handle	1
12B	B01-09-0131	Connector Plug	1
13	0096-0052	Screw, Hex Head Cap - M6 x 40	2
14	0096-0047	Washer, Nylon - M10	2
15	0096-0039	Hex Nut with Nylon Insert, M6	2
16	A-00215	Battery Box Weldment – Driver Side	1
16A	A-00220	Battery Box Weldment – Passenger Side	1
17	A-00278	Hinge Pin	2
18	0096-0050	Washer, Flat, M16	4
19	0090-0147	Cotter Pin, 1/8 x 1 1/4	4
20	A-00271	Battery Hold Down Plate	2
21	0096-0010	Screw, Hex Head Cap - M8 x 20	2
22	0096-0040	Hex Nut with Nylon Insert, M8	2
23	A-00222	Battery Tray Spacer	2
24	A-00242	Battery, 6 Volt	4
25	B01-09-0133	Terminal Boot – Black	4
26	B01-09-0134	Terminal Boot – Red	4
27	A-00037	Ramp – Short	4
28	0096-0003	Screw, Flat Head Cap - M6 x 20	4
29	0096-0039	Hex Nut with Nylon Insert, M6	4
30	A-00209	Rubber Bumper	4
31	0096-0236	Screw, Round Head Machine - 10-24 x 3/4	4
32	0090-0182	Hex Nut with Nylon Insert, #10-24	4
33	A-00219	Battery Box Latch	2
34	A-00229	Battery Latch Plate	2
35	A-00244	Tension Spring	2
36	A-00234	Spacer	4
37	0096-0004	Screw, Hex Head Cap - M6 x 25	6
38	0096-0039	Hex Nut with Nylon Insert, M6	6

CONTROL COMPARTMENT ASSEMBLY

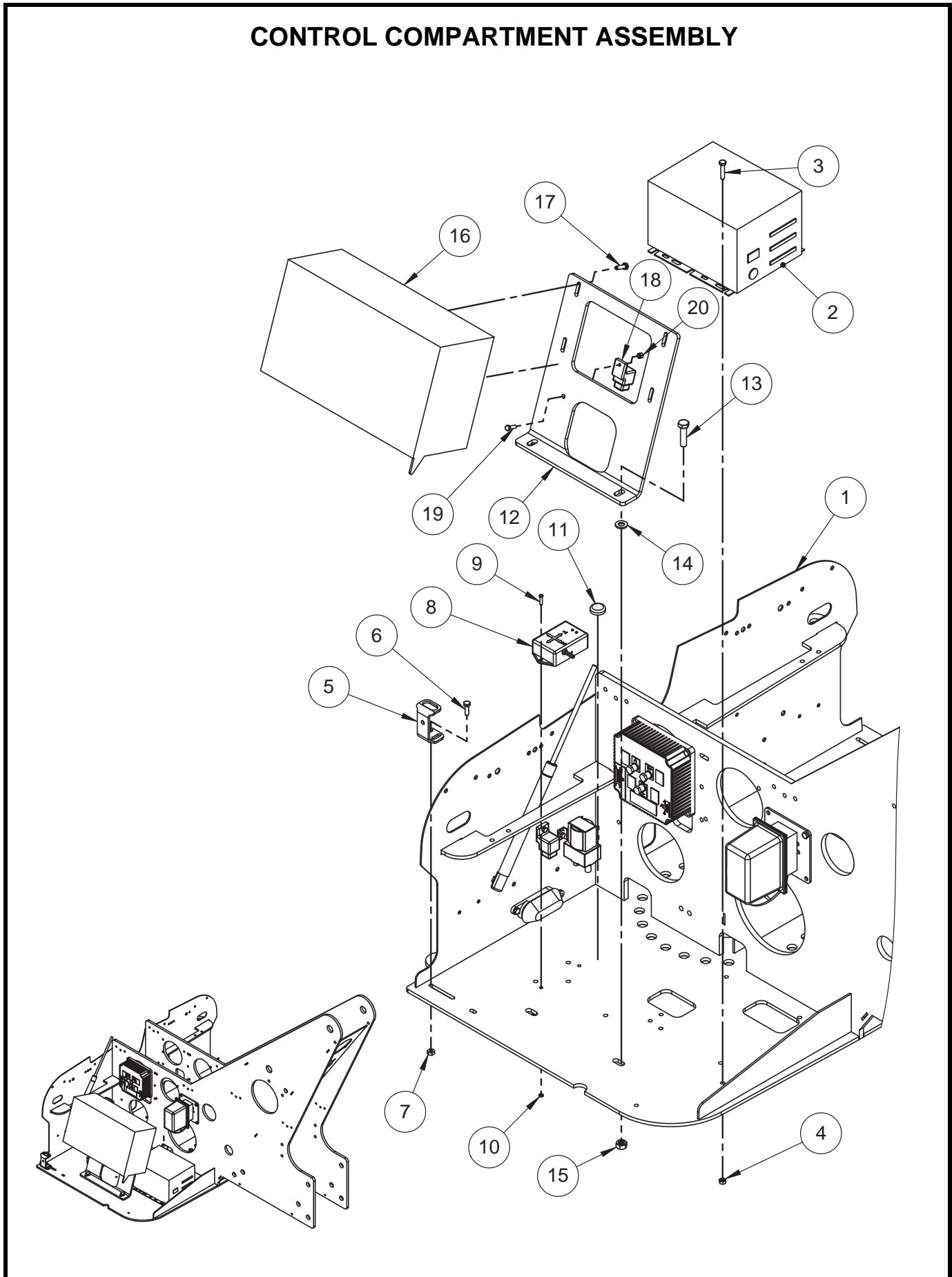

CONTROL COMPARTMENT ASSEMBLY

ITEM NO.	PART NUMBER	DESCRIPTION	QTY.
1	A-00200	Turntable Weldment	Ref.
2	B01-05-0056	Battery Charger 24V / 40A Linear	1
3	0096-0002	Screw, Hex Head Cap - M6 x 20	4
4	0096-0039	Hex Nut with Nylon Insert, M6	4
5	A-00290	Cover Stop Bracket Replaces A-00277L Effective 2007	1
6	0096-0002	Screw, Hex Head Cap - M6 x 20	2
7	0096-0039	Hex Nut with Nylon Insert, M6	2
8	A-00294	Level Sensor Replaces A-00259 Effective 2007	1
9	0096-0113	Screw, Hex Head Cap - M4 x 16	2
10	0096-0073	Hex Nut with Nylon Insert, M4	2
11	B00-00-0001	Bubble Level, Bull's-eye	1
12	A-00233	Lower Control Mount	1
13	0096-0018	Screw, Hex Head Cap - M10 x 40	2
14	0096-0047	Washer, Nylon - M10	2
15	0096-0041	Hex Nut with Nylon Insert, M10	2
16	A-00238	Lower Control Box	1
16A	A-00082	Loop Back Plug	1
16B	B38-00-0001	Replacement Key - Not Shown	2
17	0096-0002	Screw, Hex Head Cap - M6 x 20	4
18	B01-06-0053	Relay, 24Volts DC 20 Amp with Mounting Bracket	1
19	0096-0125	Screw, Hex Head Cap - M5 x 16	1
20	0096-0126	Hex Nut with Nylon Insert, M5	1

CONTROL COMPARTMENT ASSEMBLY (CONTINUED)

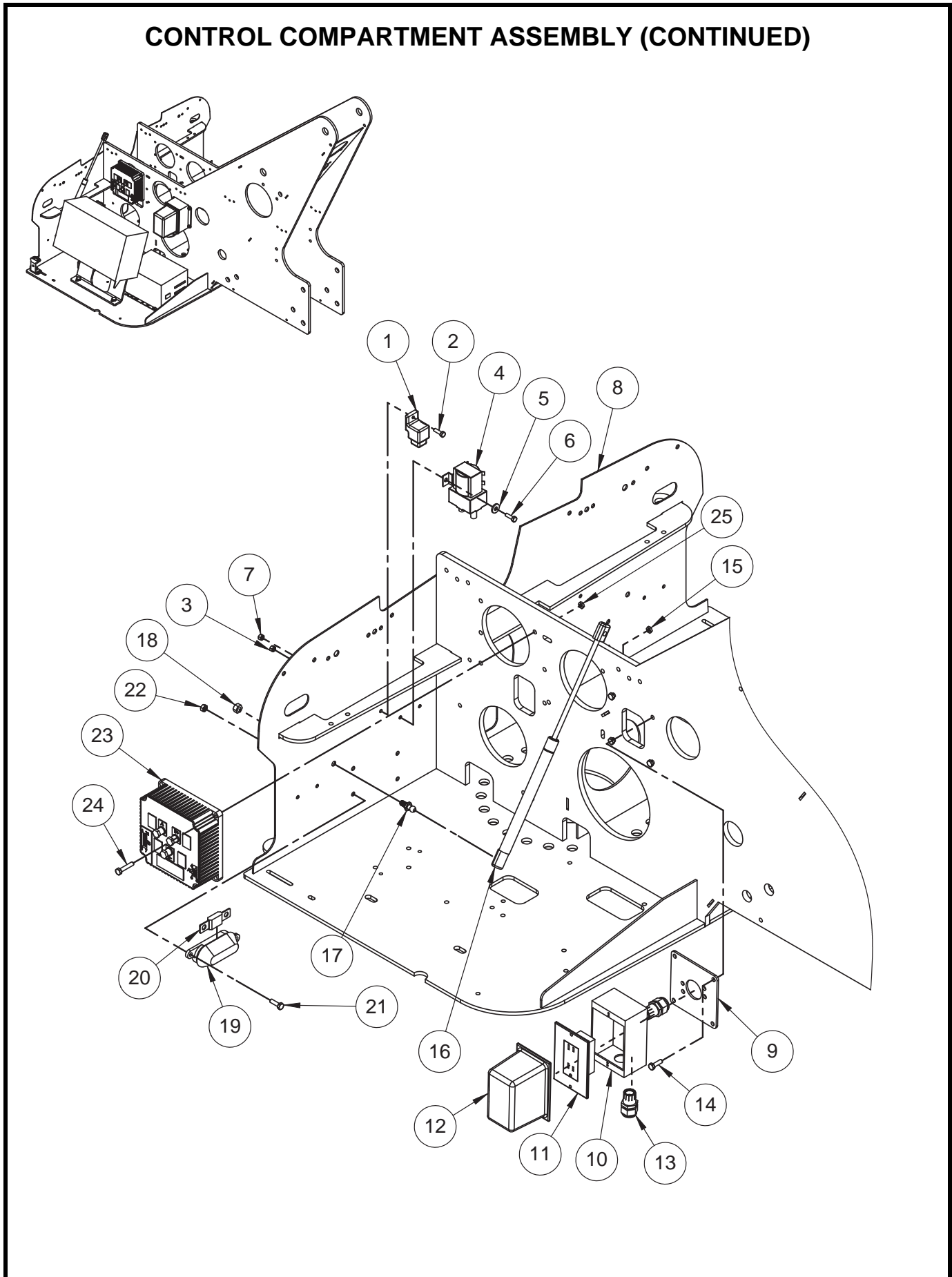

CONTROL COMPARTMENT ASSEMBLY (CONTINUED)

ITEM NO.	PART NUMBER	DESCRIPTION	QTY.
1	B01-06-0053	Relay, 24V DC 20 Amp with Mounting Bracket	1
2	0096-0125	Screw, Hex Head Cap - M5 x 16	2
3	0096-0126	Hex Nut with Nylon Insert, M5	2
4	B01-06-0058	Contact, 24 Volts DC	1
5	0096-0061	Washer, Flat - M4	4
6	0096-0113	Screw, Hex Head Cap - M4 x 16	2
7	0096-0073	Hex Nut with Nylon Insert, M4	2
8	A-00200	Turntable Weldment	Ref.
9	A-00287	GFI Mount Plate	1
10	B01-10-0046	Outlet Box - Weather Tite	1
10A	0096-0002	Screw, Hex Head Cap - M6 x 20 - Not Shown	2
10B	0096-0039	Hex Nut with Nylon Insert, M6 - Not Shown	2
11	B01-10-0034	Receptacle - GFI	1
12	A-00288	Cover, Clear Plastic	1
13	B01-09-0029	Cord Grip, Plastic 1/2in	2
14	0096-0002	Screw, Hex Head Cap - M6 x 20	4
15	0096-0039	Hex Nut with Nylon Insert, M6	4
16	A-00274	Gas Spring	1
17	0090-0920	Ball Stud, 10MM	1
18	0090-0185	Hex Nut, Self-Locking, #5/16-18	1
19	B01-10-0331	Fuse Holder	1
20	B01-10-0330	Fuse, 200 Amp	1
21	0096-0001	Screw, Hex Head Cap - M6 x 16	2
22	0096-0039	Hex Nut with Nylon Insert, M6	2
23	A-00297	Motor Controller Replaces A-00255 Effective 2008	1
24	0096-0131	Screw, Hex Head Cap - M6 x 30	4
25	0096-0039	Hex Nut with Nylon Insert, M6	4

CONTROL COMPARTMENT ASSEMBLY FOR DRIVE & SET OPTION

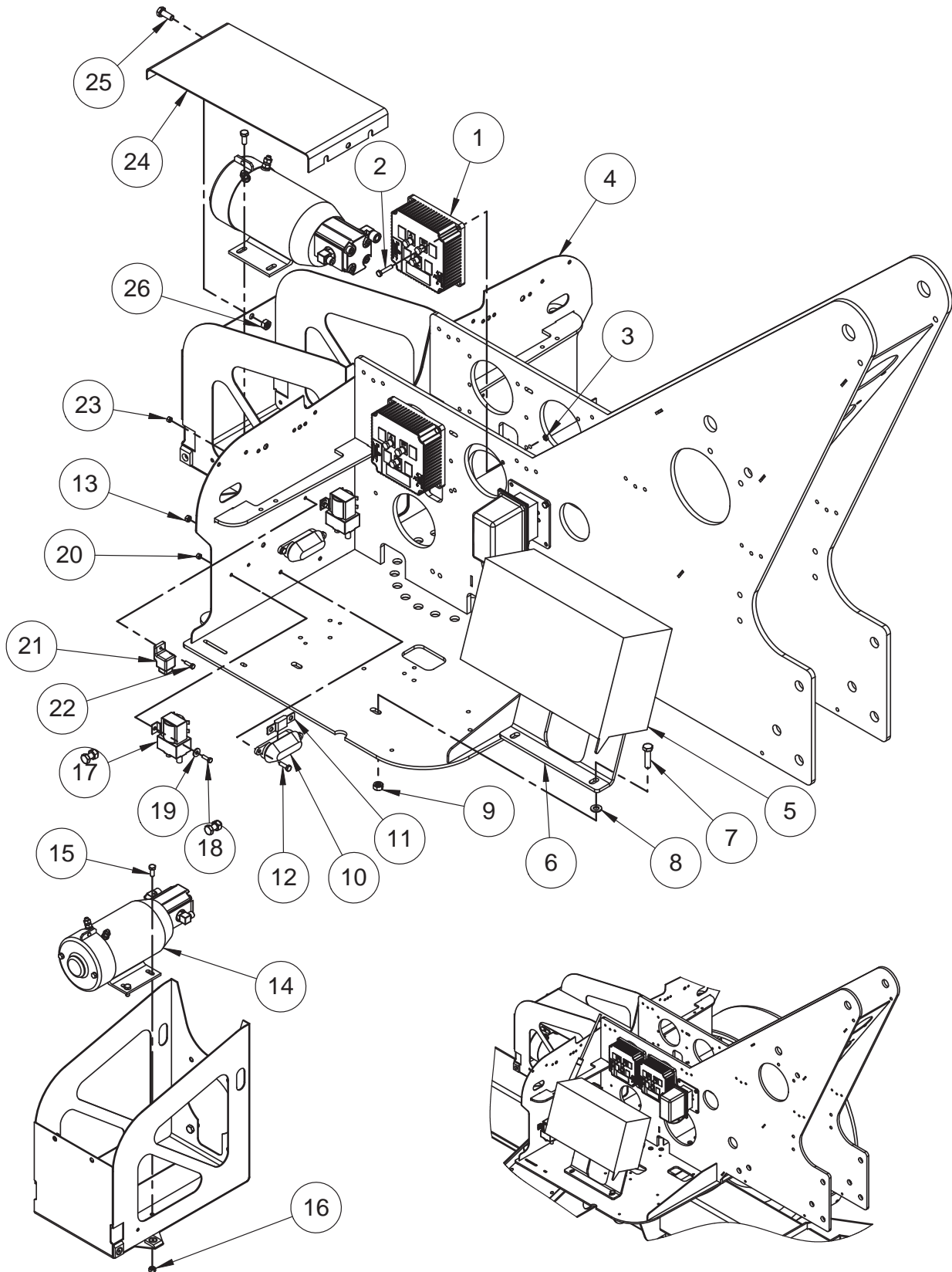

CONTROL COMPARTMENT ASSEMBLY FOR DRIVE & SET OPTION

ITEM NO.	PART NUMBER	DESCRIPTION	QTY.
1	A-00297	Motor Controller Replaces A-00255 Effective 2008	2
2	0096-0131	Screw, Hex Head Cap - M6 x 30	8
3	0096-0039	Hex Nut with Nylon Insert, M6	8
4	A-00200	Turntable Weldment	Ref.
5	A-00238	Lower Control Box	1
5A	A-00082	Loop Back Plug	1
5B	B38-00-0001	Replacement Key - Not Shown	2
6	A-00233	Lower Control Mount	1
7	0096-0018	Screw, Hex Head Cap - M10 x 40	2
8	0096-0047	Washer, Nylon - M10	2
9	0096-0041	Hex Nut with Nylon Insert, M10	2
10	B01-10-0331	Fuse Holder	2
11	B01-10-0330	Fuse, 200 Amp	2
12	0096-0001	Screw, Hex Head Cap - M6 x 16	4
13	0096-0039	Hex Nut with Nylon Insert, M6	4
14	A-00235	Power Unit	1
15	0096-0010	Screw, Hex Head Cap - M8 x 20	4
16	0096-0040	Hex Nut with Nylon Insert - M8	4
17	B01-06-0058	Contact, 24 Volts DC	2
18	0096-0113	Screw, Hex Head Cap - M4 x 16	4
19	0096-0061	Washer, Flat - M4	8
20	0096-0073	Hex Nut with Nylon Insert, M4	4
21	B01-06-0053	Relay, 24 Volts DC 20 Amp with Mounting Bracket	1
22	0096-0125	Screw, Hex Head Cap - M5 x 16	2
23	0096-0126	Hex Nut with Nylon Insert, M5	2
24	A-00256	Motor Cover	1
25	0096-0016	Screw, Hex Head Cap - M10 x 25	2
26	0096-0041	Hex Nut with Nylon Insert, M10	2

GROUND (LOWER) CONTROL BOX

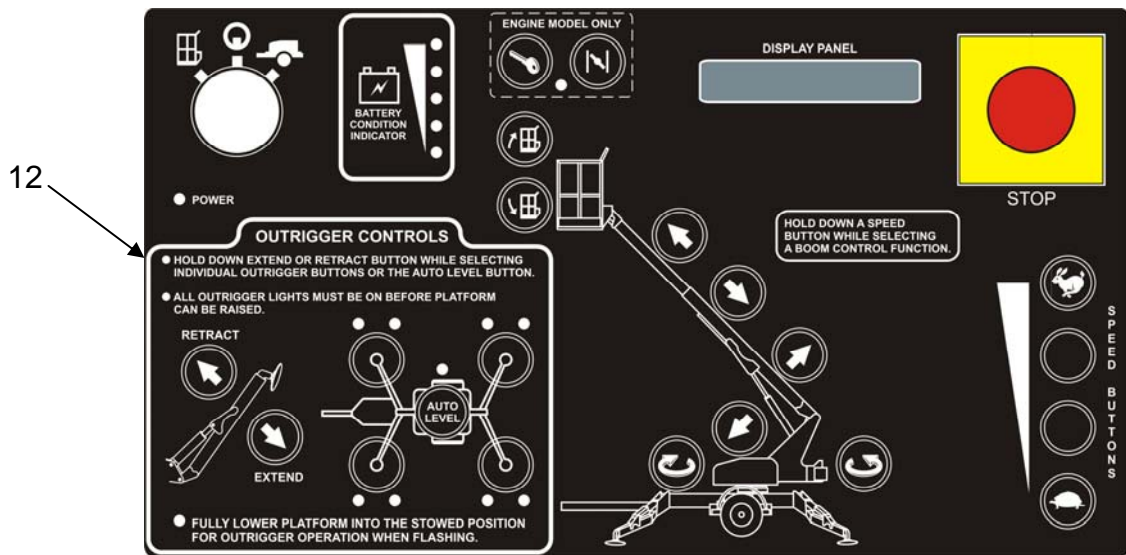
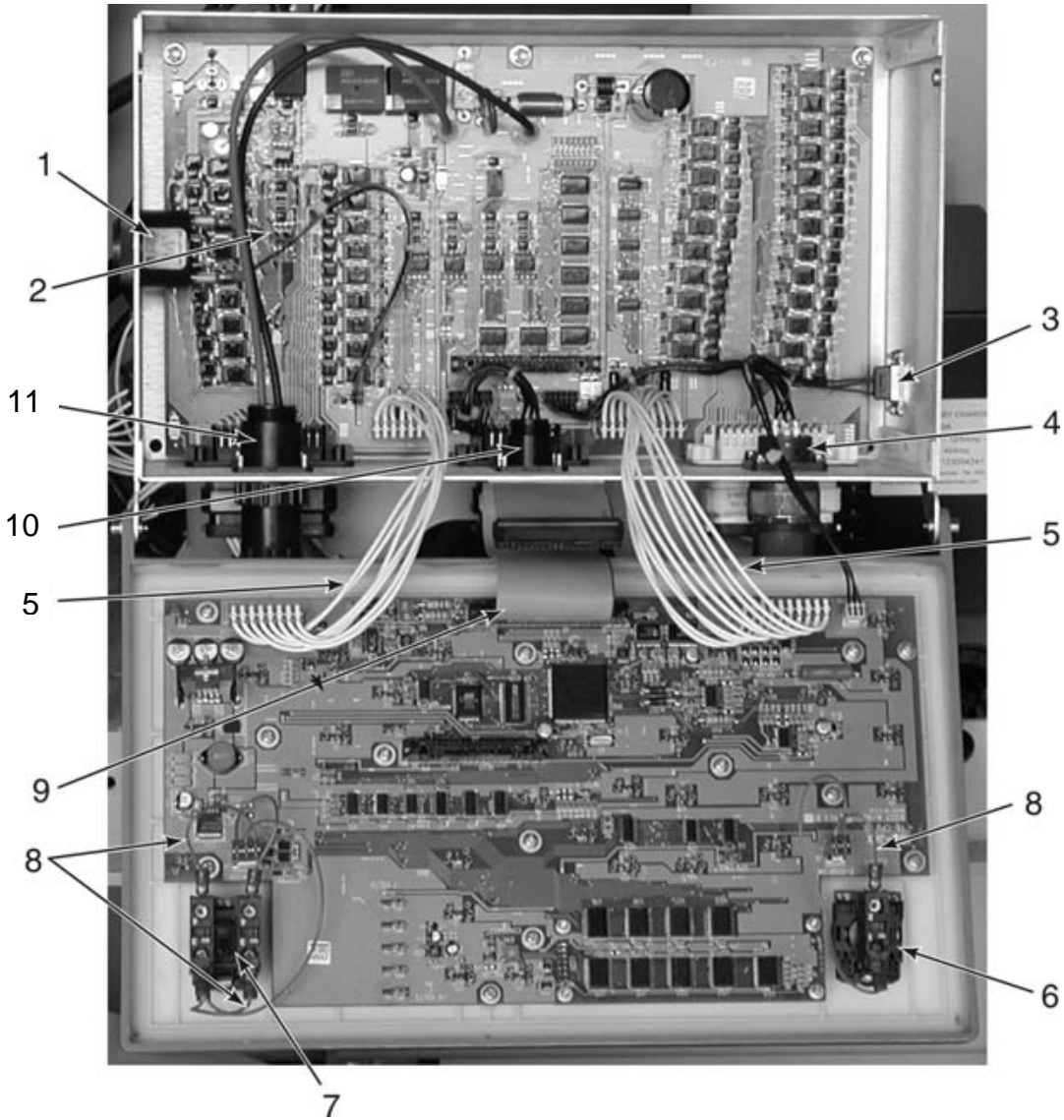

GROUND (LOWER) CONTROL BOX

ITEM NO.	PART NUMBER	DESCRIPTION	QTY.
	A-00238	Ground (Lower) Control Box Complete	1
	A-00238-B	Ground (Lower) Control Box Only	1
1	B01-10-0194	Alarm	1
2	B01-01-0147	Wiring Harness, Alarm	1
3	B01-01-0152	Wiring Harness, DB9	1
4	B01-01-0145	Wiring Harness, Communication	1
5	B01-01-0149	Wiring Harness, MTA	2
6	B01-02-0119	Emergency Stop Button with Contact and Mount	1
7	B01-02-0118	Key Switch, 3 Position	1
8	B01-01-0150	Wiring Harness, Key Switch and Emergency Stop	1
9	B01-01-0151	Ribbon Cable	1
10	B01-01-0146	Wiring Harness, Communication	1
11	B01-01-0148	Wiring Harness, Power	1
12	A-00238-D	Decal, Ground (Lower) Control Box Overlay	1
12A	A-00238-L	Lid with Decal Only – Not Shown	1
13	B01-10-0342	Switch Activating Disk - Not Shown	21
14	B01-10-0400	Standoff, Circuit Board – Not Shown	17
15	B38-00-0001	Replacement Key - Not Shown	1
16	B01-10-0335	CPU Board - Attached to Lid	1
17	B01-10-0336	Driver Board – Attached to Box	1

POWER UNIT COMPARTMENT ASSEMBLY

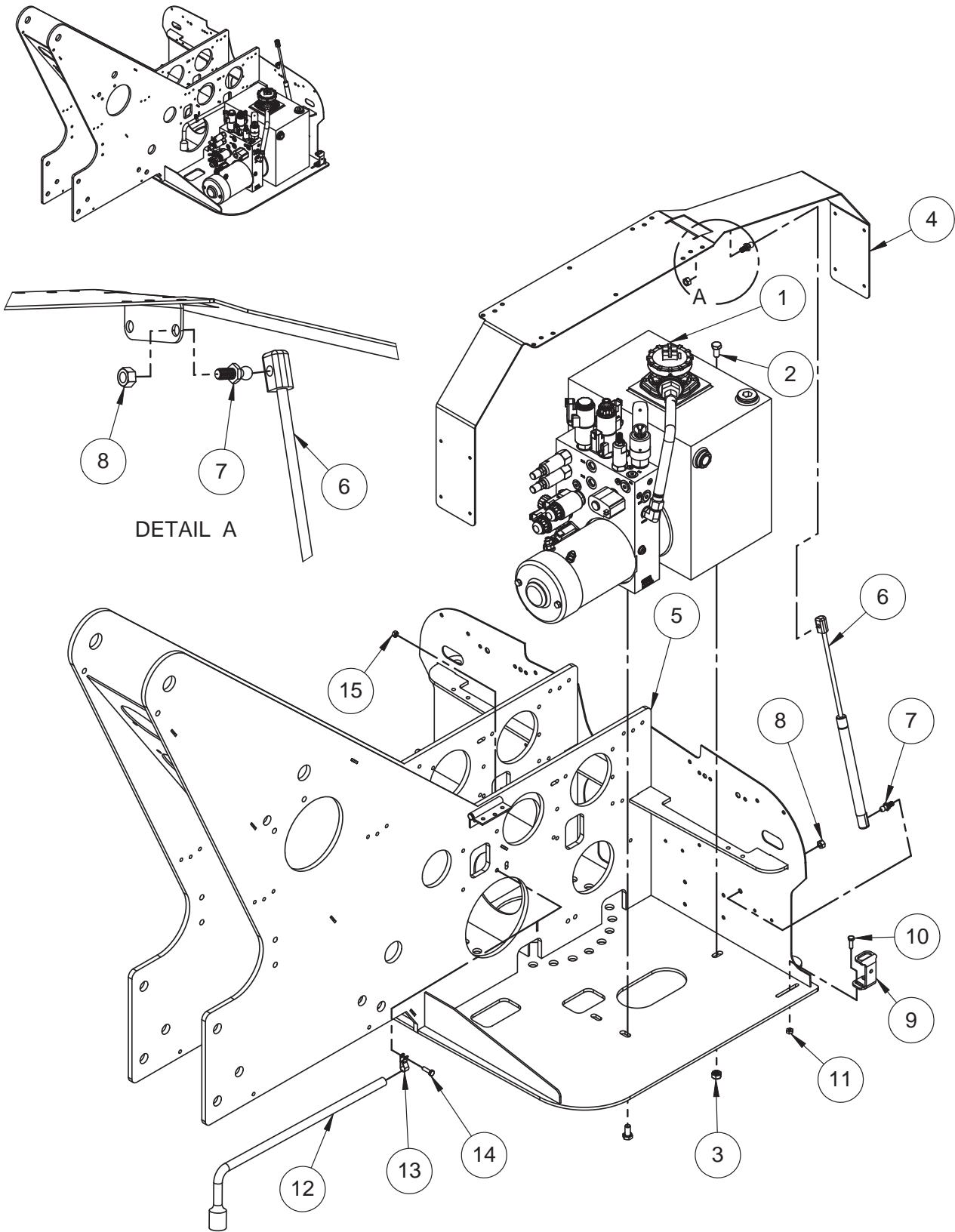

POWER UNIT COMPARTMENT ASSEMBLY

ITEM NO.	PART NUMBER	DESCRIPTION	QTY.
1	A-00254HS	Hydraulic Power Unit	1
2	0096-0014	Screw, Hex Head Cap - M10 x 20	3
3	0096-0041	Hex Nut with Nylon Insert - M10	1
4	A-00228	Cover Brace	1
5	A-00200	Turntable Weldment	Ref.
6	A-00274	Gas Spring	1
7	0090-0920	Ball Stud, 10MM	2
8	0090-0185	Hex Nut with Nylon Insert, 5/16-18	2
9	A-00290	Cover Stop Bracket	1
10	0096-0002	Screw, Hex Head Cap - M6 x 20	2
11	0096-0039	Hex Nut with Nylon Insert, M6	2
12	A-00268	Tire Iron / Jack Handle	1
13	B04-07-0033	Clamp	1
14	0096-0002	Screw, Hex Head Cap - M6 x 20	1
15	0096-0039	Hex Nut with Nylon Insert, M6	1

POWER UNIT COMPONENTS

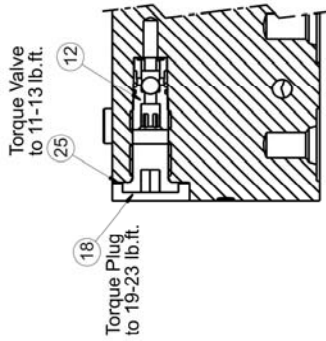

SECTION A-A

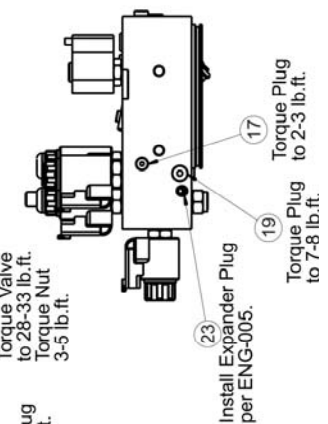
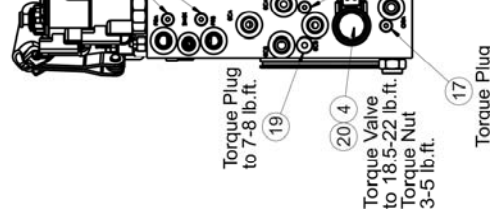
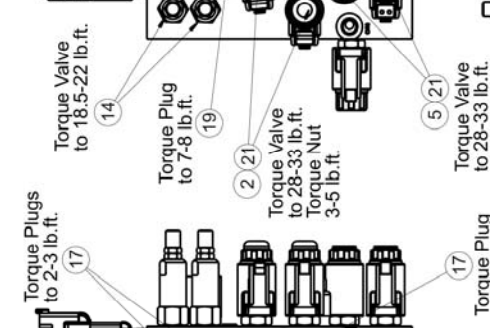
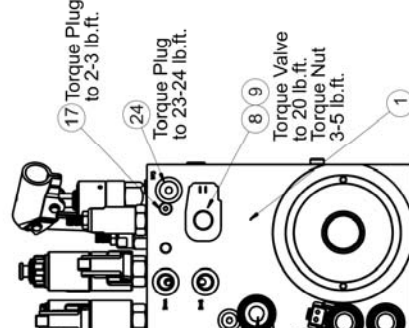
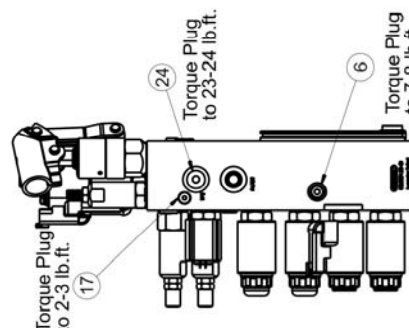
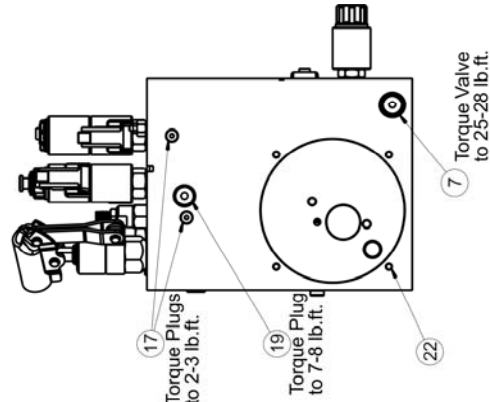
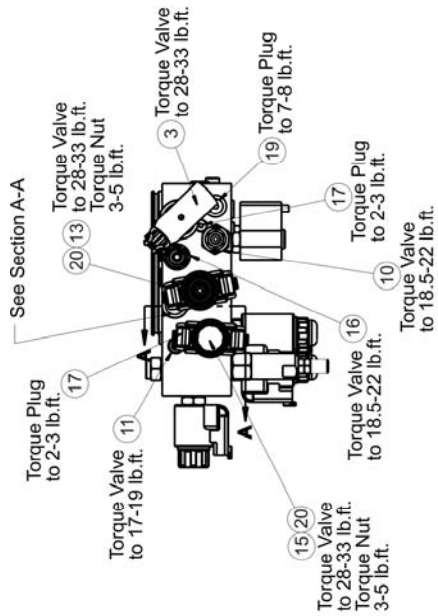

POWER UNIT COMPONENTS

ITEM NO.	PART NUMBER	DESCRIPTION	QTY.
1	B02-15-0496	Manifold, Valve Housing	1
2	B02-14-0108	Valve, Counterbalance	2
3	B02-15-0472	Manual Pump, Extend / Retract / Rotate	1
4	B02-14-0089	Valve, Cartridge - Outrigger Check	1
5	B02-14-0109	Valve, Cartridge - Outrigger	2
6	B02-14-0091	Valve, Check	1
7	B02-14-0110	Valve, Check	1
8	B02-14-0094L	Valve, Proportional	1
9	B02-14-0095	Coil Sterling, Proportional Valve	1
10	B02-14-0111	Valve, Relief	1
11	B02-14-0097	Valve, Relief	1
12	B02-14-0098	Valve, Shuttle	1
13	B02-14-0099	Valve, Cartridge - Rotator	1
14	B02-14-0100	Valve, Counterbalance	1
15	B02-14-0101	Valve, Cartridge - Basket Compensate	2
16	B02-14-0114	Valve, Flow Control - Rotator	1
17	B02-02-0245	Fitting, Plug - #2 ORB	11
18	B02-02-0246	Fitting, Hex Plug	1
19	B02-02-0248	Fitting, Plug - #4 ORB	5
20	B02-14-0112	Coil, 20 VDC - #8	5
21	B02-14-0113	Coil, 20 VDC - #10	5
22	B02-15-0497	Stud, #1/4-20 x 5/8	4
23	B02-15-0498	Expansion Plug	1
24	B02-02-0235	Fitting, Plug - #6 ORB	2
25	B02-15-0478	Seal Ring	1

POWER UNIT COMPONENTS (CONTINUED)

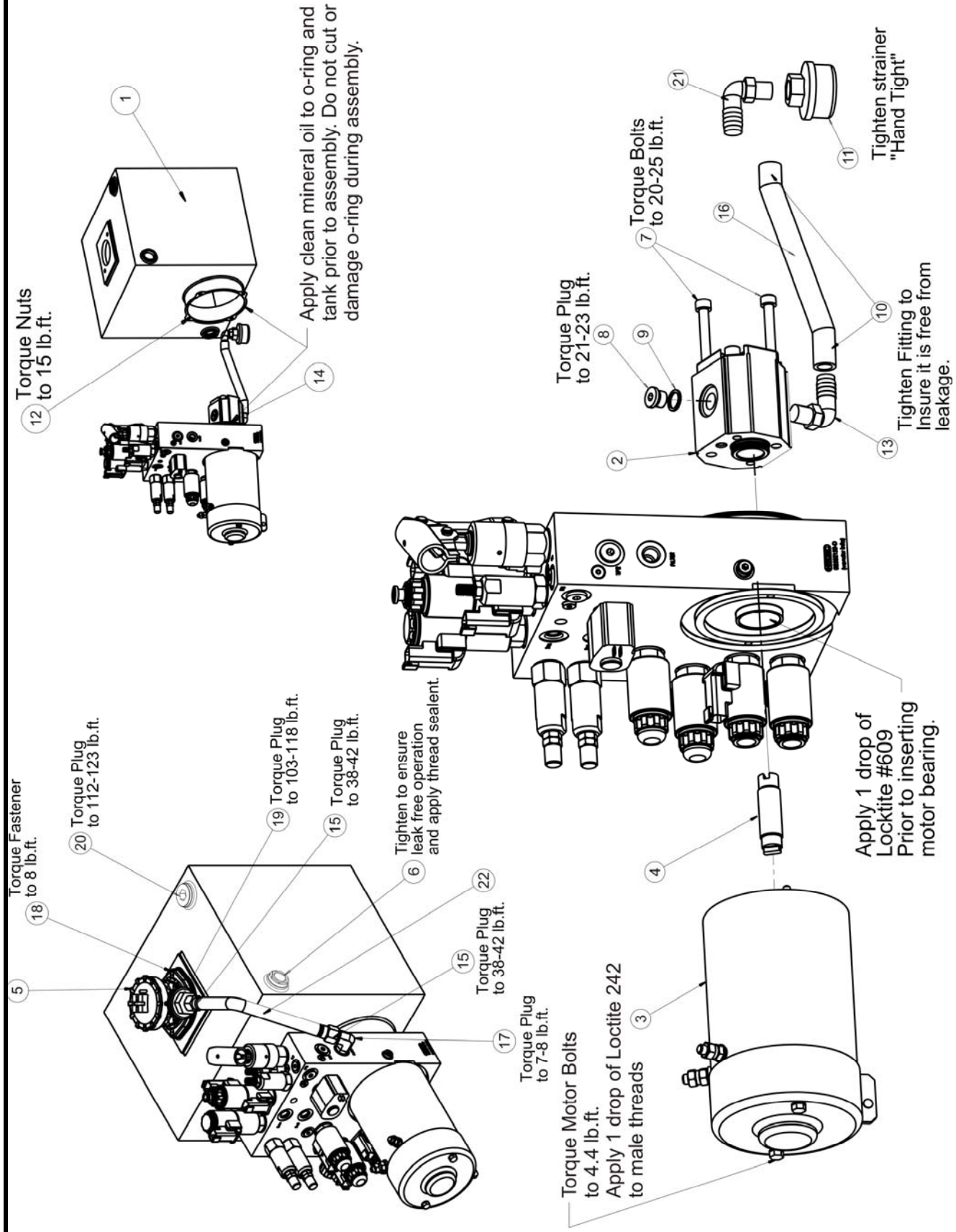

POWER UNIT COMPONENTS (CONTINUED)

ITEM NO.	PART NUMBER	DESCRIPTION	QTY.
1	B02-15-0513	Reservoir	1
2	B02-15-0470	Pump Assembly, 2.09 CCM	1
3	B02-15-0471	Motor, Pump - 24 V DC	1
4	B02-15-0500	Coupling, .875 x 2.795	1
5	B02-15-0501	Filter, Hydraulic	1
5A	B02-00-0070	Filter Only - Replacement	1
5B	B02-15-0532	Cap & "O" Ring	
5C	B02-15-0533	"O" Ring only	
6	B02-15-0476	Sight Glass	1
7	B02-15-0477	Screw, Socket Head Cap - M8 x 85	2
8	B02-02-0247	Fitting, Plug - M14 x 1.5 x 5.8	1
9	B02-15-0478	Seal Ring	1
10	B02-15-0485	Clamp, Band - #10-16	2
11	B02-15-0480	Filter, Suction	1
12	B02-15-0504	Allen Nut, 1/4-20	4
13	B02-02-0255	Fitting, M18 x HB-90M x HB-90	1
14	B02-15-0503	O-Ring, 110.72 x 3.53 NBR 70 D	1
15	B02-02-0279	Fitting, JIC-8 x Push On FS x PO	2
16	B02-15-0505	Hose, Black - 1/2 x 6"	1
17	B02-02-0280	Fitting, JIC-8 x #6 M x M	1
18	B02-15-0506	Screw, Hex Head Cap - #5/16-18 x 1 1/4	2
19	B02-02-0283	Fitting, JIC-8 x G 3/4 M x M	1
20	B02-02-0281	Fitting, Plug - #12 ORB	2
21	B02-02-0282	Fitting, 3/8 NPT x 1/2 M x HB	1
22	B02-15-0507	Hose, Black - 1/2 x 15"	1
	B02-02-0276	Fitting, Plug - #8 ORB - Under Reservoir	1

COVER ASSEMBLY

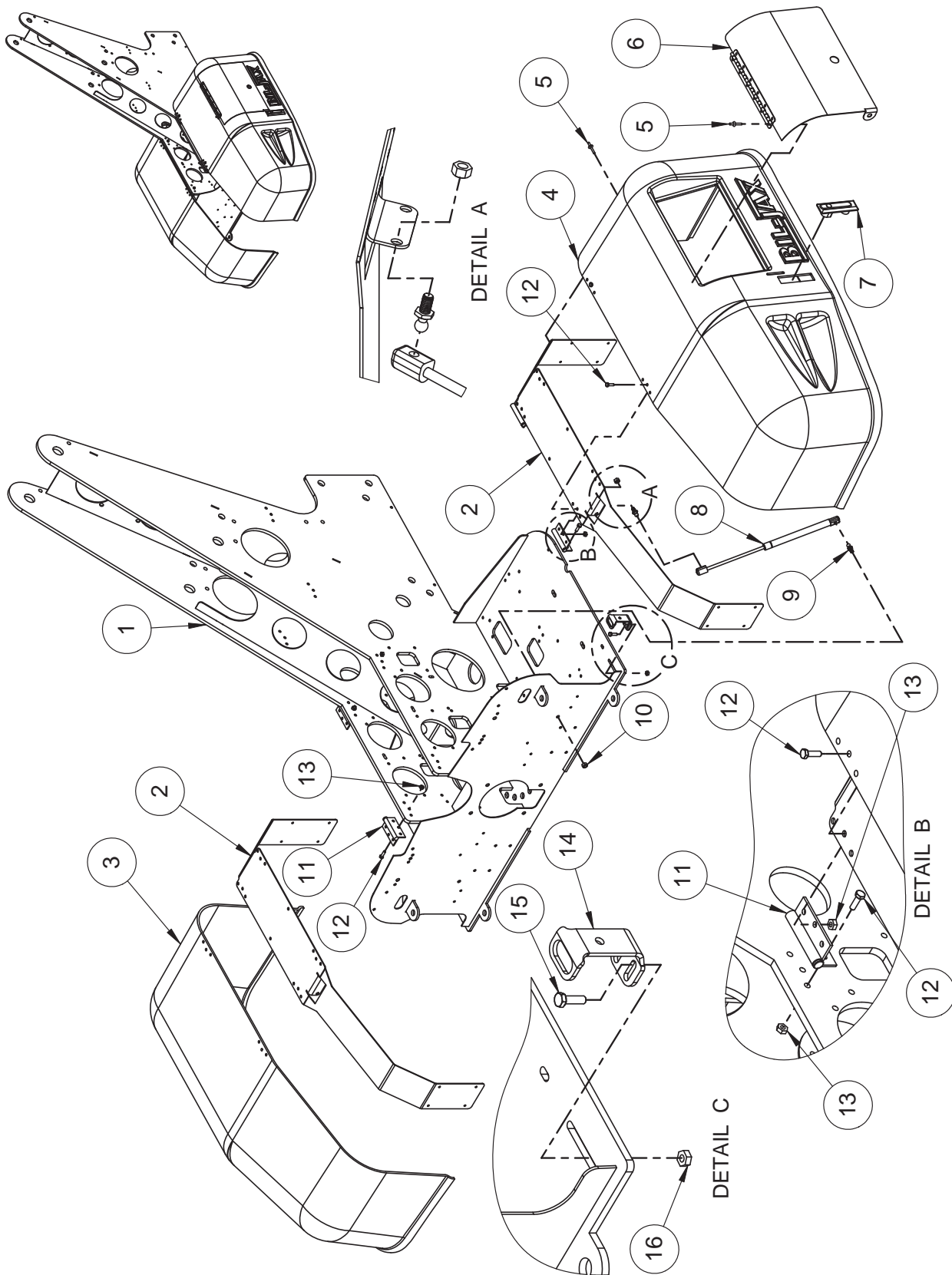

COVER ASSEMBLY

ITEM NO.	PART NUMBER	DESCRIPTION	QTY.
1	A-00200	Turntable Weldment	Ref.
2	A-00228	Cover Brace	2
3	A-00239	Cover, Right - Power Unit Replaces A03239 Effective 2007	1
4	A-00240	Cover, Left - Control Replaces A-03240 Effective 2007	1
5	0090-1080	Pop Rivet	22
6	A-00284	Controls Cover Weldment Replaces A-00258 Effective 2007	1
7	A-00292	Cover Latch Assembly Replaces A-00250 Effective 2007	2
7A	A-00293	Key - Not Shown	2
8	A-00274	Gas Spring	2
9	0090-0920	Ball Stud, 10MM	4
10	0090-0185	Hex Nut with Nylon Insert, 5/16-18	4
11	A-00252	Hinge	4
12	0096-0002	Screw, Hex Head Cap - M6 x 20	24
13	0096-0039	Hex Nut with Nylon Insert, M6	24
14	A-00290	Cover Stop Bracket	2
15	0096-0002	Screw, Hex Head Cap - M6 x 20	4
16	0096-0039	Hex Nut with Nylon Insert, M6	4

COUNTER WEIGHT ASSEMBLY

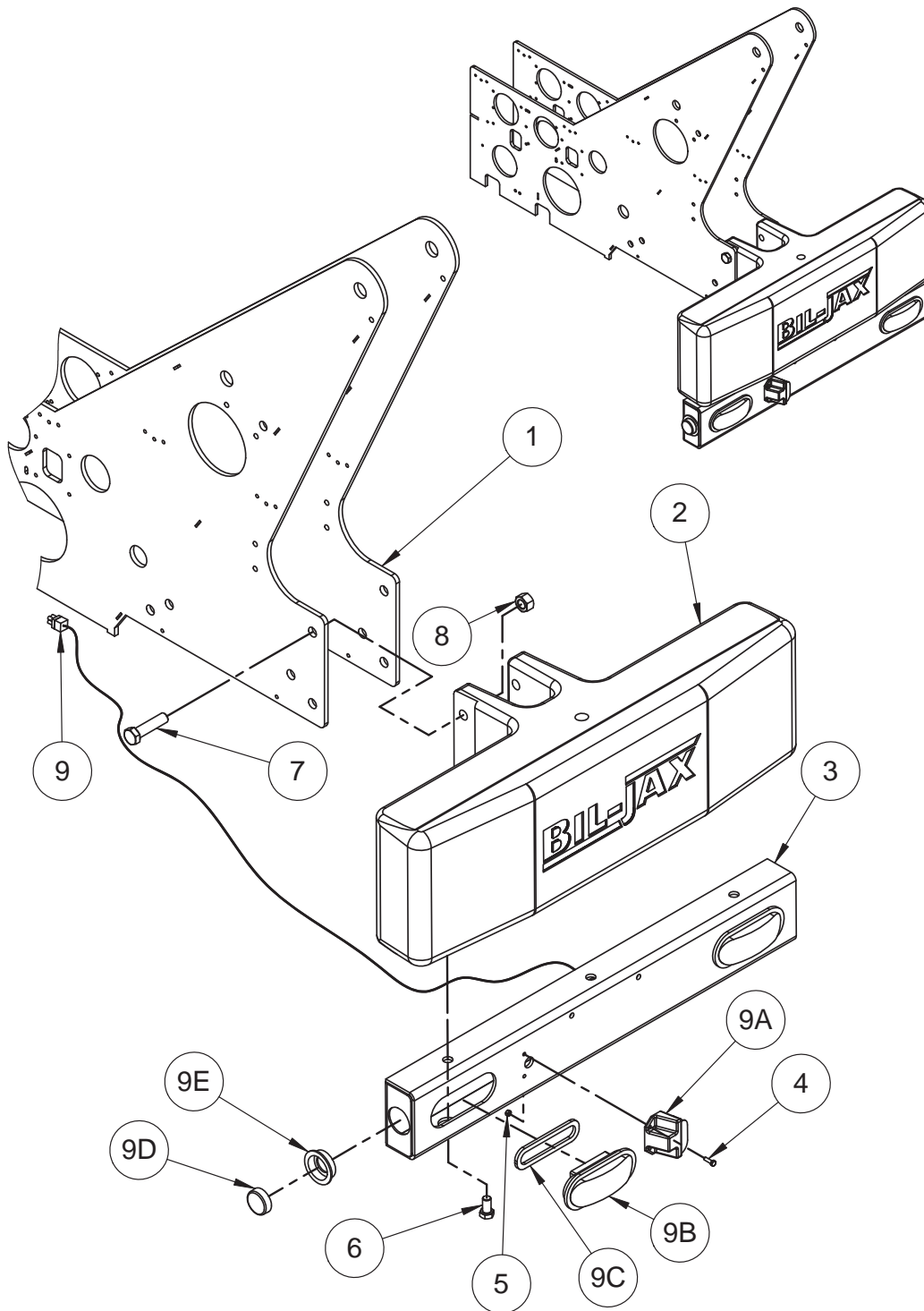

COUNTER WEIGHT ASSEMBLY

ITEM NO.	PART NUMBER	DESCRIPTION	QTY.
1	A-00200	Turntable Weldment	Ref.
2	A-00270	Counterweight	1
3	A-00285	Light Bracket Weldment	1
4	0096-0002	Screw, Hex Head Cap - M6 x 20	2
5	0096-0039	Hex Nut with Nylon Insert, M6	2
6	0096-0032	Screw, Hex Head Cap - M16 x 30	3
7	0096-0065	Screw, Hex Head Cap - M20 x 80	4
8	0096-0045	Hex Nut with Nylon Insert, M20	4
9	A-00210	Tail Light Kit	1
9A	B01-10-0240	License Plate Lamp	1
9B	B01-10-0235	Tail Light	2
9C	B01-10-0236	Grommet, Tail Light	2
9D	B01-10-0238	Marker Light, Red	2
9E	B01-10-0239	Grommet, Marker Light	2

BOOM ASSEMBLY

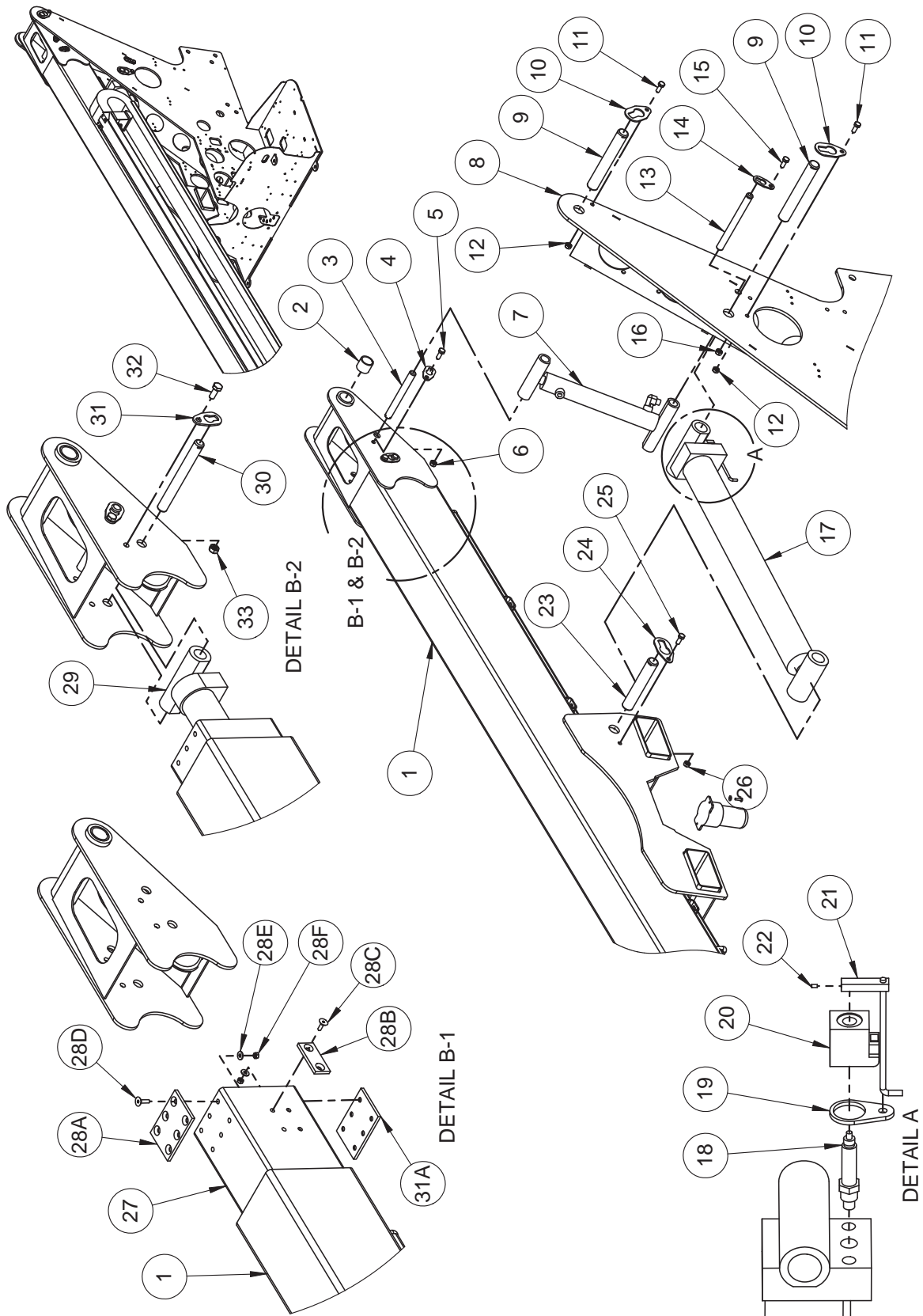

BOOM ASSEMBLY

ITEM NO.	PART NUMBER	DESCRIPTION	QTY.
1	A-00502	Telescopic Boom Weldment	1
2	A-00032	Composite Bearing, 1.25 x 1.50 x 1.25	2
3	A-00026	Pin, .75 x 7.0	1
4	A-00017	Pin Retainer, .75	1
5	0096-0016	Screw, Hex Head Cap - M10 x 25	1
6	0096-0041	Hex Nut with Nylon Insert, M10	1
7	A-00552	Hydraulic Master Cylinder	1
7A	B02-13-0130	Seal Kit	1
8	A-00200	Turntable Weldment	Ref.
9	A-00021	Pin, 1.25 x 8.5	2
10	A-00019	Pin Retainer, 1.25	4
11	0096-0016	Screw, Hex Head Cap - M10 x 25	4
12	0096-0041	Hex Nut with Nylon Insert, M10	4
13	A-00024	Pin, .75 x 8.5	1
14	A-00017	Pin Retainer, .75	1
15	0096-0016	Screw, Hex Head Cap - M10 x 25	1
16	0096-0041	Hex Nut with Nylon Insert, M10	1
17	A-00551	Hydraulic Boom Cylinder	1
17A	B02-13-0128	Seal Kit	1
18	B02-04-0101	Valve, Lift Cylinder	1
19	A-00283	Emergency Lower Guide	1
20	B01-08-0019A	Coil, 20 VDC with Weather Pack	1
21	A-00280	Emergency Lower Handle	1
22	0090-1103	Set Screw, 8-32 x 1/4	1
23	A-00023	Pin, 1.25 x 7.25	1
24	A-00019	Pin Retainer, 1.25	1
25	0096-0016	Screw, Hex Head Cap - M10 x 25	1
26	0096-0041	Hex Nut with Nylon Insert, M10	1
27	A-00510	Aluminum Extension Tube	Ref.
28	B22-00-0070	Kit - Wear Pads - Inner	1
28A	A-00540	Wear Pad, Top Rear	2
28B	A-00541	Wear Pad, Side	2
28C	0096-0003	Screw, Flat Head Socket Cap - M6 x 20	4
28D	0096-0006	Screw, Flat Head Socket Cap - M6 x 25	8
28E	0096-0077	Flat Washer, M6	12
28F	0096-0039	Hex Nut with Nylon Insert, M6	12
28G	B33-04-0024	Instructions - Inner Wear Pad Installation - Not Shown	1
29	A-00550	Extension Cylinder	Ref.
29A	B02-13-0132	Seal Kit	1
30	A-00026	Pin, .75 x 7.0	1
31	A-00017	Pin Retainer, .75	1
32	0096-0016	Screw, Hex Head Cap - M10 x 25	1
33	0096-0041	Hex Nut with Nylon Insert, M10	1

BOOM ASSEMBLY (CONTINUED)

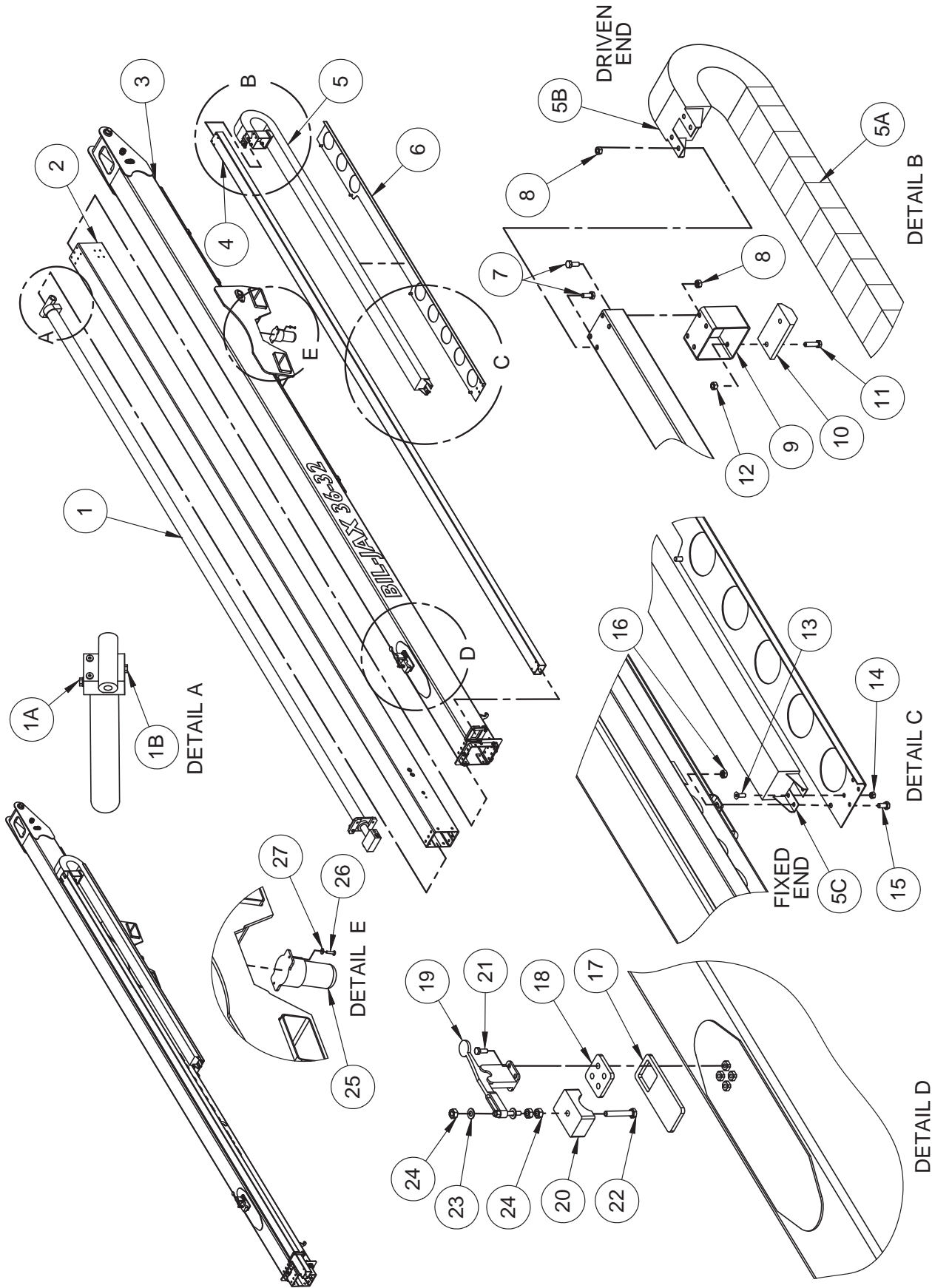

BOOM ASSEMBLY (CONTINUED)

ITEM NO.	PART NUMBER	DESCRIPTION	QTY.
1	A-00550	Extension Cylinder	1
1A	B02-04-0106	1500 PSI Counter Balance Valve	1
1B	B02-04-0105	2500 PSI Counter Balance Valve	1
1C	B02-13-0132	Seal Kit	1
2	A-00510	Telescopic Boom Tube (Aluminum)	1
3	A-00502	Telescopic Boom Weldment	1
4	A-00531	Slide Tube	1
5	A-00520	Cable Track, Single Piece Mounting, Replaces B00-00-0031 Cable Track-41 Links Effective 2010	1
5A	B00-00-0178	Individual Link For A-00520 Replaces B00-00-0074 Effective 2010	1
5B	B00-00-0179	Bracket, Cable Trak - Fixed End - Effective 2010 Replaces B29-00-0166-1 Left Hand B29-00-0166-2 Right Hand	1
5C	B00-00-0180	Bracket, Cable Trak - Driven End - Effective 2010 Replaces B29-00-0165-1 Left Hand B29-00-0165-2 Right Hand	1
6	A-00536	Cable Track Tray	1
7	0096-0010	Screw, Hex Head Cap - M8 x 20	8
8	0096-0040	Hex Nut with Nylon Insert, M8	8
9	A-00538	Cable Support Tube	1
10	A-00539	Cable Slide Block	1
11	0096-0056	Screw, Hex Head Cap - M8 x 30	2
12	0096-0040	Hex Nut with Nylon Insert, M8	2
13	0096-0012	Screw, Flat Head Socket Cap - M8 x 25	4
14	0096-0040	Hex Nut with Nylon Insert, M8	4
15	0096-0014	Screw, Hex Head Cap - M10 x 20	4
16	0096-0041	Hex Nut with Nylon Insert, M10	4
17	A-00470	Cage Storage Pad	1
18	A-00471	Cage Latch Plate	1
19	A-00473	Cage Latch	1
20	A-00469	Cage Latch Pad	1
21	0096-0001	Screw, Hex Head Cap - M6 x 16	4
22	0096-0053	Screw, Hex Head Cap - M8 x 50 Replaces 0096-0049 Effective 2008	1
23	0096-0104	Flat Washer, M8	2
24	0096-0040	Hex Nut with Nylon Insert, M8	4
25	A-00289	Strobe Light Assembly (Option)	1
25A	B01-10-0275	Strobe Light	1
25B	B01-09-0092	Connector Assembly - 2 Female - W/P - Not Shown	1
25C	B01-09-0119	Terminal - Female - W/P - 12/14 gage - Not Shown	2
25D	B01-09-0093	Seal - Wire - W/P - 16/18 gage - Green - Not Shown	2
26	0096-0236	Screw, Round Head Machine - 10-24 x 3/4	2
27	0090-0415	Flat Washer, #10	2

BOOM ASSEMBLY (CONTINUED)

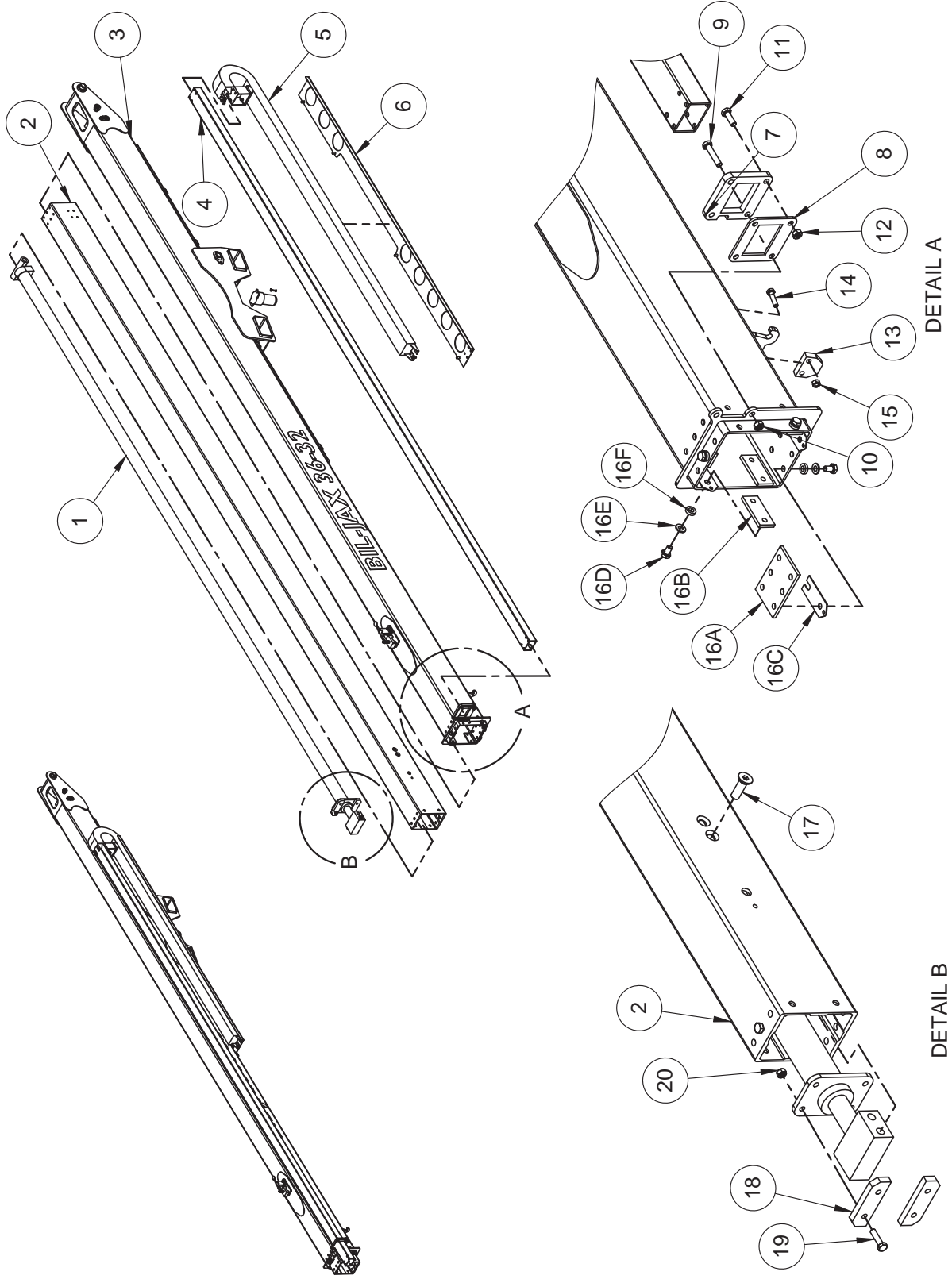

BOOM ASSEMBLY (CONTINUED)

ITEM NO.	PART NUMBER	DESCRIPTION	QTY.
1	A-00550	Extension Cylinder	Ref.
2	A-00510	Telescopic Boom Tube (Aluminum)	Ref.
3	A-00502	Telescopic Boom Weldment	Ref.
4	A-00531	Slide Tube	Ref.
5	A-00520	Cable Track, Single Piece Mounting, Replaces B00-00-0031 Effective 2010	Ref.
6	A-00536	Cable Track Tray	Ref.
7	A-00529	Tube Slider Back	1
8	A-00532	Tube Slider	1
9	0096-0018	Screw, Hex Head Cap - M10 x 40	2
10	0096-0041	Hex Nut with Nylon Insert, M10	2
11	0096-0017	Screw, Hex Head Cap - M10 x 30	2
12	0096-0041	Hex Nut with Nylon Insert, M10	2
13	A-00537	Boom Switch Block	1
14	0096-0098	Screw, Hex Head Cap - M8 x 35	2
15	0096-0040	Hex Nut with Nylon Insert, M8	2
16	B22-00-0069	Kit - Wear Pads - Outer	1
16A	A-00542	Wear Pad Front Bottom	1
16B	A-00533-2	Wear Pad Boom - Gray	5
16C	A-00534	Wear Pad Shim	2-4
16D	0096-0132	Screw, Hex Head Cap - M10 x 16 (Aluminum) Replaces 0096-0013 Effective 2008	14
16E	0096-0119	Flat Washer, M10	14
16F	0096-0047	Washer, Nylon - M10	14
17	0096-0033	Screw, Flat Head Socket Cap - M16 x 35	4
18	A-00535	Slider, Extension Cylinder	2
19	0096-0017	Screw, Hex Head Cap - M10 x 30	4
20	0096-0041	Hex Nut with Nylon Insert, M10	4
21	A-00940	Tire Mount Kit - Spare Tire (Option) - Not Shown	1

PLATFORM MOUNT ASSEMBLY

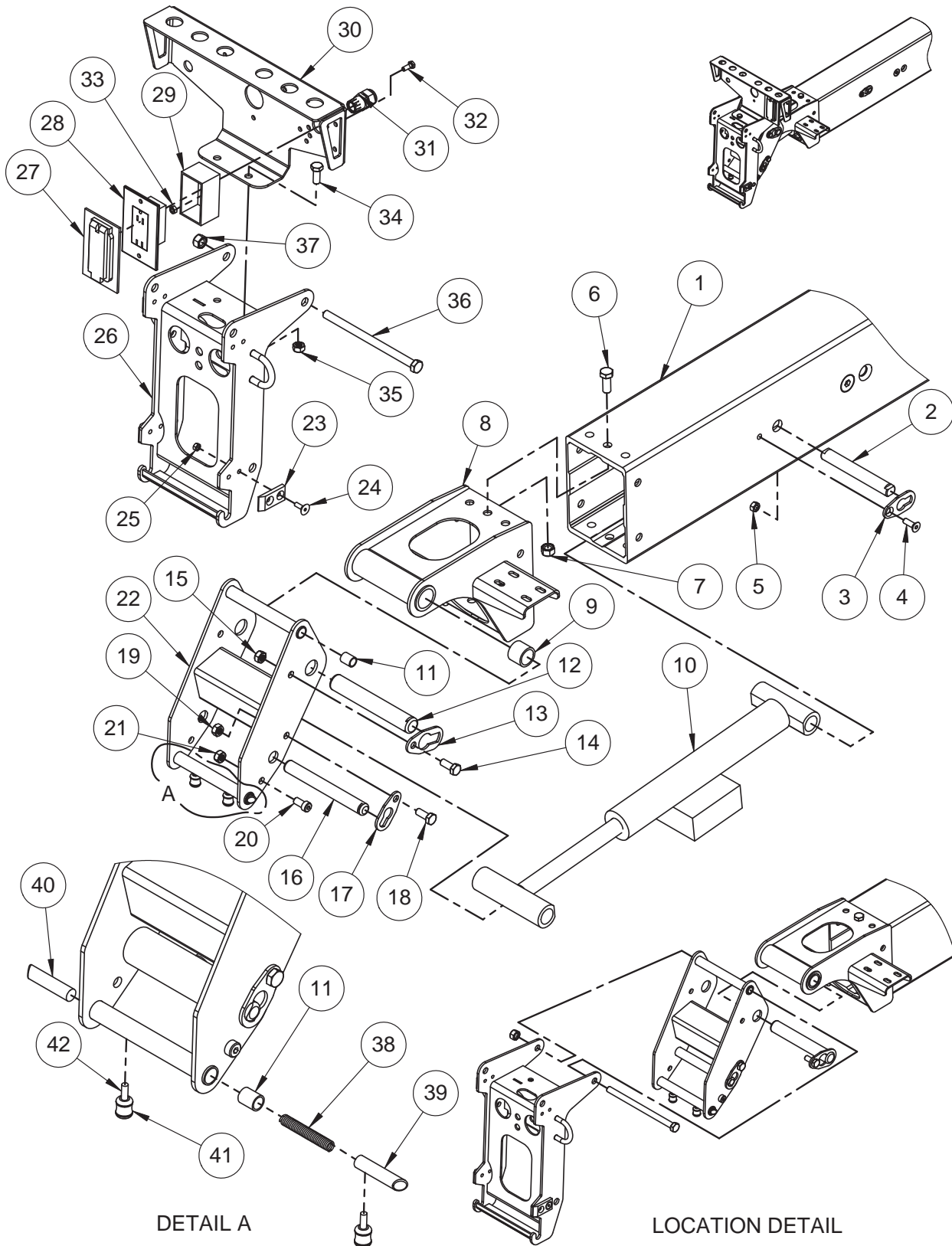

PLATFORM MOUNT ASSEMBLY

ITEM NO.	PART NUMBER	DESCRIPTION	QTY.
1	A-00510	Telescopic Boom Tube (Aluminum)	Ref.
2	A-00027	Pin, .75 x 5.25	1
3	A-00034	Pin Retainer, .75 - Flat Head	1
4	0096-0012	Screw, Flat Head Cap - M8 x 25	1
5	0096-0040	Lock Nut M8	1
6	0096-0020	Screw, Hex Head Cap - M12 x 30	10
7	0096-0042	Hex Nut with Nylon Insert, M12	10
8	A-00522	Boom End Weldment	1
9	A-00031	Bearing, Composite - 1.00 x 1.25 x 1.00	2
10	A-00553	Slave Cylinder	1
10A	B02-13-0131	Seal Kit	1
10B	B02-04-0095	Valve, Counter Balance - CABG-LHN	2
11	A-00033	Bearing, Composite - .50 x .625 x .75	4
12	A-00025	Pin, 1.0 x 6.5	1
13	A-00018	Pin Retainer. 1.0	1
14	0096-0016	Screw, Hex Head Cap - M10 x 25	1
15	0096-0041	Hex Nut with Nylon Insert, M10	1
16	A-00035	Pin, .75 x 6.5	1
17	A-00017	Pin Retainer, .75	1
18	0096-0016	Screw, Hex Head Cap - M10 x 25	1
19	0096-0041	Hex Nut with Nylon Insert, M10	1
20	0096-0015	Screw, Socket Head Cap - M10 x 20	2
21	0096-0041	Hex Nut with Nylon Insert, M10	2
22	A-00601	Platform Pivot Weldment	1
23	A-00038	Ramp	4
24	0096-0003	Screw, Flat Head Socket Cap - M6 x 20	8
25	0096-0039	Hex Nut with Nylon Insert, M6	8
26	A-00610	Platform Mount Weldment	1
27	B01-10-0392	Cover, GFI Receptacle Replaces B01-10-0035 Effective 2009	1
28	B01-10-0034	Receptacle - GFI	1
28A	A-00288	Plastic Cover	1
28B	0096-0002	Screw, Hex Head Cap - M6 x 20 - Not Shown	2
28C	0096-0039	Hex Nut with Nylon Insert, M6 - Not Shown	2
29	B01-10-0046	Outlet Box - Weather Tite	1
30	A-00979	Bulkhead Mount	1
31	B01-09-0029	Cord Grip, Plastic 1/2in	1
32	0096-0001	Screw, Hex Head Cap - M6 x 16	2
33	0096-0039	Hex Nut with Nylon Insert - M6	2
34	0096-0016	Screw, Hex Head Cap - M10 x 25	2
35	0096-0041	Hex Nut with Nylon Insert, M10	2
36	0096-0055	Screw, Hex Head Cap - M12 x 190	1

PLATFORM MOUNT ASSEMBLY (CONTINUED)

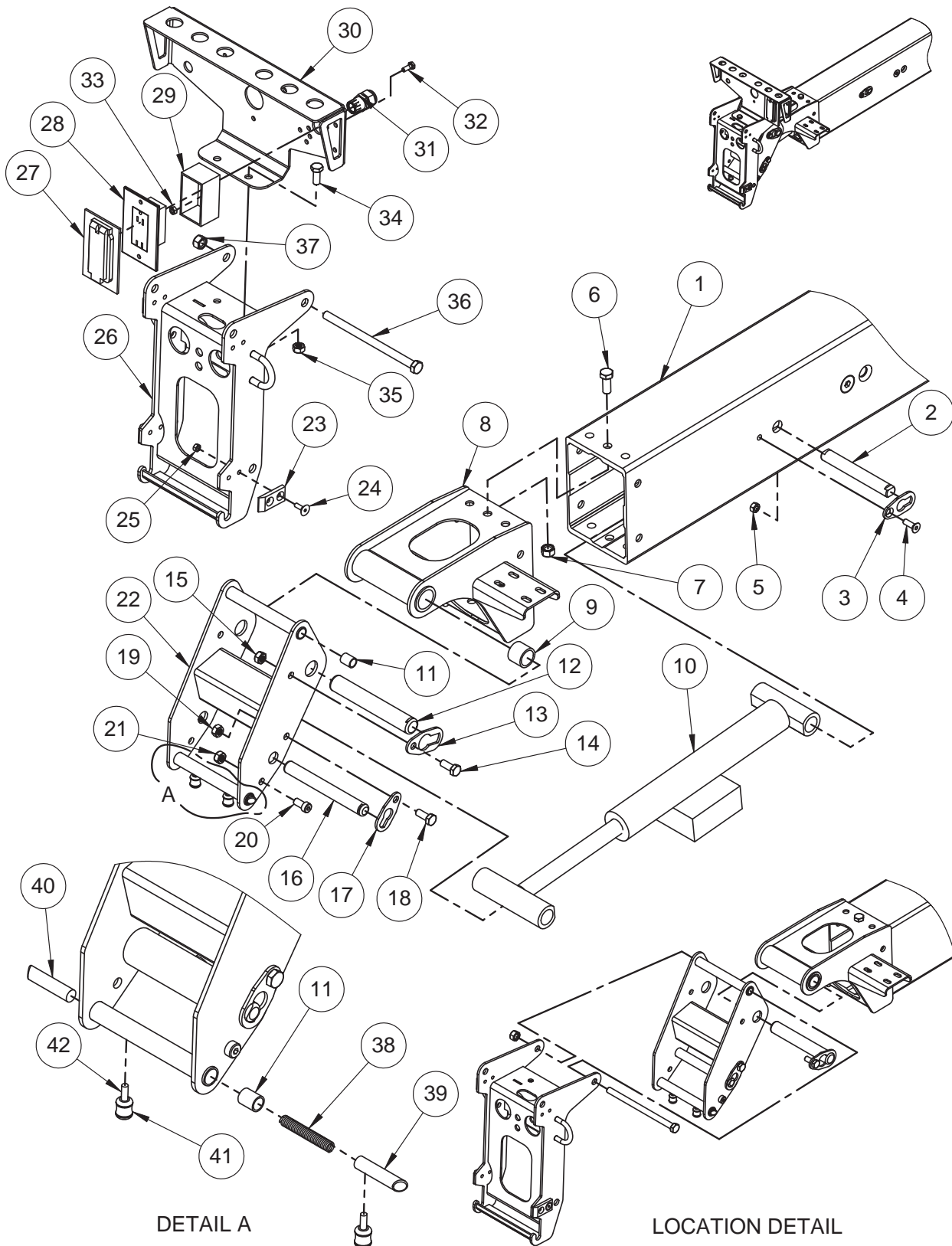

PLATFORM MOUNT ASSEMBLY (CONTINUED)

ITEM NO.	PART NUMBER	DESCRIPTION	QTY.
37	0096-0042	Hex Nut with Nylon Insert, M12	1
38	A-00608	Compression Spring	1
39	A-00606-L	Snap Pin, Left	1
40	A-00606-R	Snap Pin, Right	1
41	A-00609	Knob, Platform Latch	2
42	0090-1112	Roll Pin, 1/4 X 1.5	2

AC POWER HOOK-UP ASSEMBLY

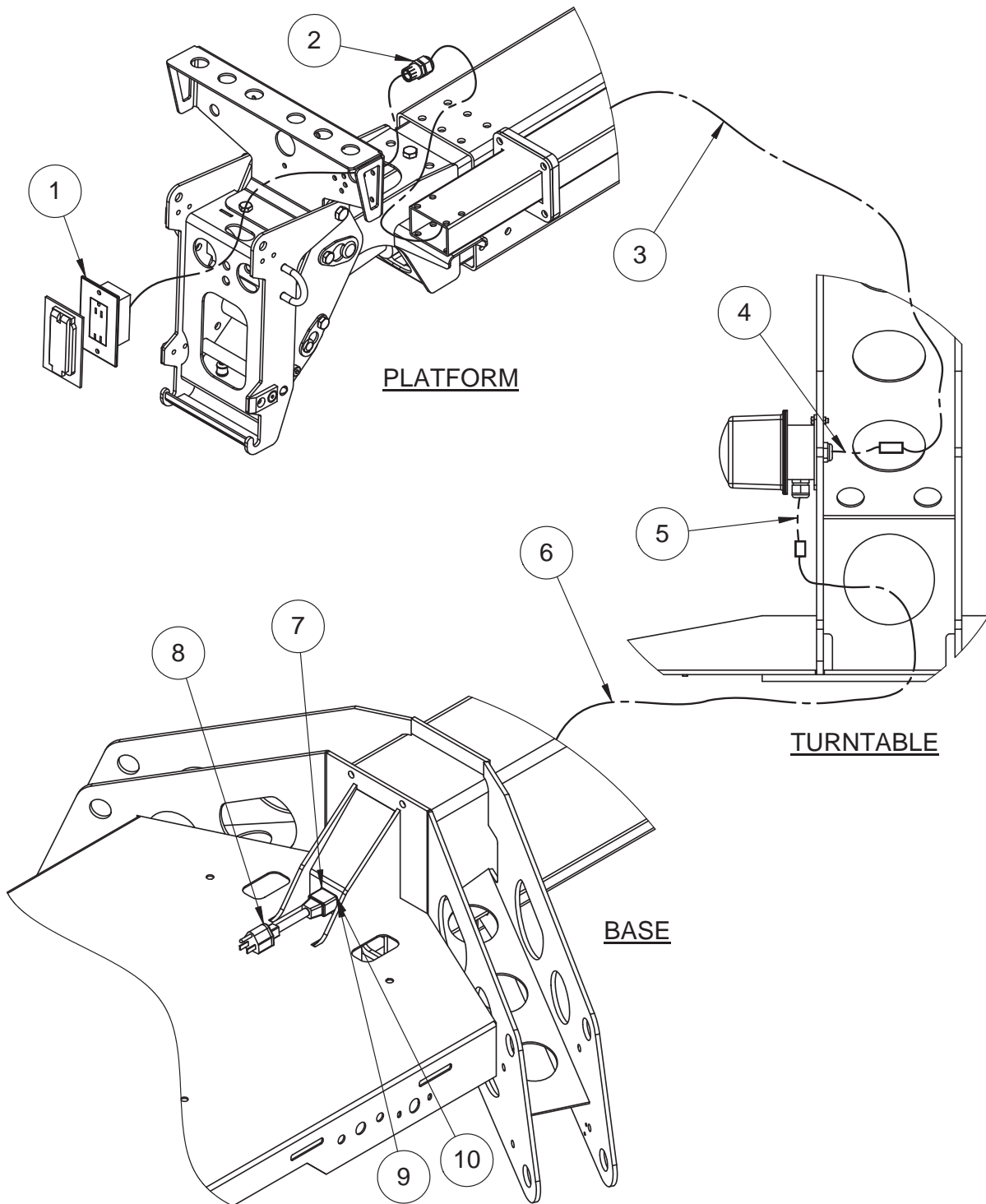

POWER HOOK-UP ASSEMBLY

ITEM NO.	PART NUMBER	DESCRIPTION	QTY.
1	B01-10-0046	Outlet Box	2
2	B01-09-0029	Cord Grip, Plastic 1/2in	3
3	A-00722	Harness, Wire AC - 110 Volt to Platform	1
4	B01-01-0195	Wire Assembly, GFI Box - Cage	1
5	B01-01-0194	Wire Assembly, GFI Box - Trailer	1
6	A-00944	Wire Assembly, 110 Volt	1
7	A-00178	Connector, 16/20 Amp	1
8	A-00179	Cord Assembly	1
9	A-00186	Lock, Connector	1
10	0090-1081	Screw, Pan Head Sheet Metal - # 4 x 3/4	2

PLATFORM ASSEMBLY

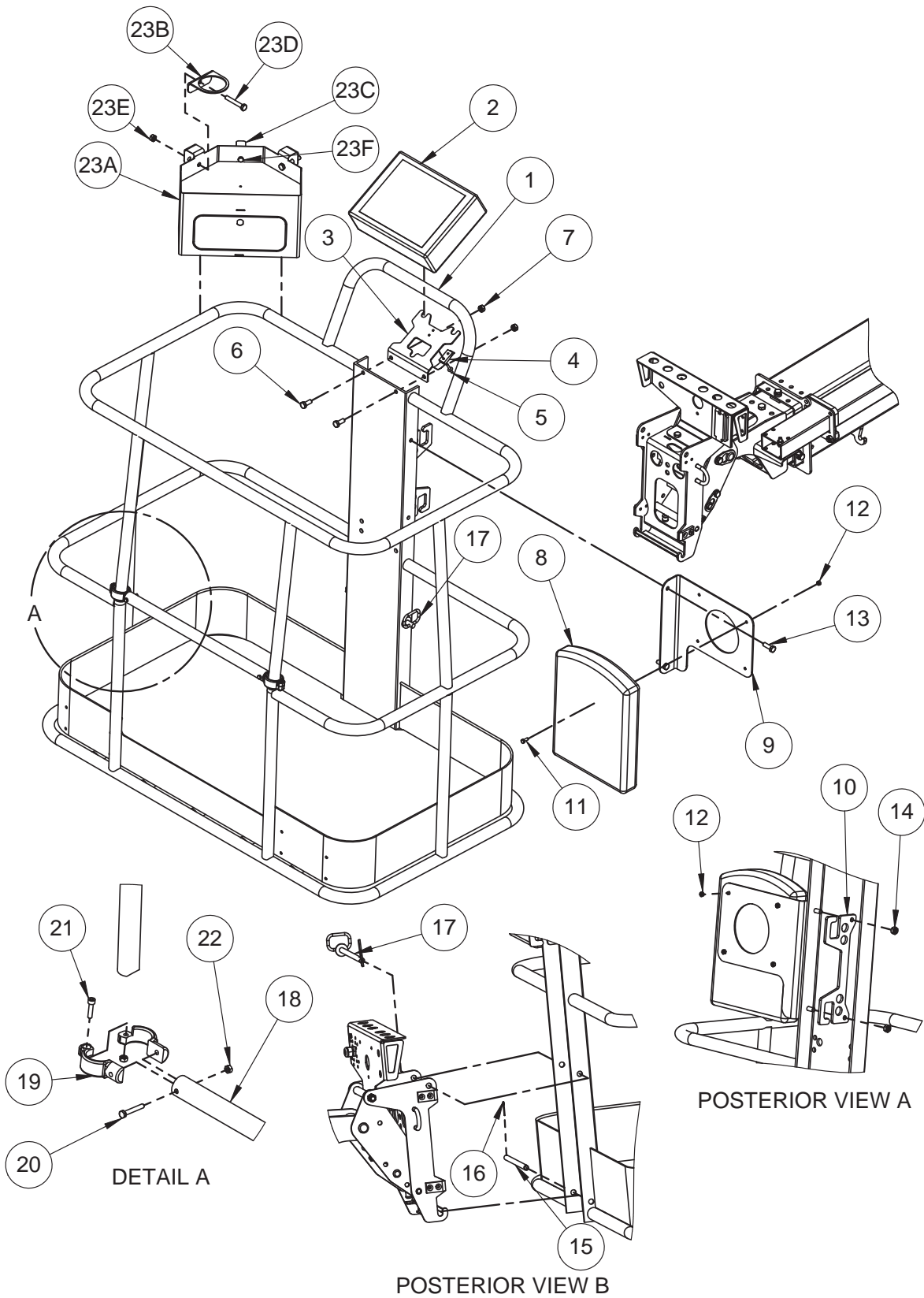

PLATFORM ASSEMBLY

ITEM NO.	PART NUMBER	DESCRIPTION	QTY.
	A-00449	Platform Assembly	1
1	A-00450	Platform Weldment	1
2	A-00465	Upper Control Box	1
2A	A-00931	Upper Control Box - Drive & Set (Option)	1
3	A-00461	Upper Control Box Mount	1
4	A-00466	Control Box Latch	1
5	0090-0679	Pop Rivet, 5/32 x .250	2
6	0096-0016	Screw, Hex Head Cap - M10 x 25	2
7	0096-0041	Hex Nut with Nylon Insert, M10	2
8	A-00475	Manual Storage Box	1
9	A-00468	Manual Mount Plate	1
10	A-00474	Cord Wrap Bracket	1
11	0096-0001	Screw, Hex Head Cap - M6 x 16	4
12	0096-0039	Hex Nut with Nylon Insert, M6	4
13	0096-0017	Screw, Hex Head Cap - M10 x 30	2
14	0096-0041	Hex Nut with Nylon Insert, M10	2
15	A-00071	Pin, 0.5" x 8.875"	1
16	0090-0147	Cotter Pin, 1/8 x 1 1/4	2
17	A-00028	Clevis Pin with Tension Lock	1
18	A-00464	Mid Rail Tube	1
19	A-00463	Mid Rail End	4
20	0096-0052	Screw, Hex Head Cap - M6 x 40	2
21	0096-0115	Screw, Socket Head Cap - M6 x 25	2
22	0096-0039	Hex Nut with Nylon Insert, M6	4
23	A-02600	Tool Box Assembly (Option)	1
23A	A-02601	Tool Box	1
23B	A-02609	Cup Holder	1
23C	A-02610	Rear Brace	1
23D	0096-0066	Hex Head Cap - M10 x 60	2
23E	0096-0041	Hex Nut with Nylon Insert - M10	2
23F	0096-0010	Screw, Hex Head Cap - M8 x 20	2
23G	0096-0040	Hex Nut with Nylon Insert - M8 - Not Shown	2
23H	B37-00-0006	Lock - Utility Cylinder Knob Style - Not Shown	1

PLATFORM (UPPER) CONTROL BOX

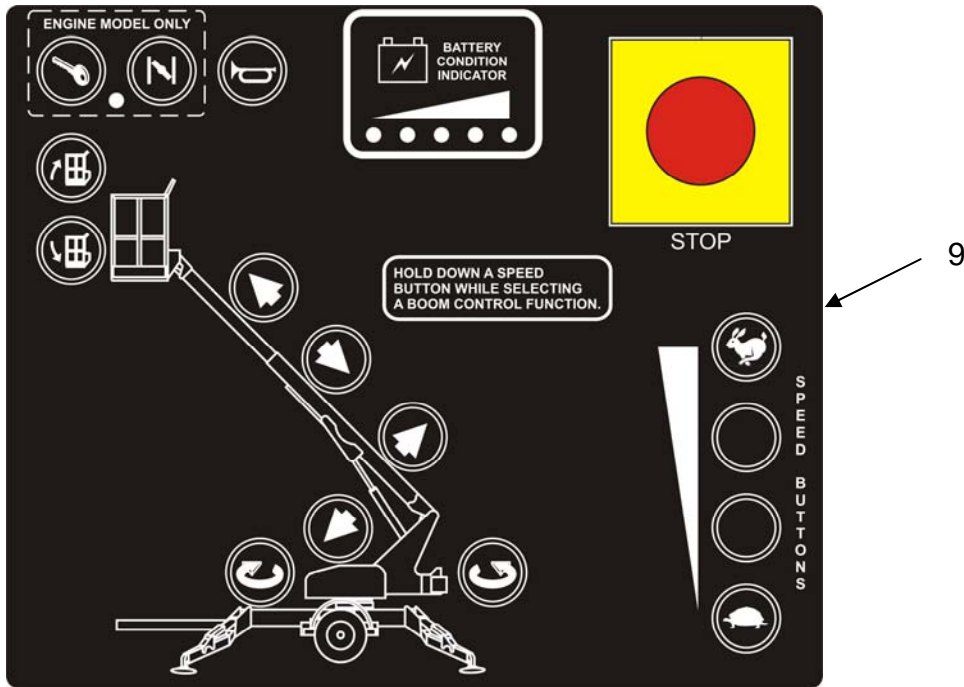
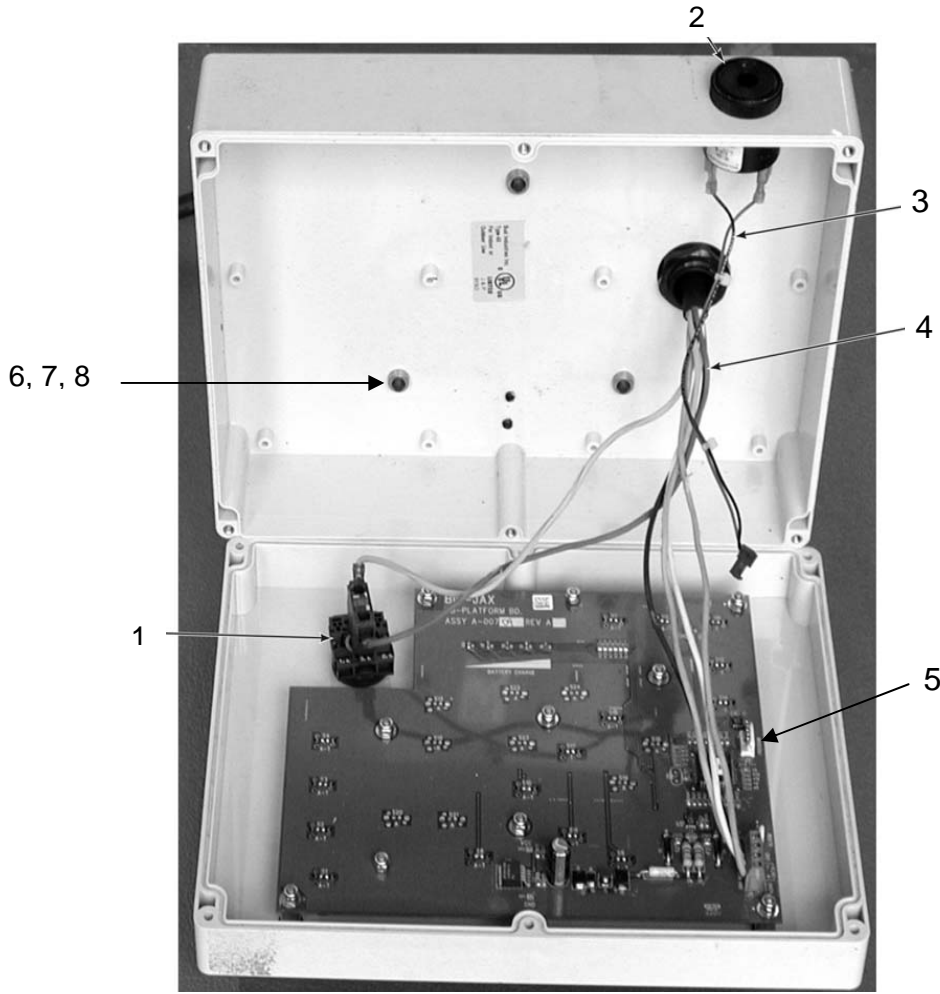

PLATFORM (UPPER) CONTROL BOX

ITEM NO.	PART NUMBER	DESCRIPTION	QTY.
	A-00465	Platform (Upper) Control Box	1
	A-00465-B	Platform (Upper) Control Box - Only	1
1	B01-02-0119	Emergency Stop Button with Contact and Mount	1
2	B01-10-0194	Alarm	1
3	B01-01-0153	Wiring Harness, Alarm	1
4	B01-01-0154	Wiring Harness, Tail, Upper Control Box	1
5	B01-10-0337	Circuit Board, Upper	1
6	A-00462	Spool - Now Shown	3
7	0096-0006	Screw, Flat Head Socket Cap - M6 x 25	3
8	0096-0039	Hex Nut with Nylon Insert - M6	3
9	A-00465-D	Decal, Platform (Upper) Control Box Overlay	1
10	B01-10-0341	Switch Activating Disk - Now Shown	15
11	B01-10-0400	Standoff, Circuit Board - Not Shown	10

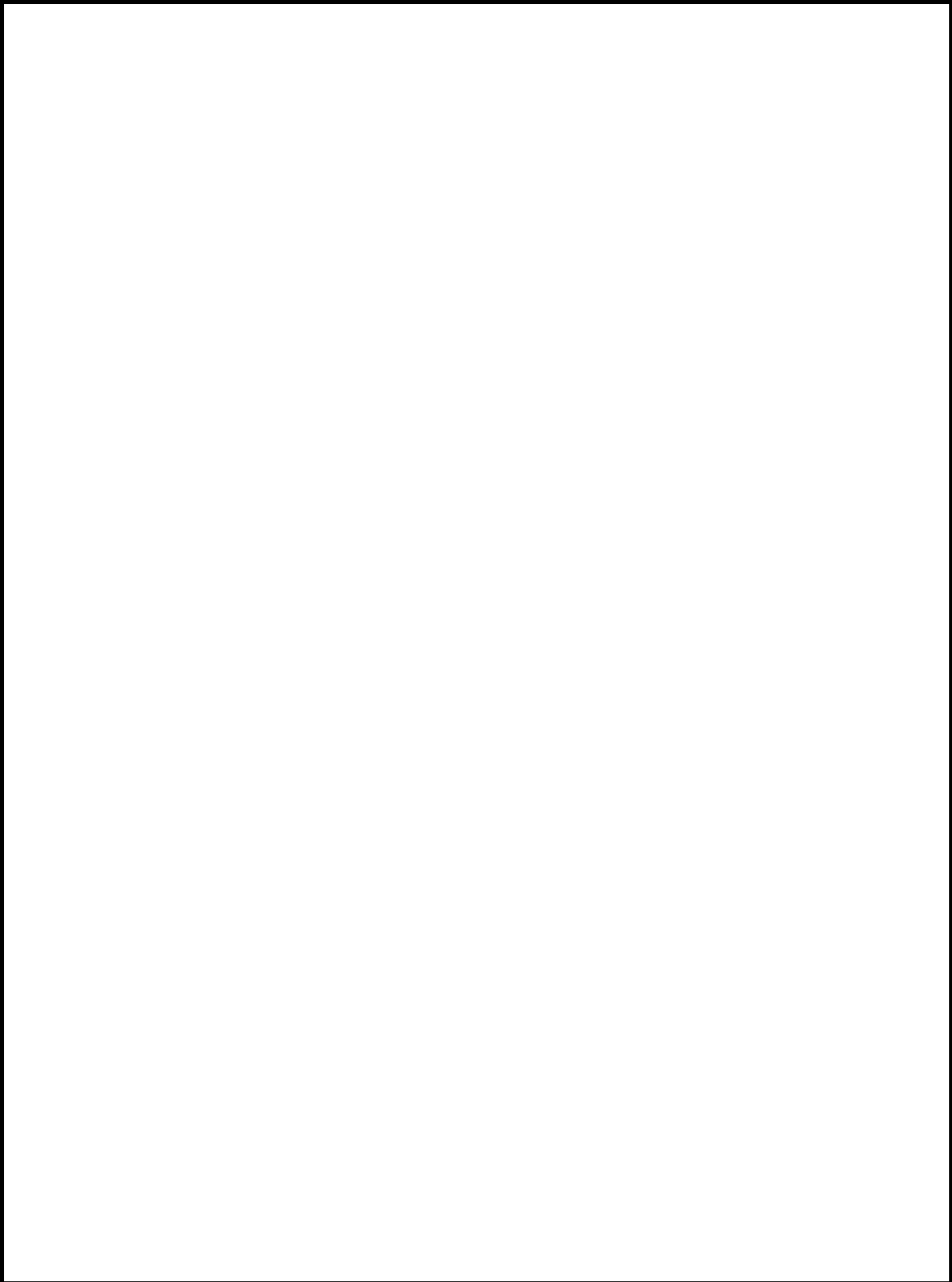

7 SCHEMATICS

3632T / HTT 13 ELECTRICAL WIRE HARNESS - ELECTRICAL	124
3632T / HTT 13 ELECTRICAL WIRE HARNESS - P1 STANDARD	125
3632T / HTT 13 ELECTRICAL WIRE HARNESS - P1 DRIVE & SET OPTION.....	126
3632T / HTT 13 ELECTRICAL WIRE HARNESS - P2.....	127
3632T / HTT 13 ELECTRICAL WIRE HARNESS - P3	128
3632T / HTT 13 ELECTRICAL WIRE HARNESS - P4	129
A-00153 MARKER AND TAIL LIGHT CONTINUOUS ROTATION WIRE HARNESS	130
A-00198 MARKER AND TAIL LIGHT 700° ROTATION WIRE HARNESS	130
A-00782 ELECTRIC BRAKE TAIL LIGHT CONTINUOUS ROTATION WIRE HARNESS	130
A-00193 ELECTRIC BRAKE TAIL LIGHT 700° ROTATION WIRE HARNESS	131
A-00210 TAIL LIGHT REAR WIRE HARNESS	131
A-00714 PLATFORM WIRE HARNESS	131
A-00716 PUMP AND CYLINDER WIRE HARNESS.....	132
A-00718 POWER WIRE HARNESS	133
A-00719 OUTRIGGER SWITCH CONTINUOUS ROTATION WIRE HARNESS	133
A-00720 OUTRIGGER COIL CONTINUOUS ROTATION WIRE HARNESS	134
A-00746 OUTRIGGER COIL AND SWITCH 700° ROTATION WIRE HARNESS	135
A-00715 ANALOG WIRE HARNESS – PRIOR TO 2008.....	136
A-00721 ANALOG WIRE HARNESS – EFFECTIVE 2008	136
A-00948 ANALOG – WIRE HARNESS FOR DRIVE & SET OPTION	137
A-00726 110 VOLTS AC TRAILER TO TOWER WIRE HARNESS.....	137
A-00722 110 VOLTS AC TOWER TO PLATFORM WIRE HARNESS	138
B01-01-0194 GFI BOX TO TRAILER WIRE HARNESS	138
B01-01-0195 GFI BOX TO PLATFORM WIRE HARNESS.....	138
A-00272 BATTERY LAYOUT	139
A-00943 BATTERY LAYOUT FOR DRIVE & SET OPTION	140
A-00700 AIR LINE TO PLATFORM	141
A-00701 WATER LINE TO PLATFORM	141
HYDRAULIC SCHEMATIC.....	142
HYDRAULIC SCHEMATIC FOR DRIVE & SET OPTION.....	144
A-00182 HYDRAULIC HOSE LAYOUT – TRAILER 360° CONTINUOUS ROTATION	146
A-03182 HYDRAULIC HOSE LAYOUT - TRAILER 700° ROTATION	147
A-00269 HYDRAULIC HOSE LAYOUT – BOOM	148
A-00928 MANIFOLD FOR DRIVE & SET OPTION	150
A-00938 HYDRAULIC HOSE LAYOUT FOR DRIVE & SET OPTION.....	152
A-00939 OUTRIGGER COIL TO SWITCHES FOR DRIVE & SET OPTION	154
A-00947 MANIFOLD HARNESS FOR DRIVE & SET OPTION	155
A-00946 BRAKE SWITCH HARNESS FOR DRIVE & SET OPTION	155

3632T / HTT 13 ELECTRICAL WIRE HARNESS - ELECTRICAL

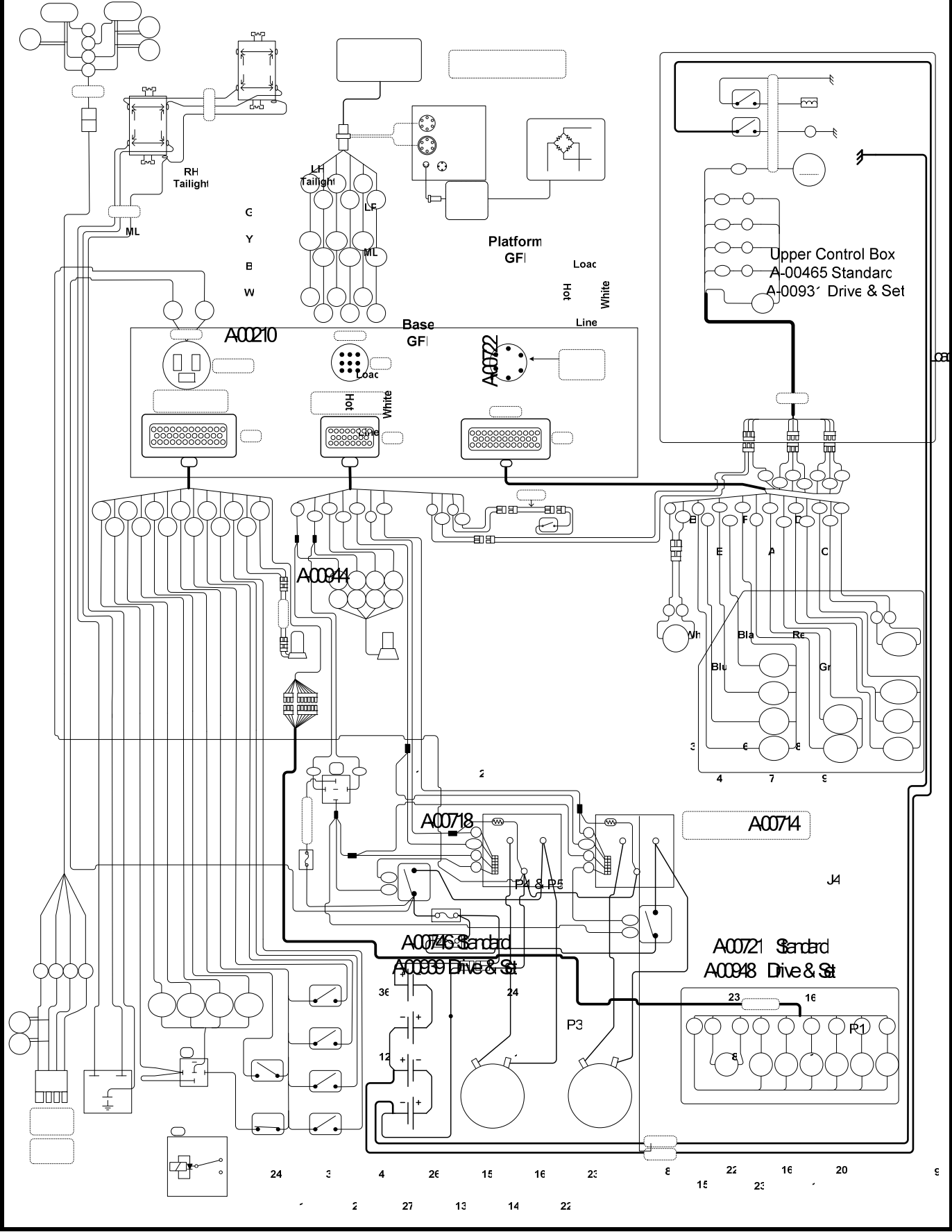

C-26 Rest
Hyd

A0092
Cat Gil Mdlle

- 1- Red
- 2- White
- 3- Green
- 4- Black

35

12

4
15

3632T / HTT 13 ELECTRICAL WIRE HARNESS - P1 DRIVE & SET OPTION

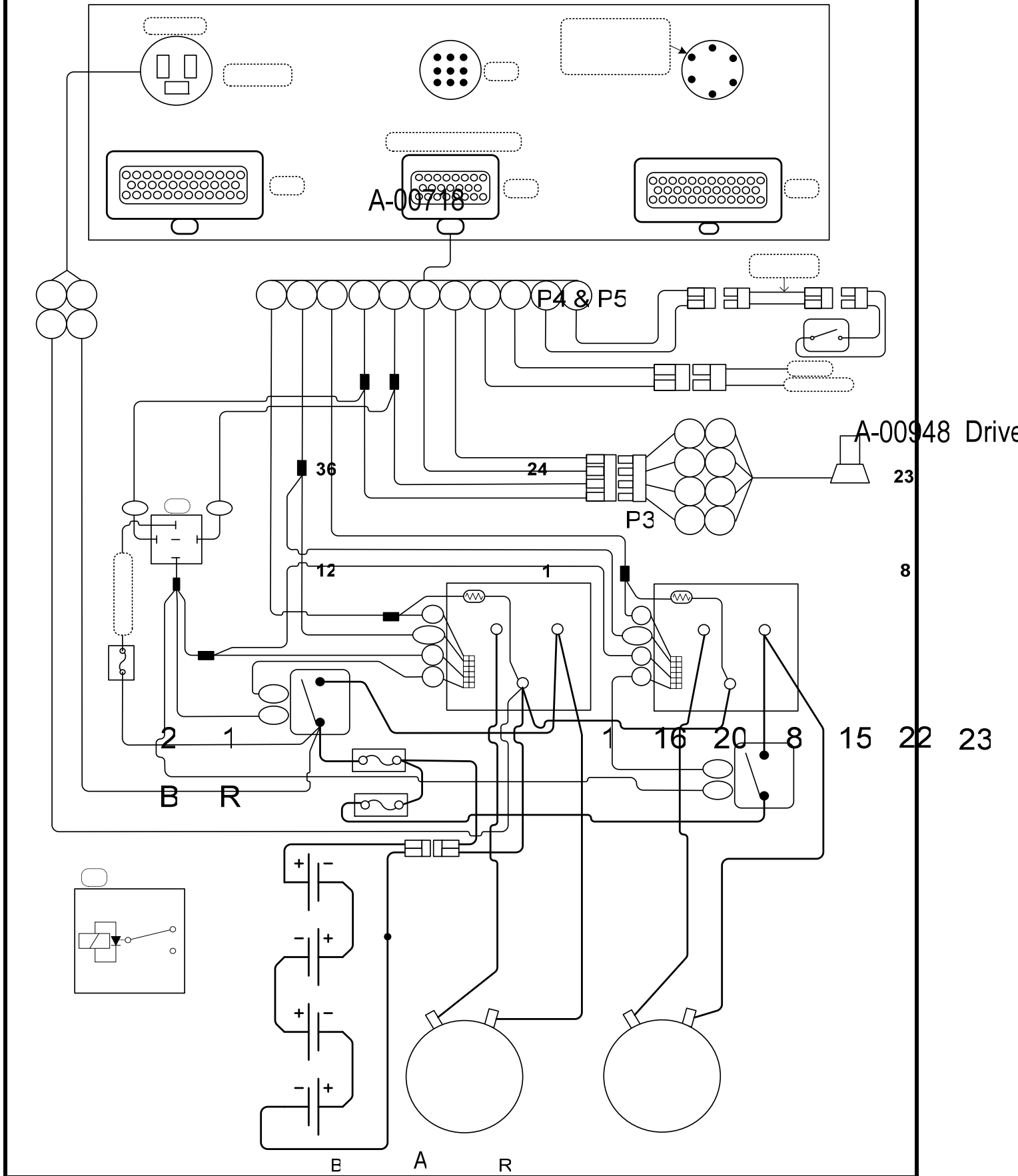

3632T / HTT 13 ELECTRICAL WIRE HARNESS - P2

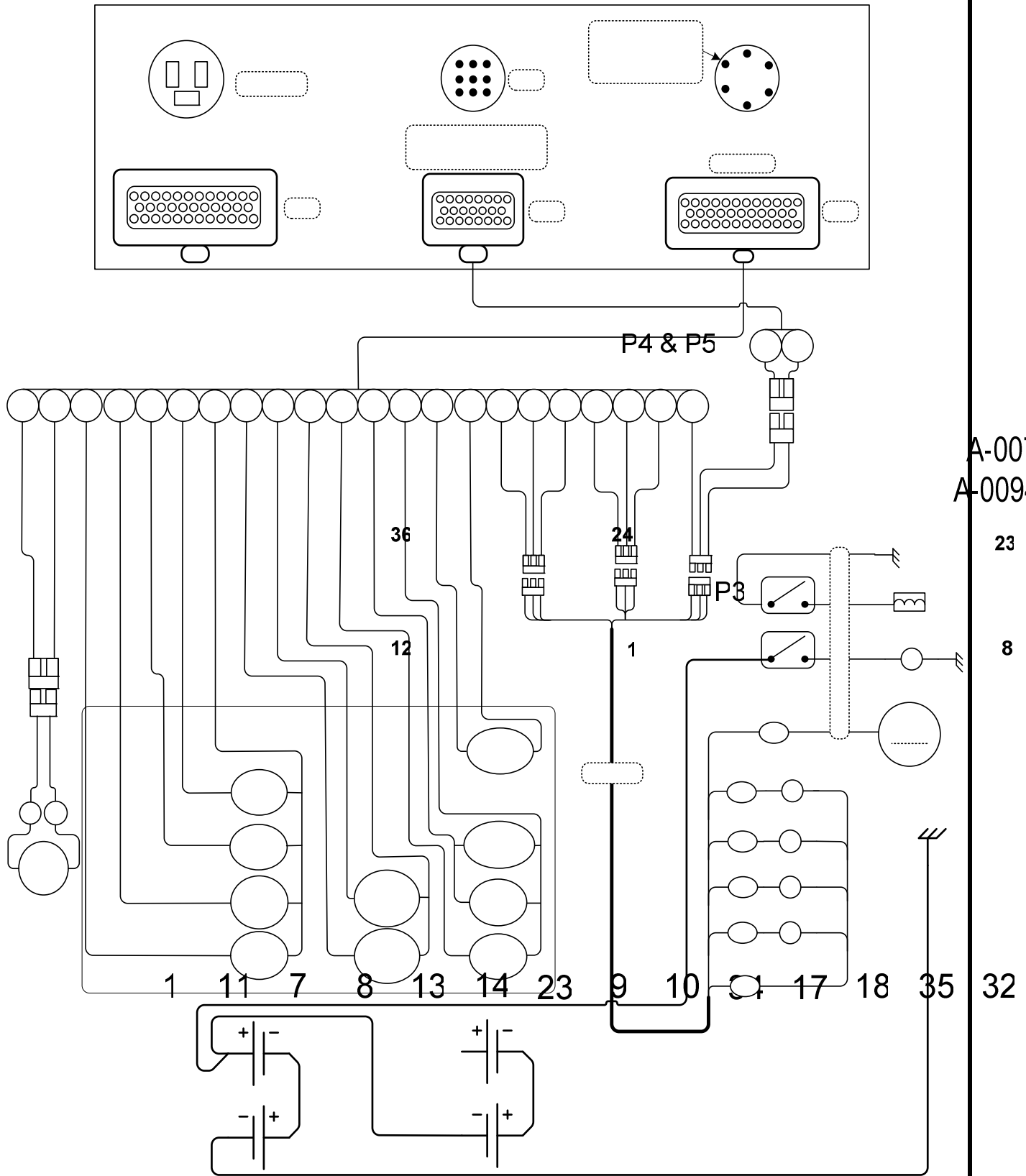

A-0072
A-00948

23
8

3632T / HTT 13 ELECTRICAL WIRE HARNESS - P3

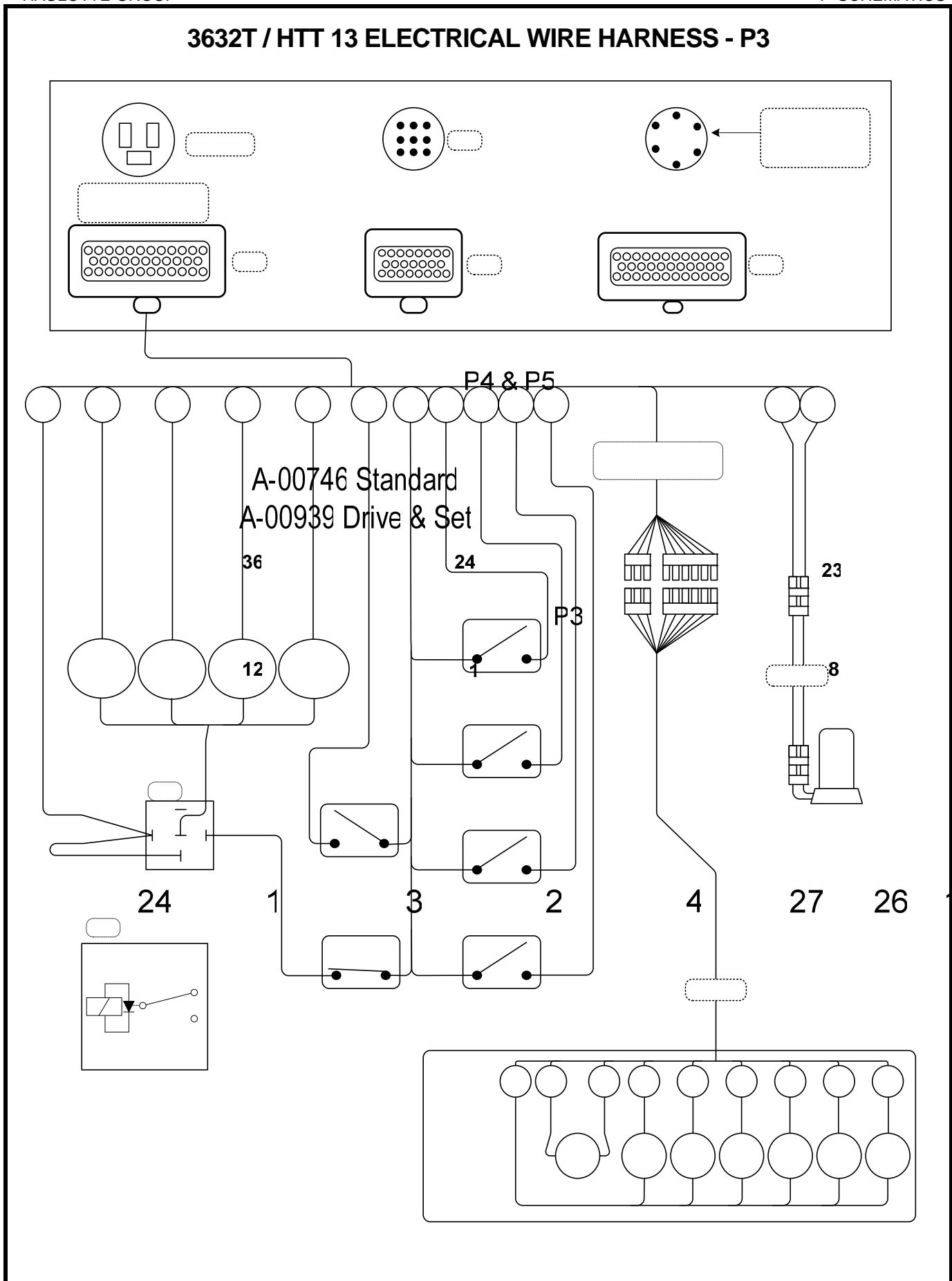

3632T / HTT 13 ELECTRICAL WIRE HARNESS - P4

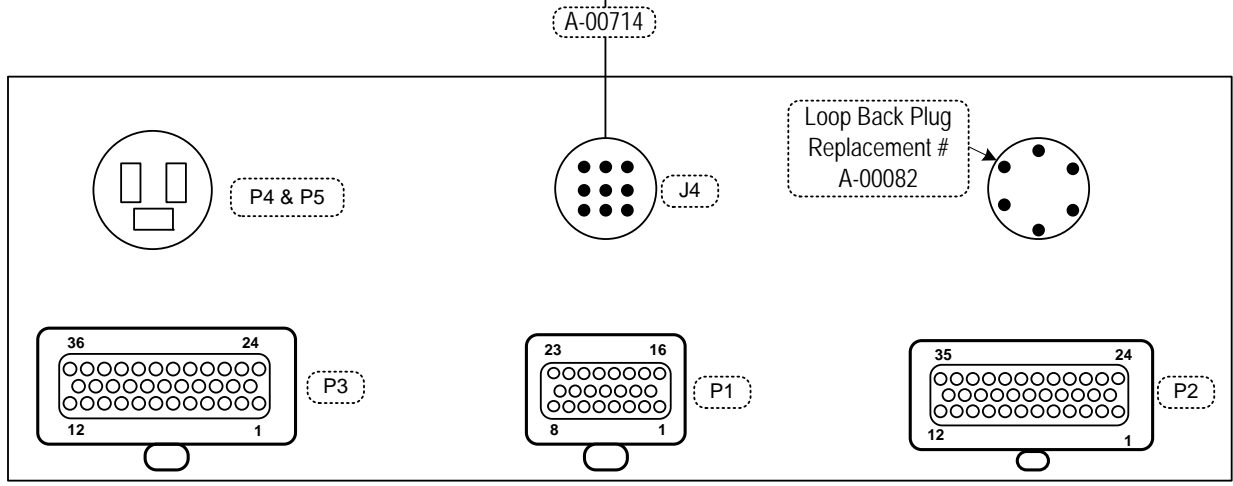
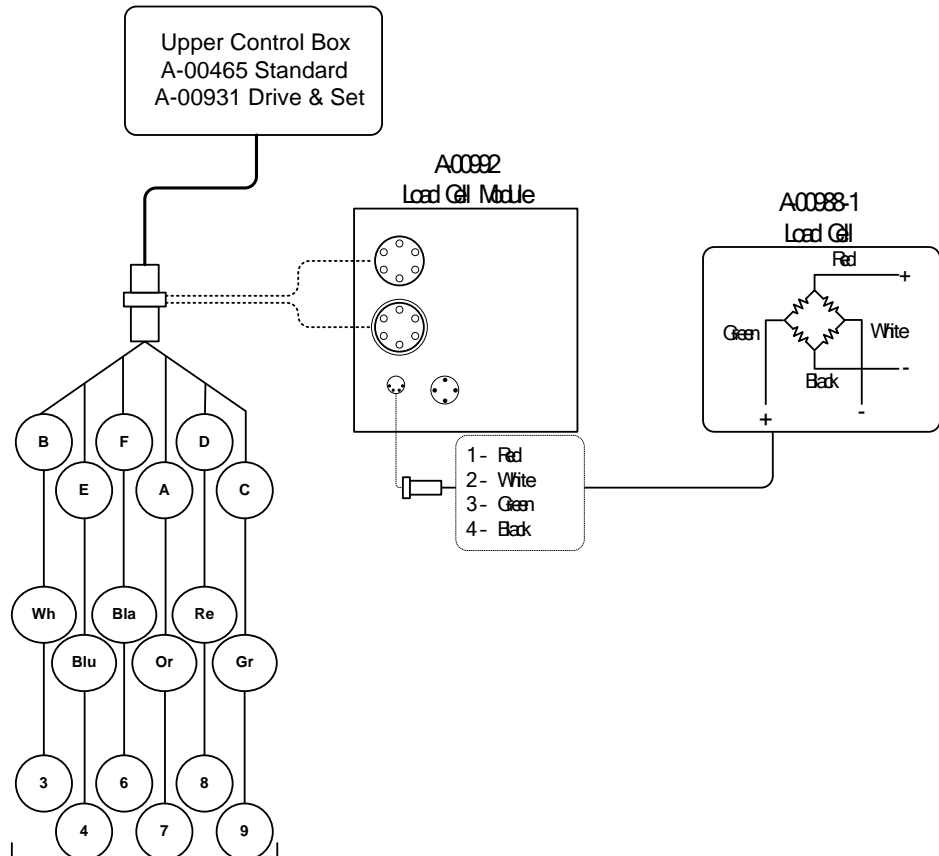

A-00153 MARKER AND TAIL LIGHT CONTINUOUS ROTATION WIRE HARNESS

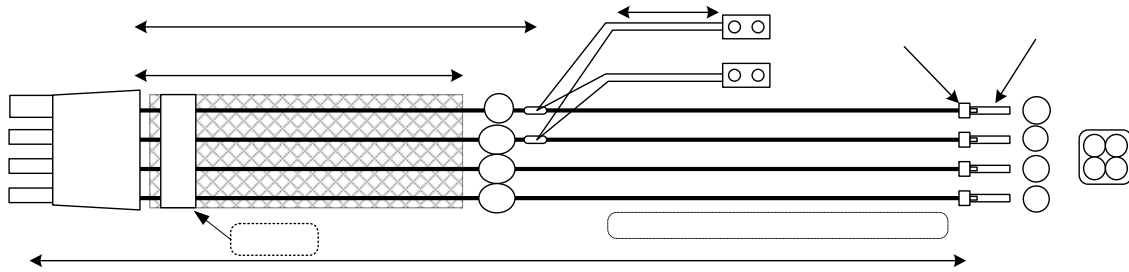

54" Splices

A-00198 MARKER AND TAIL LIGHT 700° ROTATION WIRE HARNESS

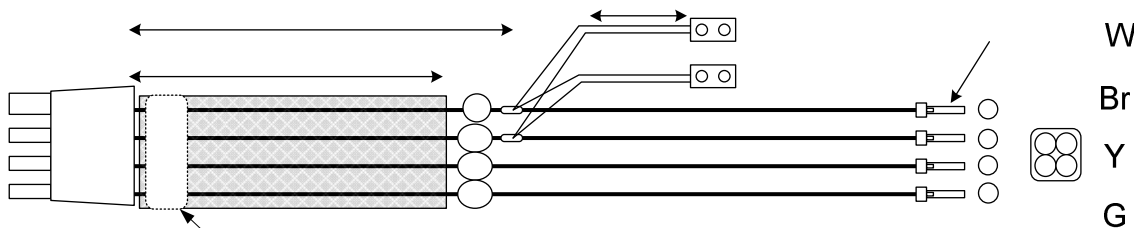

4Pin Flat Plug

Part Number
Rev- Label

W
Br
Y
G

A-00782 ELECTRIC BRAKE TAIL LIGHT CONTINUOUS ROTATION WIRE HARNESS

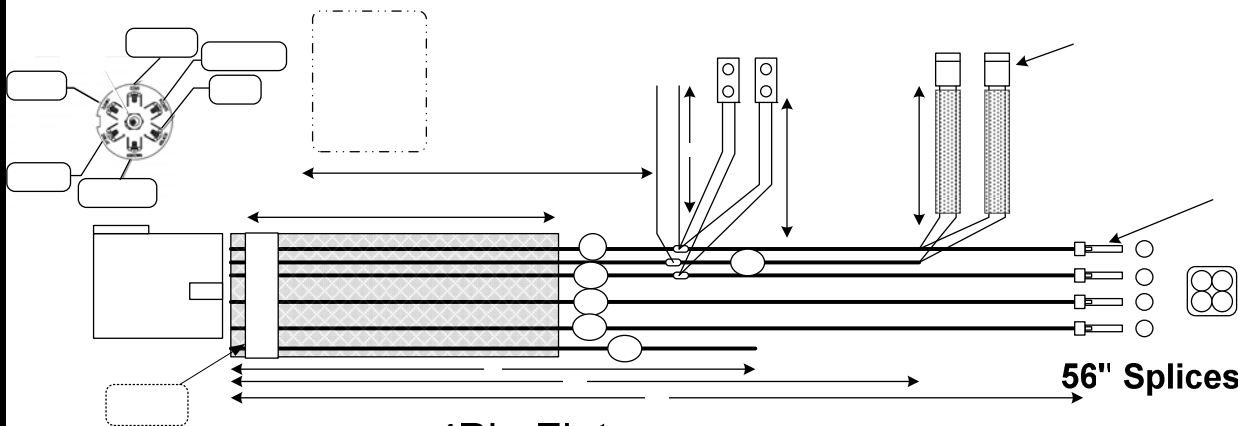

4Pin Flat Plug

50" Braided Loom & Heat Seal

56" Splices

Ground(-)

Marker Lights

Driver Side Signal

Part Number
Rev-

W
Br
Y

A-00193 ELECTRIC BRAKE TAIL LIGHT 700° ROTATION WIRE HARNESS

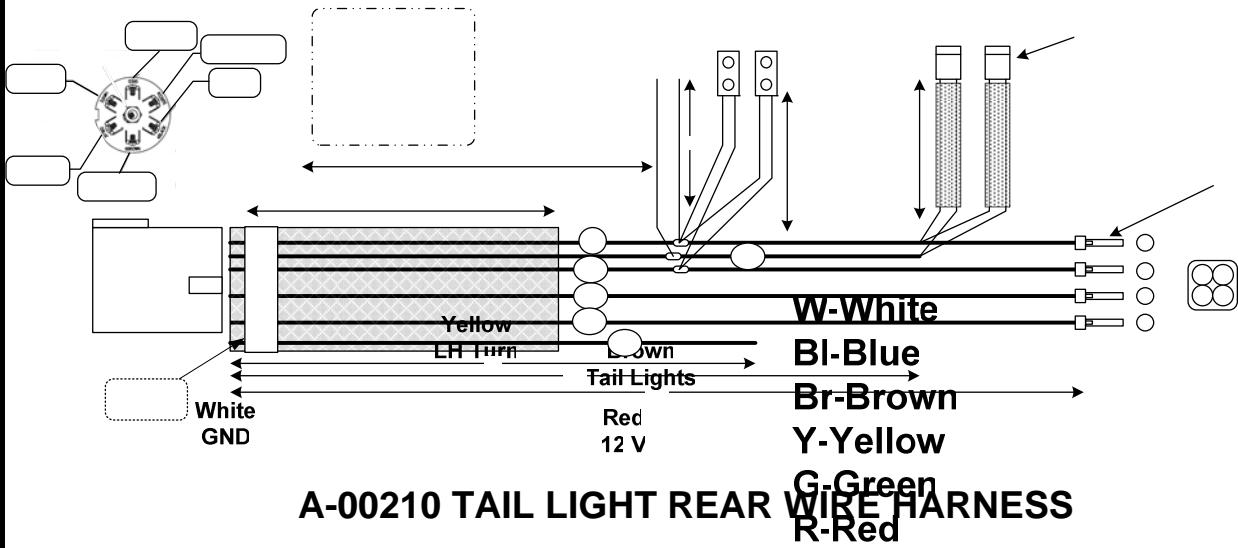

A-00210 TAIL LIGHT REAR WIRE HARNESS

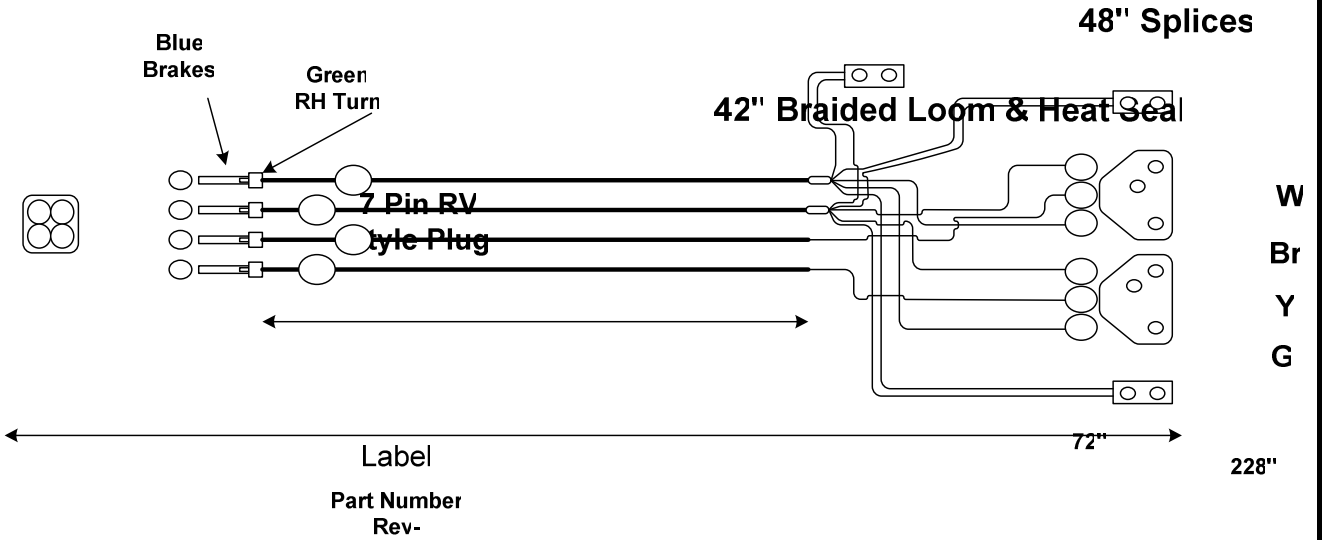

A-00714 PLATFORM WIRE HARNESS

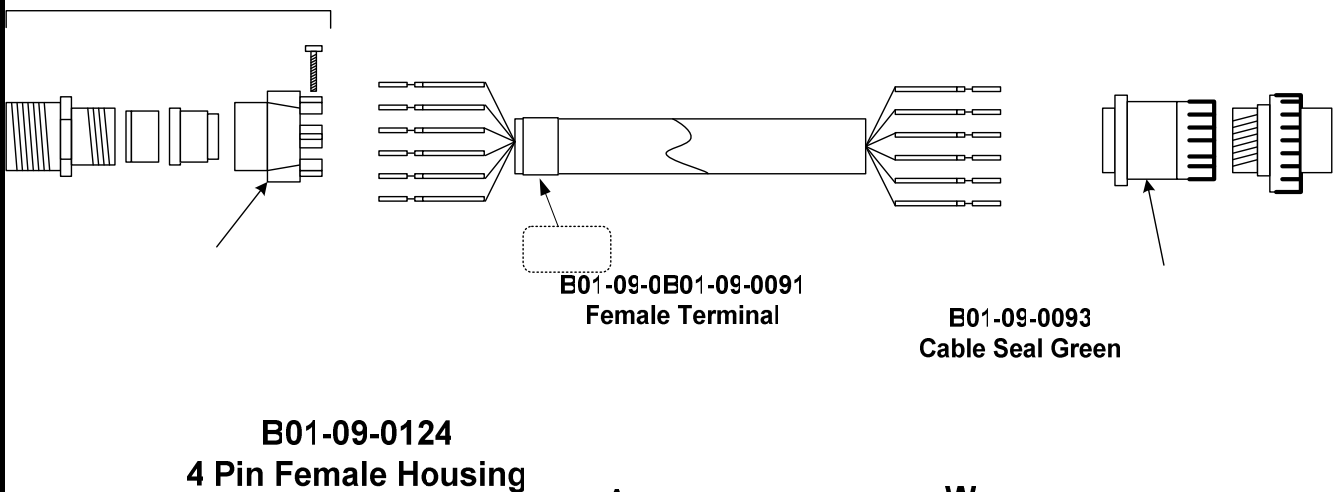

A W

B Br

C Y

A-00716 PUMP AND CYLINDER WIRE HARNESS

24

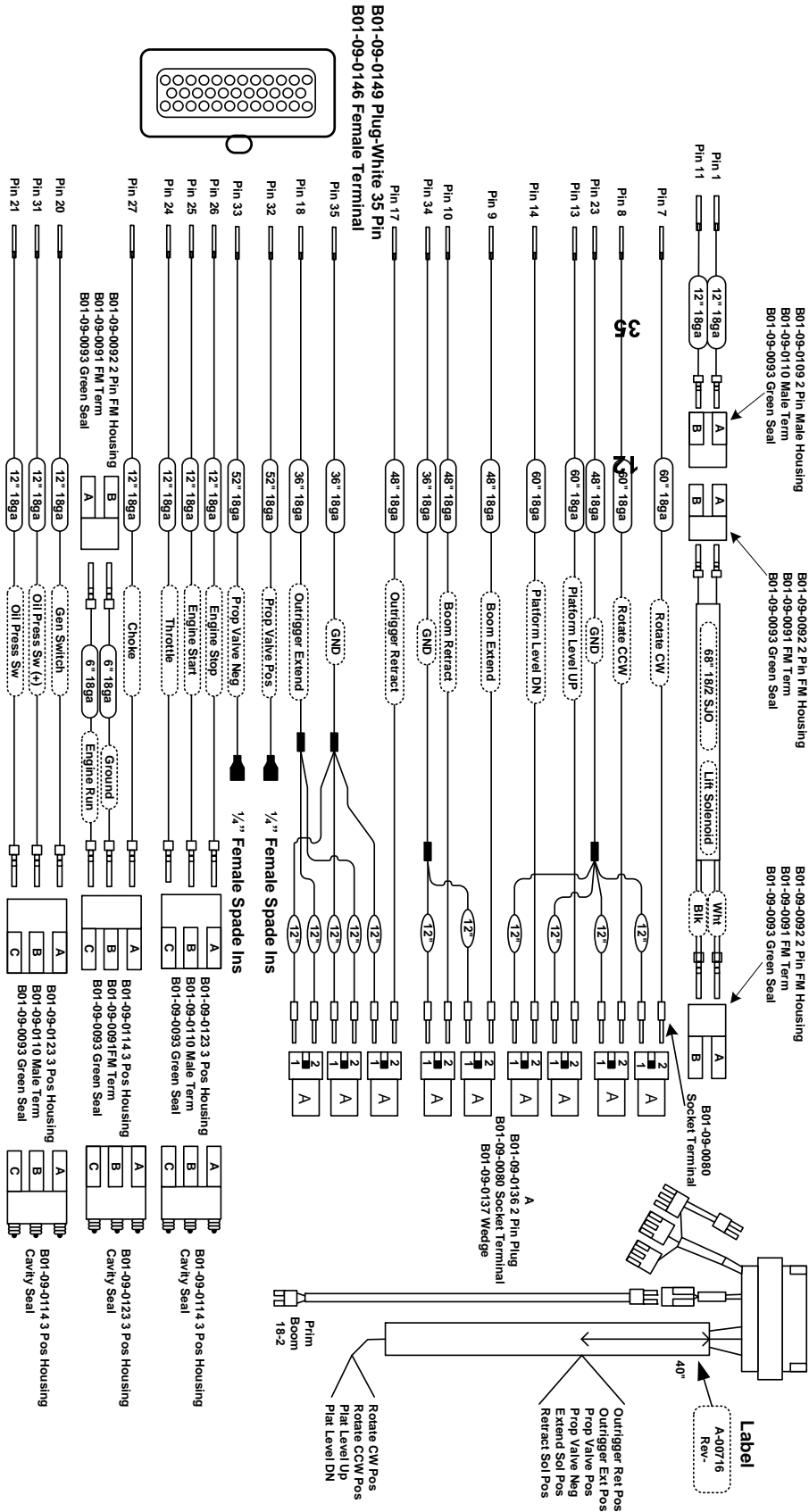

A-00718 POWER WIRE HARNESS

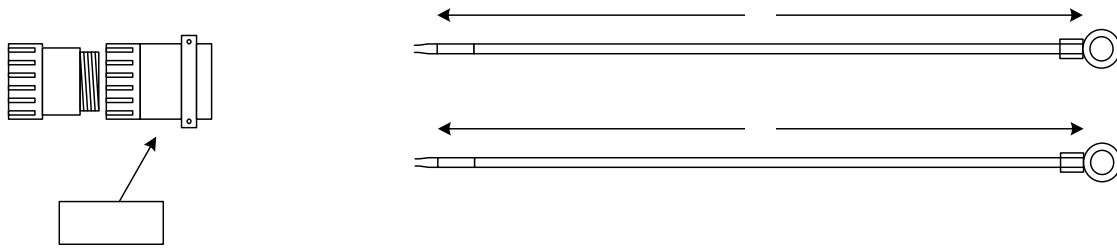

Pin 1

Pin 2

A-00719 OUTRIGGER SWITCH CONTINUOUS ROTATION WIRE HARNESS

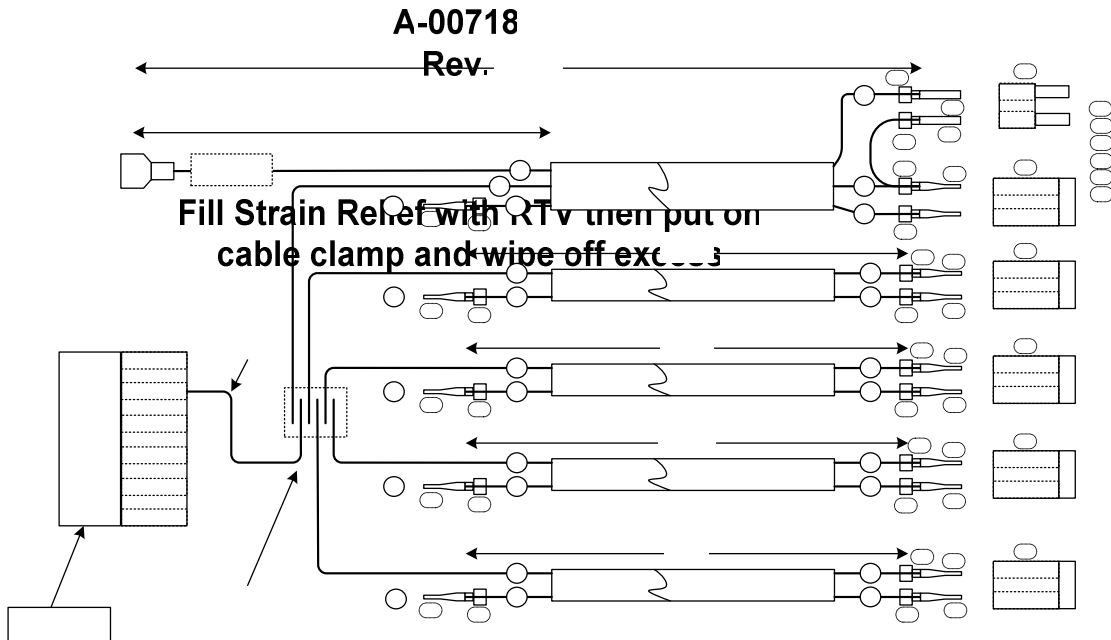

A-00720 OUTRIGGER COIL CONTINUOUS ROTATION WIRE HARNESS

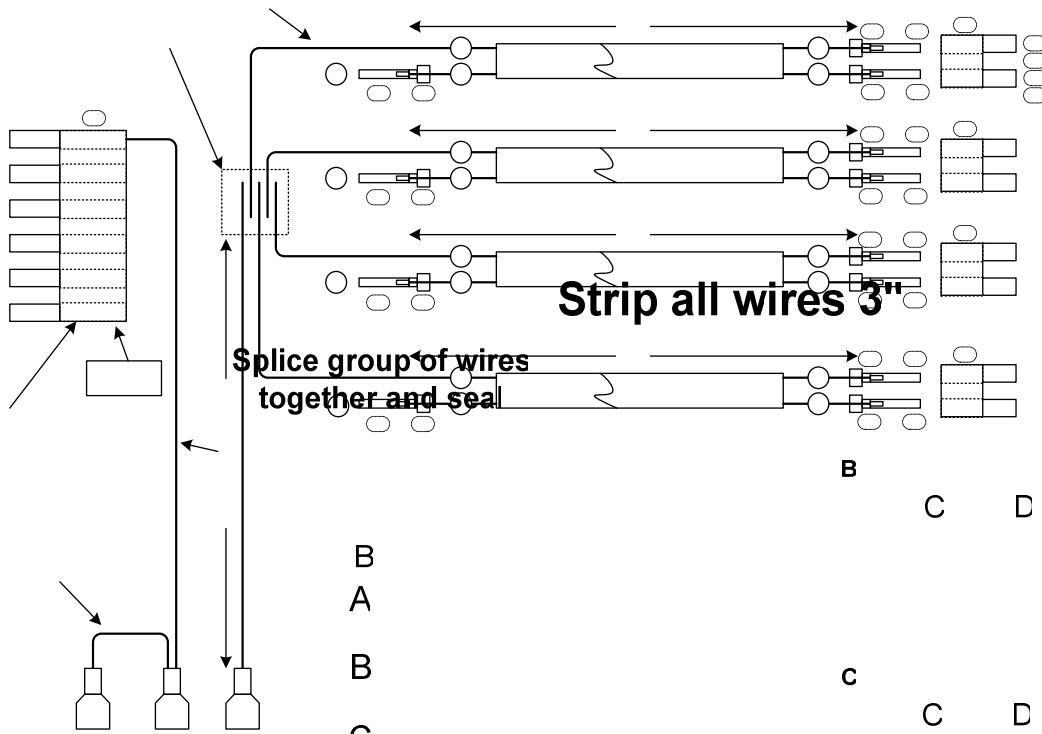

Cables-SJO
Or Equivalent
Oil Resistant

Splice group of wires
together and seal

Strip all wires 3"

Plug F with
12010300 Cavity Plug

A-00720
Rev

8" 18 ga Black wire

3" 18ga Black
Oil Resistant

B			B	18-2	(86"
W					
	C	D			
B			B	18-2	(56"
W					
	C	D			
B			B	18-2	(86"
W					
	D	D			
B			B	18-2	(56"
W					
	E	D			
	C	D			

A-00746 OUTRIGGER COIL AND SWITCH 700° ROTATION WIRE HARNESS

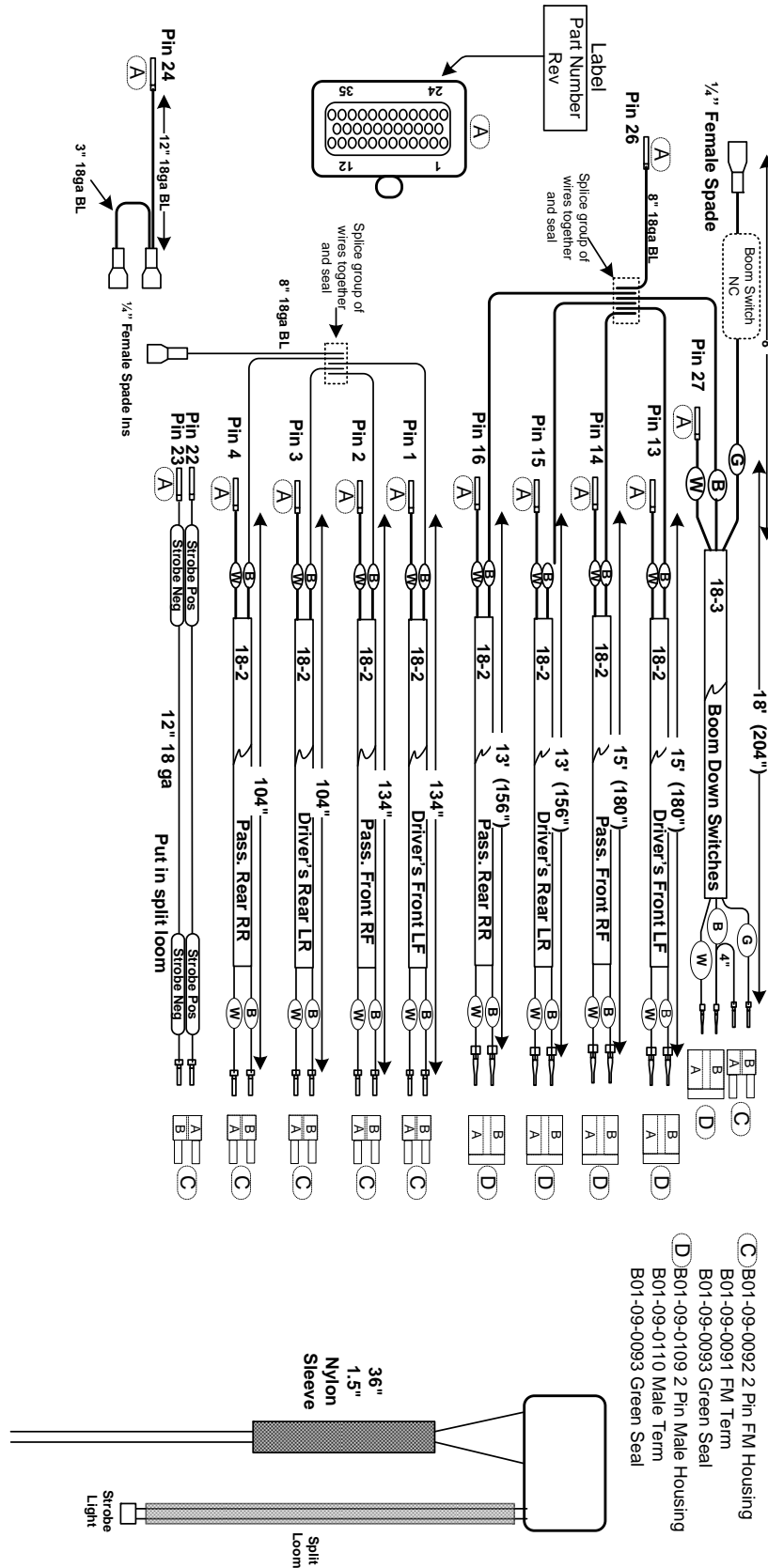

A-00715 ANALOG WIRE HARNESS – PRIOR TO 2008

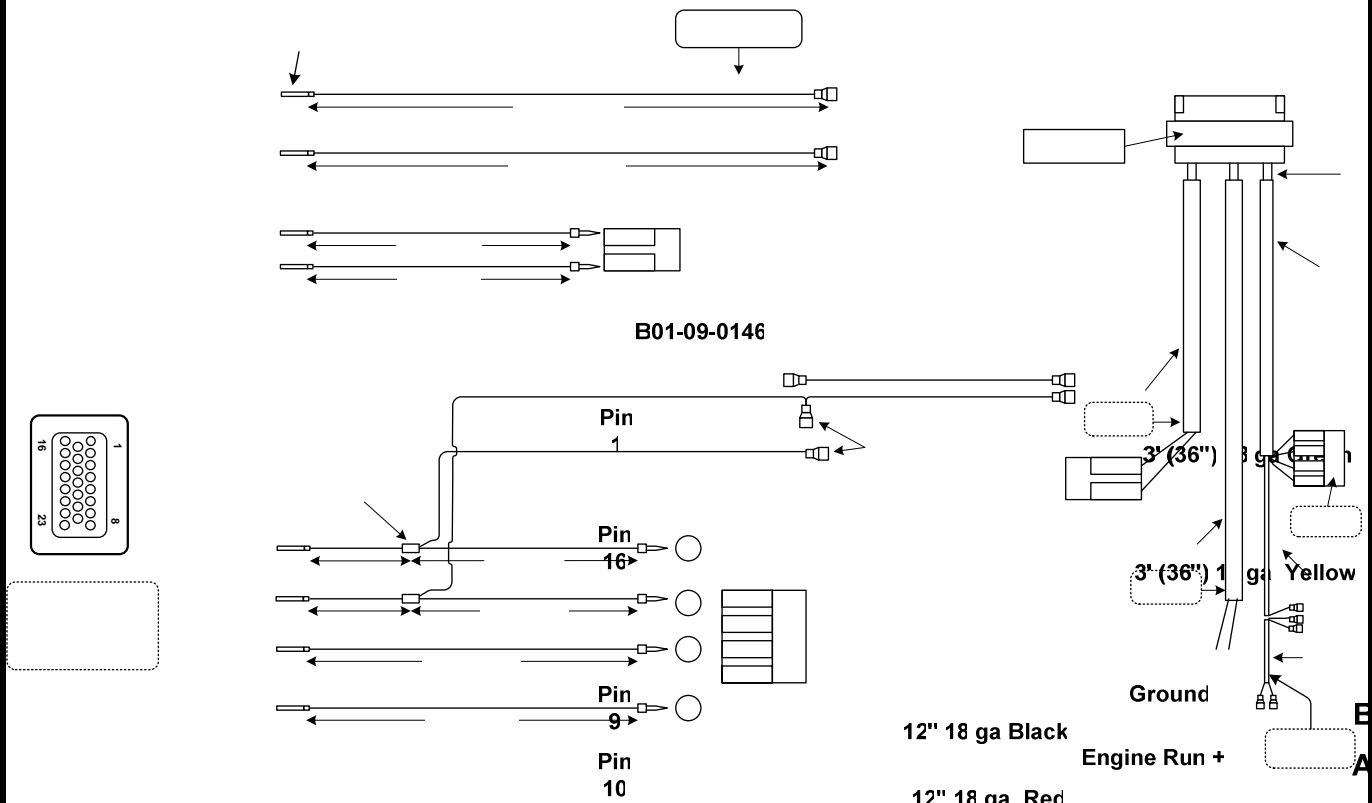

A-00721 ANALOG WIRE HARNESS – EFFECTIVE 2008

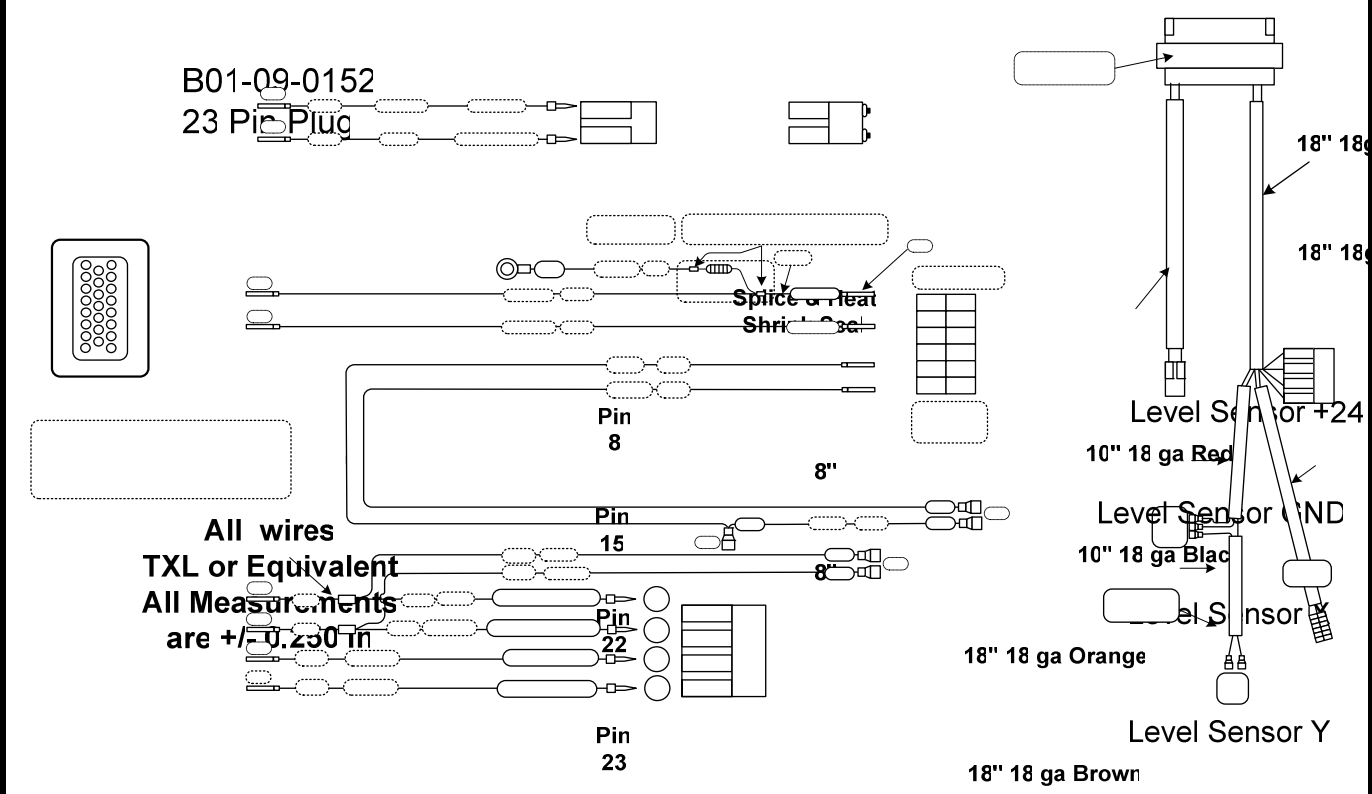

A-00948 ANALOG – WIRE HARNESS FOR DRIVE & SET OPTION

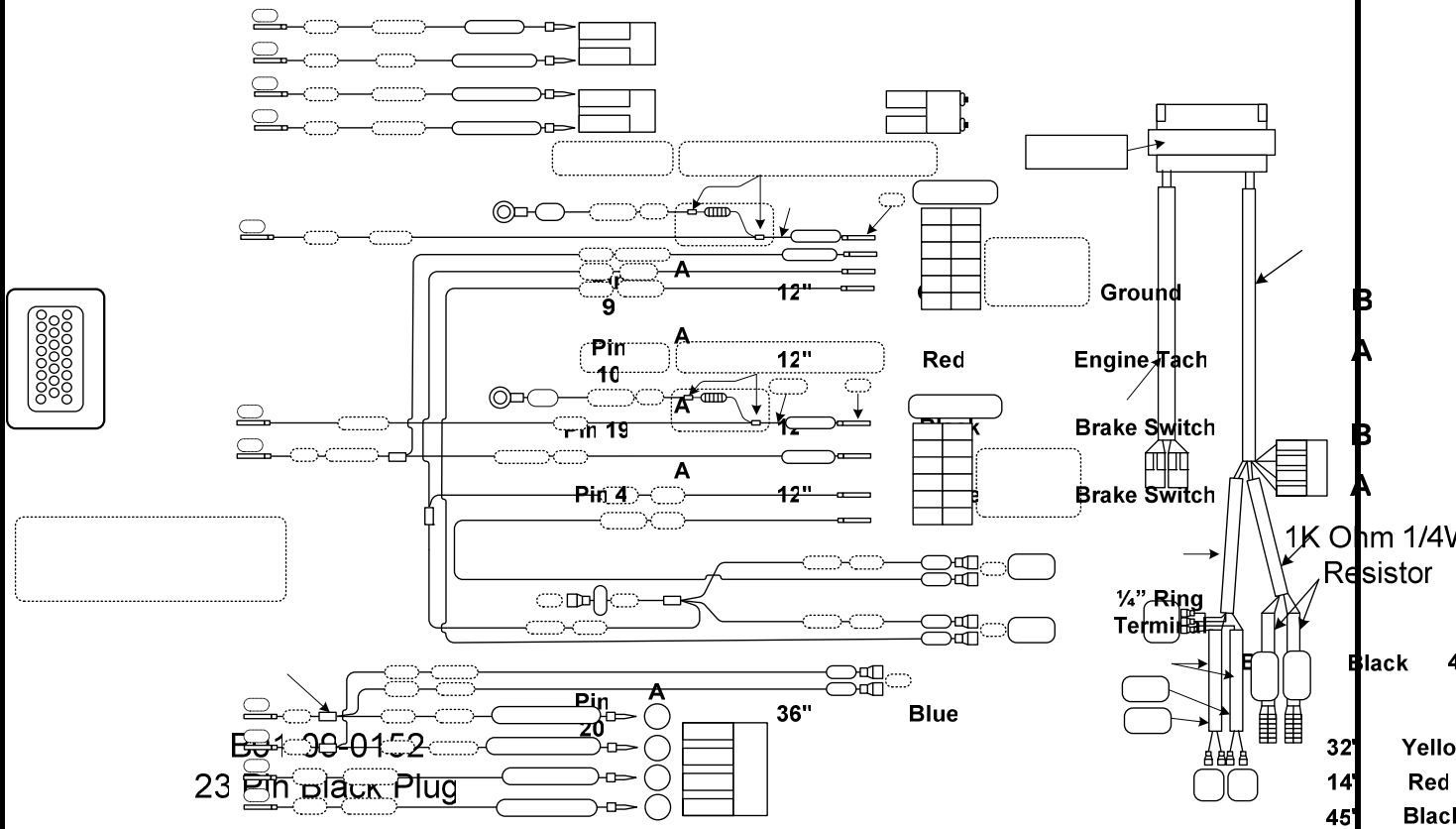

A-00726 110 VOLTS AC TRAILER TO TOWER WIRE HARNESS

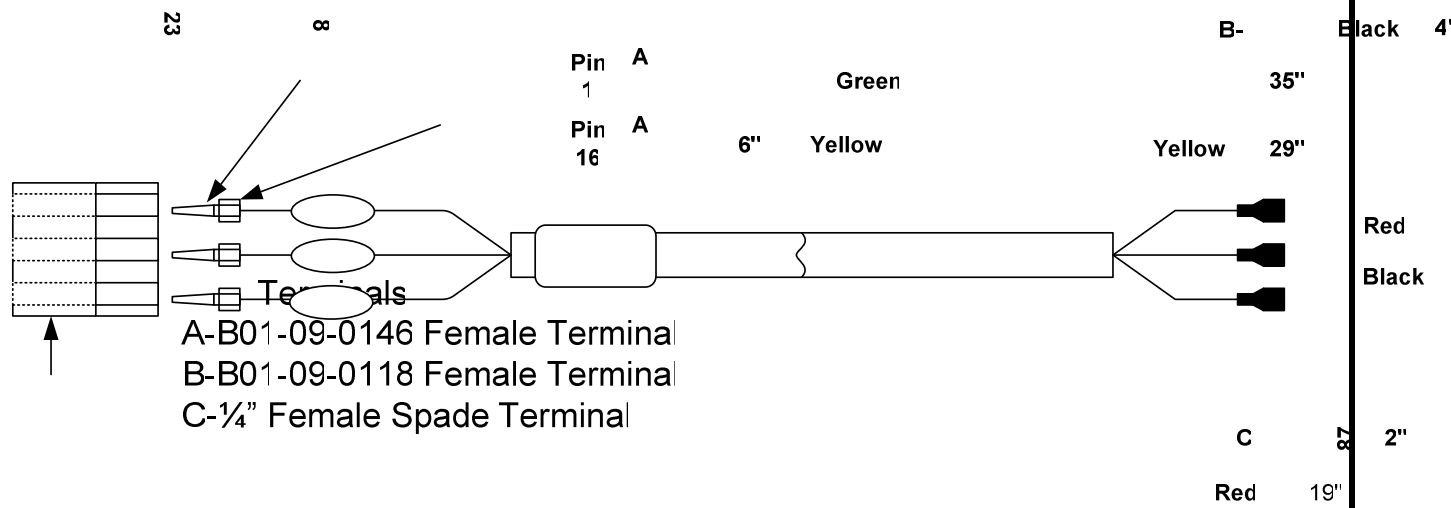

- A-B01-09-0146 Female Terminal
- B-B01-09-0118 Female Terminal
- C-1/4" Female Spade Terminal

Pin	Color	Length	Terminal	Notes
Pin 1	Green	35"	Black 4"	
Pin 16	Yellow	29"	Yellow	
Pin 8	Red	10"	Red	Level Sensor +24
Pin 15	Black	10"	Black	Level Sensor GND
Pin 22	Orange	18"	Black	Level Sensor X
Pin	Brown	18"	Black	Level Sensor Y

A-00722 110 VOLTS AC TOWER TO PLATFORM WIRE HARNESS

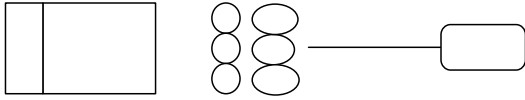

B01-09-0123 3 Pin Male Housing

B01-09-0120 Male Terminal

B01-01-0195 4 Pin GFI Box

B01-01-0195 4 Pin GFI Box TO TRAILER WIRE HARNESS

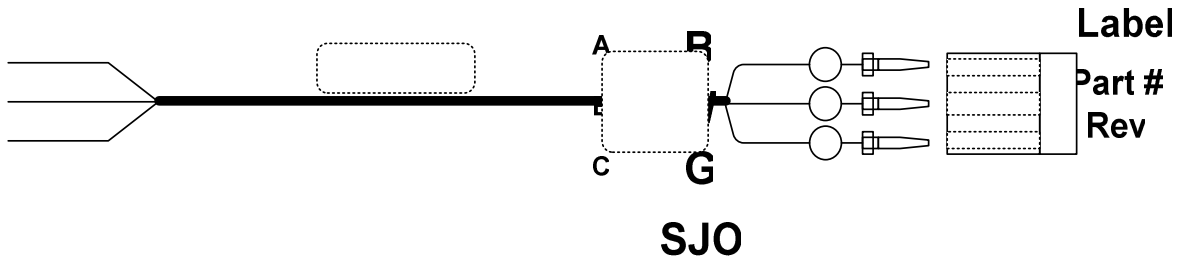

SJO

B01-01-0195 GFI BOX TO PLATFORM WIRE HARNESS



**18" 14-3 SJO
Or Equivilant**

**Label
Part #
Rev-
Trailer
10VAC**

A-00272 BATTERY LAYOUT

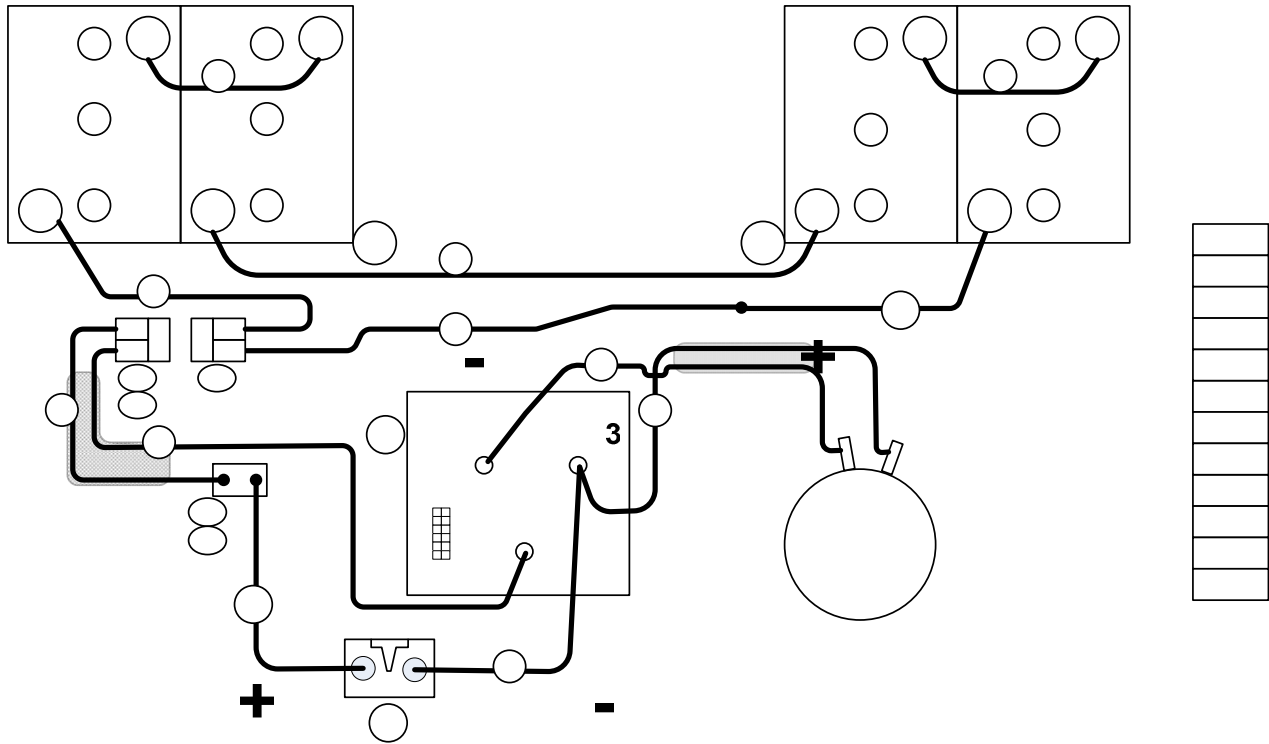

Item No.	Gauge	Length	Color	End	End	Qty.
1	2 gauge	30"	Red	5/16 Ring	SBC Lug	1
2	2 gauge	45"	Black	5/16 Ring	5/16 Ring	1
3	2 gauge	8"	Black	5/16 Ring	5/16 Ring	2
4	2 gauge	22"	Black	5/16 Ring	SBC Lug	1
5	2 gauge	18"	16 Red	Motor	SBC Lug	1
6	2 gauge	17"	Black	Controller	SBC Lug	1
7	2 gauge	22"	Red	5/16 Ring	5/16 Ring	1
8	2 gauge	48"	Red	5/16 Ring	5/16 Ring	1
9	2 gauge	45"	Black	5/16 Ring	5/16 Ring	1
10	2 gauge	19"	Black	5/16 Ring	5/16 Ring	1
11	2 gauge	13"	Red	5/16 Ring	5/16 Ring	1

ITEM NO.	PART NUMBER	DESCRIPTION	QTY.
12	B01-10-0330	Fuse, 200 Amp	1
13	B01-10-0331	Fuse Holder, 200 Amp	1
14	B01-06-0058	Contactora, 24 Volt DC	1
15	A-00297	Motor Controller	1
16	B01-09-0131	SBC Plug Connector	1
17	B01-09-0132	A-Frame Handle	1

A-00943 BATTERY LAYOUT FOR DRIVE & SET OPTION

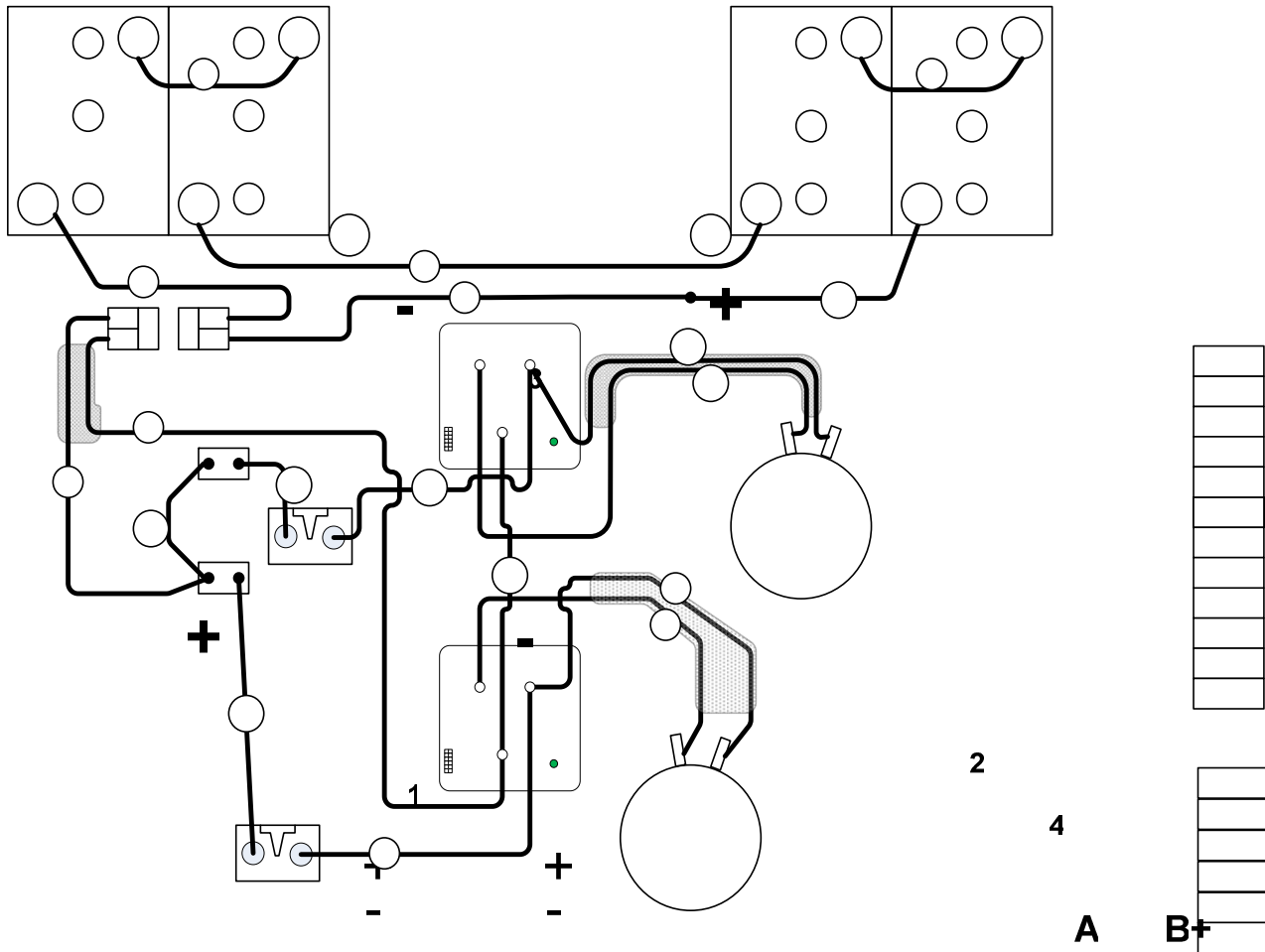

Motor

A-00943 BATTERY LAYOUT - DRIVE & SET OPTION

FOR ITEMS 1-11 SEE A-00272 BATTERY LAYOUT PAGE

Item No.	Gauge	Length	Color	End	End	Qty.
D1	2 gauge	6"	Red	5/16 Lug	5/16 Lug	1
D2	2 gauge	30"	Red	5/16 Lug	5/16 Lug	1
D3	2 gauge	20"	Black	5/16 Lug	5/16 Lug	1
D4	2 gauge	40"	Red	5/16 Lug	5/16 Lug	1
D5	2 gauge	40"	Black	5/16 Lug	5/16 Lug	1
D6	2 gauge	20"	Red	5/16 Lug	5/16 Lug	1
Contactor 24VDC 100AMP B01-06-0058						
PART NUMBER	DESCRIPTION					QTY.
B01-10-0330	Fuse, 200 Amp					2
B01-10-0331	Fuse Holder, 200 Amp					2
B01-06-0058	Contactor, 24 Volt DC					2
A-00297	Motor Controller					2
B01-09-0131	SBC Plug Connector					1
B01-09-0132	A-Frame Handle					1

Motor Controller

A2E7
M

HYDRAULIC SCHEMATIC

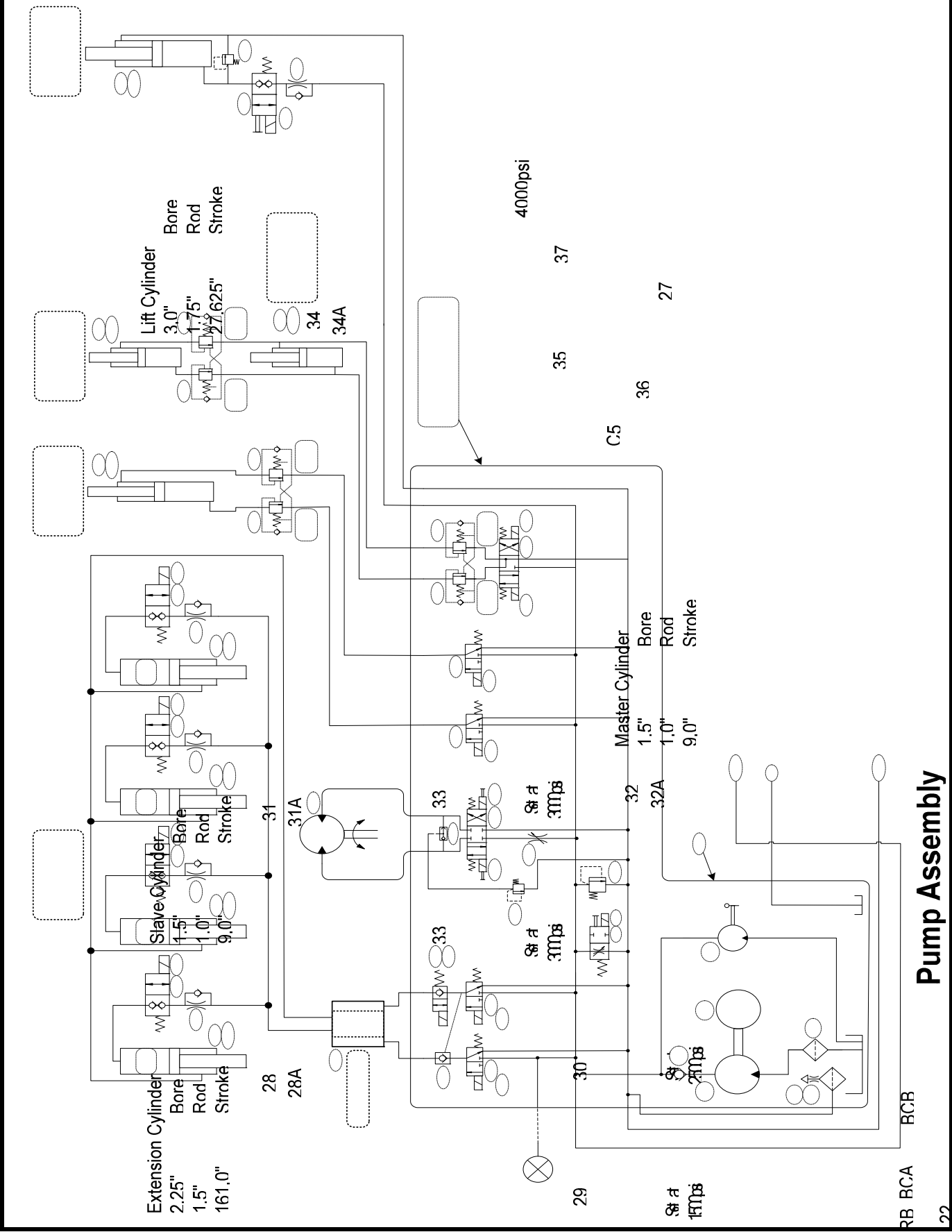

**Pump Assembly
A-00254HS**

PRB BCA RCB

22

HYDRAULIC SCHEMATIC

ITEM NO.	PART NUMBER	DESCRIPTION
1	B02-15-0470	Pump - Gear 2.0cc / Rev
2	B02-15-0471	Motor, 24 Volt DC 3KW 3300 rpm
3	B02-15-0472	Pump, Hand .5cc / Pump
4	B02-14-0091	Valve, Check
5	B02-15-0480	Strainer, Suction
6	B02-15-0501	Filter & Housing
7	B02-00-0070	Filter, Replacement
8	B02-14-0094L	Valve, Prop
9	B02-14-0095	Coil, Prop
10	B02-14-0111	Valve, Relief - Set at 3000 psi
11	B02-14-0109	Valve, Outtrigger - Pump
12	B02-14-0113	Coil 20 Volt DC
13	B02-14-0089	Valve, Check - Outtrigger - Pump
14	B02-14-0112	Coil 20 Volt DC
15	B02-14-0110	Valve, Check - PO
16	B02-14-0099	Valve, Cart - Rotate
17	B02-14-0097	Valve, Relief 800 psi - Rotate
18	B02-14-0114	Valve, Flow Control
19	B02-14-0098	Valve, Shuttle
20	B02-14-0108	Valve, Cart - Extend Cylinder
21	B02-14-0101	Valve, Cart - Basket Level
22	B02-14-0100	Valve, Counter Balance
23	B02-15-0513	Reservoir, 4.3 Gallon Capacity Useable
24	A-00138	Cylinder, Outtrigger
24A	B02-13-0129	Seal Kit, For A-00138
25	B02-04-0118	Valve, Double Check
26	B01-08-0022	Coil, 20 Volt DC
27	B02-14-0087	Orifice disc, .037
28	A-00550	Cylinder, Extension
28A	B02-13-0132	Seal Kit, A-00550
29	B02-04-0106	Valve, Counter Balance - CBCA-LHN
30	B02-04-0105	Valve, Counter Balance - CABG-LGN
31	A-00553	Cylinder, Slave
31A	B02-13-0131	Seal Kit, For A-00553
32	A-00552	Cylinder, Master
32A	B02-13-0130	Seal Kit, For A-00552
33	B02-04-0095	Valve, Counter Balance - CABG-LHN
34	A-00551	Cylinder, Lift
34A	B02-13-0128	Seal Kit, For A-00551
35	B02-04-0101	Valve, Double Check
36	B01-08-0019A	Coil, 20 Volt DC
37	B02-04-0109	Relief, Thermal - Set at 4000 psi
38	B02-06-0018	Slew Drive, 80CC
39	A-00257	Hydraulic Swivel-Only on Machines with 360°Continuous Rotation

HYDRAULIC SCHEMATIC FOR DRIVE & SET OPTION

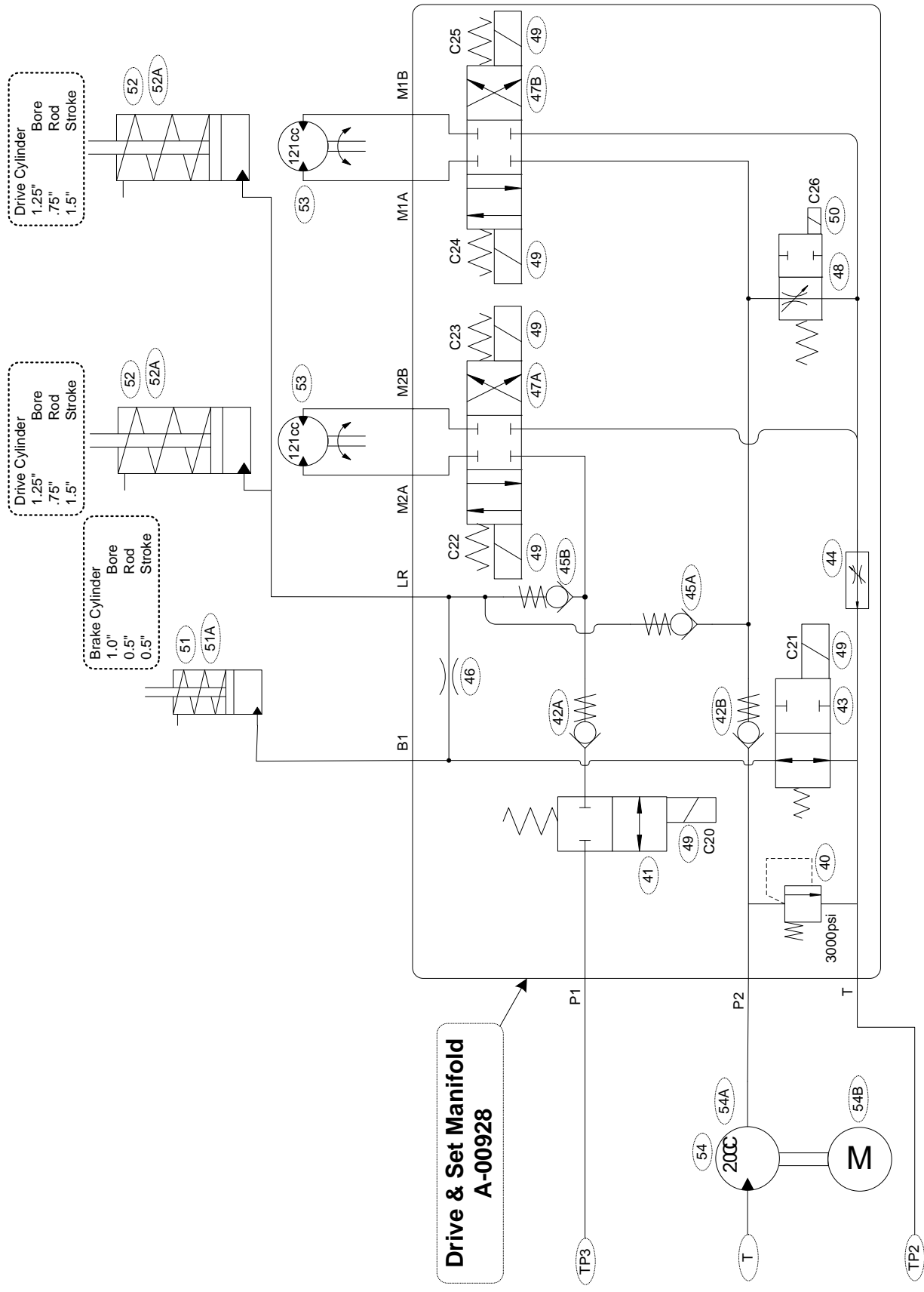

HYDRAULIC SCHEMATIC FOR DRIVE & SET OPTION

ITEM NO.	PART NUMBER	DESCRIPTION
40	B02-15-0515	Valve, Pressure Relief - 3000 PSI
41	B02-15-0516	Valve, Cart NC
42A & 42B	B02-14-0092	Valve, Check
43	B02-15-0518	Valve, Cart NO
44	B02-15-0519	Valve, Flow Control
45A & 45B	B02-15-0520	Valve, Check
46	B02-15-0521	Orifice, 1.0 mm
47A & 47B	B02-15-0522	Valve, Directional
48	B02-15-0523	Valve, Prop NO
49	B02-15-0525	Coil, 20 Volt DC Deutsch Connector
50	B02-15-0524	Coil, 20 Volt DC Deutsch Connector - Prop valve
51	A-00930	Cylinder, Brake Release
51A	B02-13-0157	Seal Kit, For A-00930
52	A-00906	Cylinder, Drive and Set
52A	B02-13-0153	Seal Kit, For A-00906
53	A-00915	Motor, Hydraulic - 121cc
54	A-00235	Auxiliary Pump
54A	B02-15-0529	Pump, Gear - 2.0cc / Rev
54B	B02-15-0528	Motor, 24 Volt DC - 3KW - 3300 rpm

A-00182 HYDRAULIC HOSE LAYOUT – TRAILER 360° CONTINUOUS ROTATION

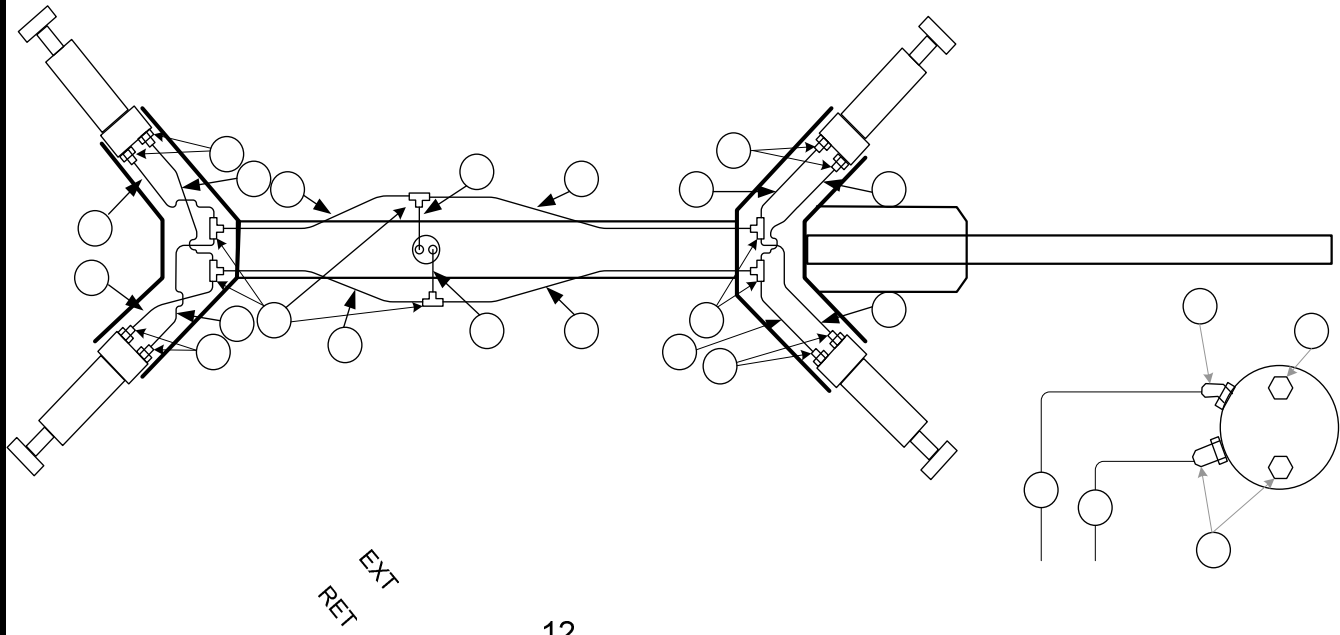

ITEM NO.	PART NUMBER	DESCRIPTION	RET	EXT	QTY.
1	B02-01-0213	# 4 x 28" Hydraulic Hose			4
2	B02-01-0214	# 4 x 28" Hydraulic Hose			4
3	B02-01-0215	# 6 x 56" Hydraulic Hose			1
4	B02-01-0216	# 6 x 56" Hydraulic Hose			1
5	B02-01-0217	# 6 x 16" Hydraulic Hose			1
6	B02-01-0218	# 6 x 16" Hydraulic Hose			1
7	B02-01-0219	# 6 x 28" Hydraulic Hose			1
8	B02-01-0220	# 6 x 28" Hydraulic Hose	RET		1
9	B02-01-0223	# 6 x 18" Hydraulic Hose		EXT	1
10	B02-01-0272	# 6 x 18" Hydraulic Hose			1
11	B02-01-0258	# 6 MORFS TEE			6
12	B02-01-0259	# 6 MORFS - # 6 MORB STRAIGHT			11
13	B02-01-0264	# 6 MORFS - # 6 MORB 45°			1

A-03182 HYDRAULIC HOSE LAYOUT - TRAILER 700° ROTATION

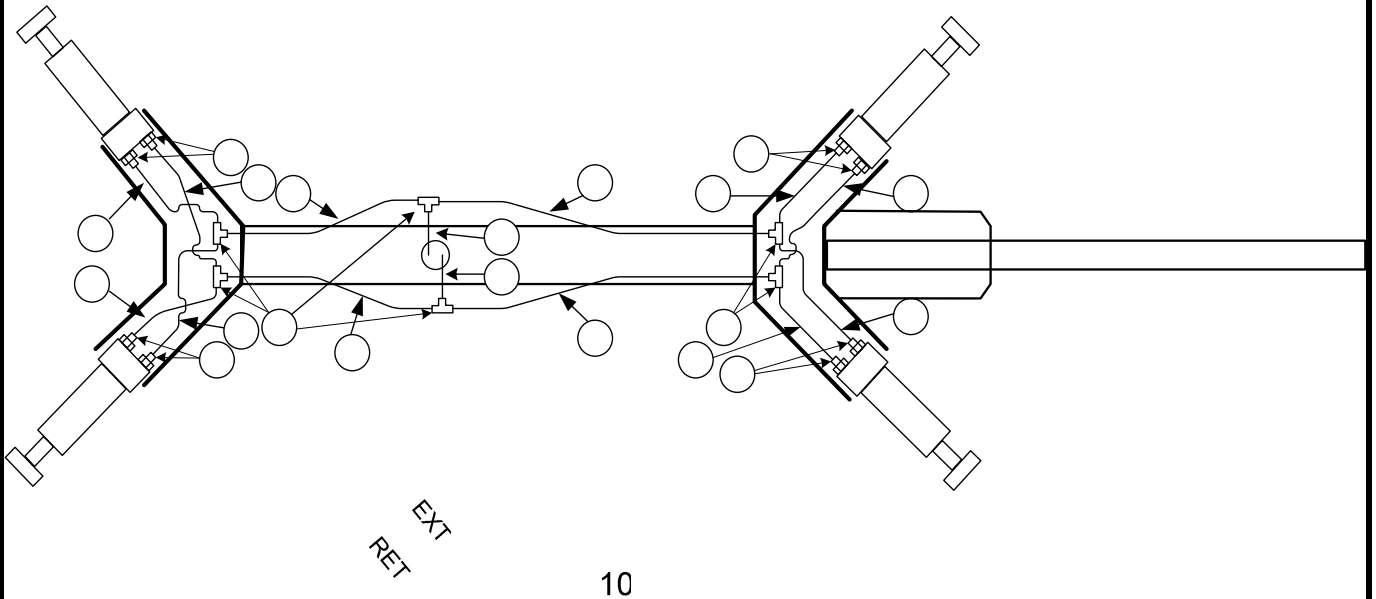

ITEM NO.	PART NUMBER	DESCRIPTION	RET	QTY
1	B02-01-0213	# 4 x 28" Hydraulic Hose		4
2	B02-01-0214	# 4 x 28" Hydraulic Hose		4
3	B02-01-0215	# 6 x 56" Hydraulic Hose	8	1
4	B02-01-0216	# 6 x 56" Hydraulic Hose		1
5	B02-01-0219	# 6 x 28" Hydraulic Hose	7	1
6	B02-01-0220	# 6 x 28" Hydraulic Hose		1
7	B02-01-0327	# 6 x 46" Hydraulic Hose		1
8	B02-01-0328	# 6 x 46" Hydraulic Hose	EXT	13
9	B02-01-0258	# 6 MORFS TEE	5	6
10	B02-01-0259	# 6 MORFS - # 6 MORB STRAIGHT		11

A-00269 HYDRAULIC HOSE LAYOUT – BOOM

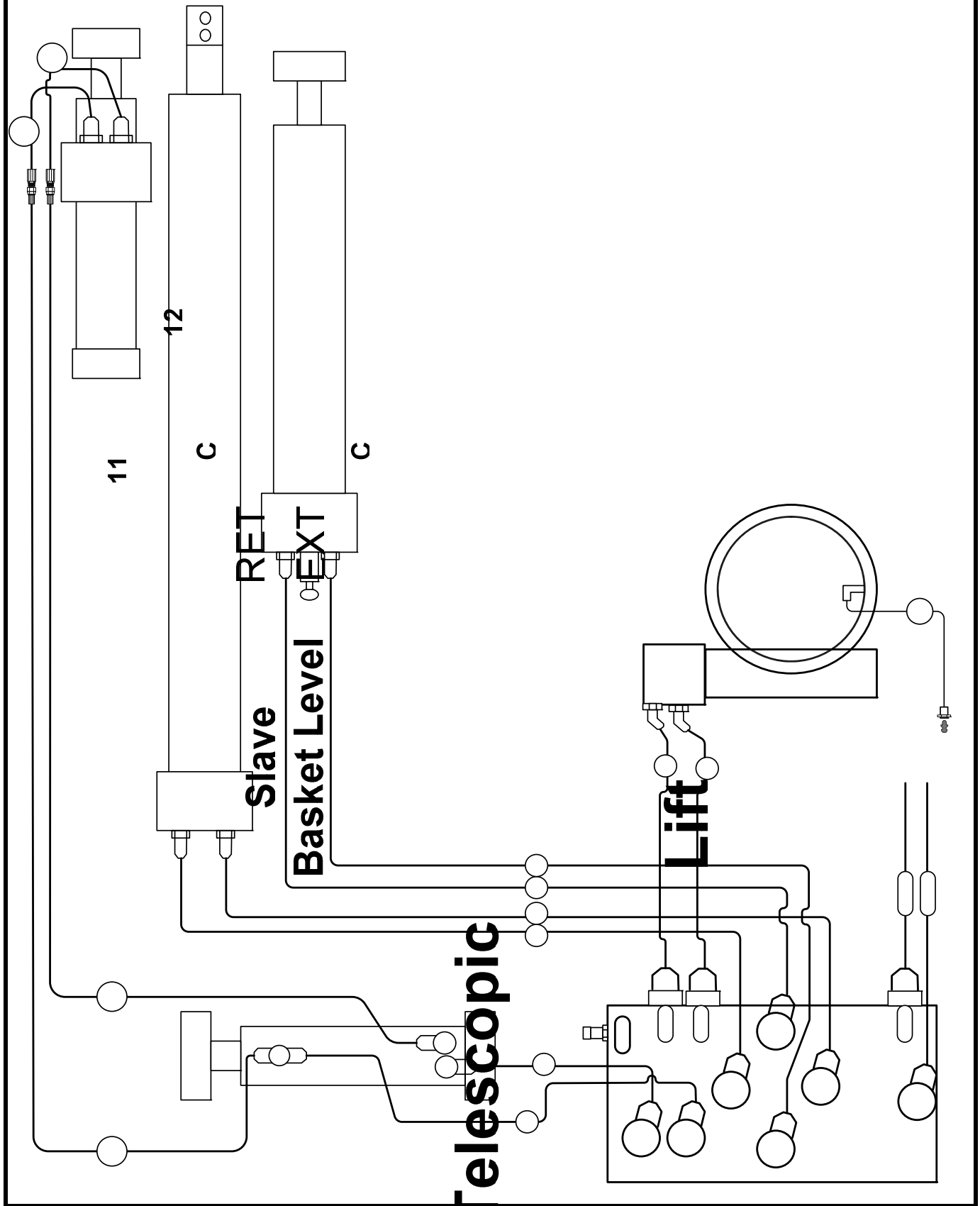

HYDRAULIC HOSE LAYOUT – BOOM

A-00269 HYDRAULIC HOSE KIT- BOOM - HOSES

ITEM NO.	PART NUMBER	DESCRIPTION	QTY.
1	B02-01-0274	# 4 x 52" Hydraulic Hose	1
2	B02-01-0275	# 4 x 42" Hydraulic Hose	1
3	B02-01-0276	# 6 x 66" Hydraulic Hose	1
4	B02-01-0277	# 6 x 66" Hydraulic Hose	1
5	B02-01-0278	# 4 x 48" Hydraulic Hose	1
6	B02-01-0279	# 4 x 48" Hydraulic Hose	1
7	B02-01-0280	# 4 x 36" Hydraulic Hose	1
8	B02-01-0281	# 4 x 36" Hydraulic Hose	1
9	B02-01-0233	# 4 x 419" Hydraulic Hose	1
10	B02-01-0232	# 4 x 427" Hydraulic Hose	1
11	B02-01-0234	# 4 x 20" Hydraulic Hose	1
12	B02-01-0235	# 4 x 20" Hydraulic Hose	1
13	B02-01-0204	# 2 x 32" Hydraulic Hose	1

A-00269F HYDRAULIC HOSE KIT- BOOM - FITTINGS

ITEM NO.	PART NUMBER	DESCRIPTION	QTY.
A	B02-02-0264	# 6 MORFS - # 6MORB 45°	8
B	B02-02-0259	# 6 MORFS - # 6 MORB STRAIGHT	6
C	B02-02-0237	# 4 MORFS - # 6 MORB STRAIGHT	2
D	B02-02-0262	# 8 MORFS - # 10 MORB 45°	2
E	B02-02-0229	# 4 MORFS - # 6 MORB 90°	2
F	B02-02-0270	# 6 MORFS - # 6 MORB - # 6 MORFS TEE	1
G	B02-02-0242	Quick Coupler, Male - # 4 MORB	1
H	B02-02-0196	1/8" MNPT - 1/8" FMNPT 90°	1
I	B02-00-0082	Hex Nut with Nylon Insert, #2	1
J	B02-00-0081	Zerk Grease	1

A-00928 MANIFOLD FOR DRIVE & SET OPTION

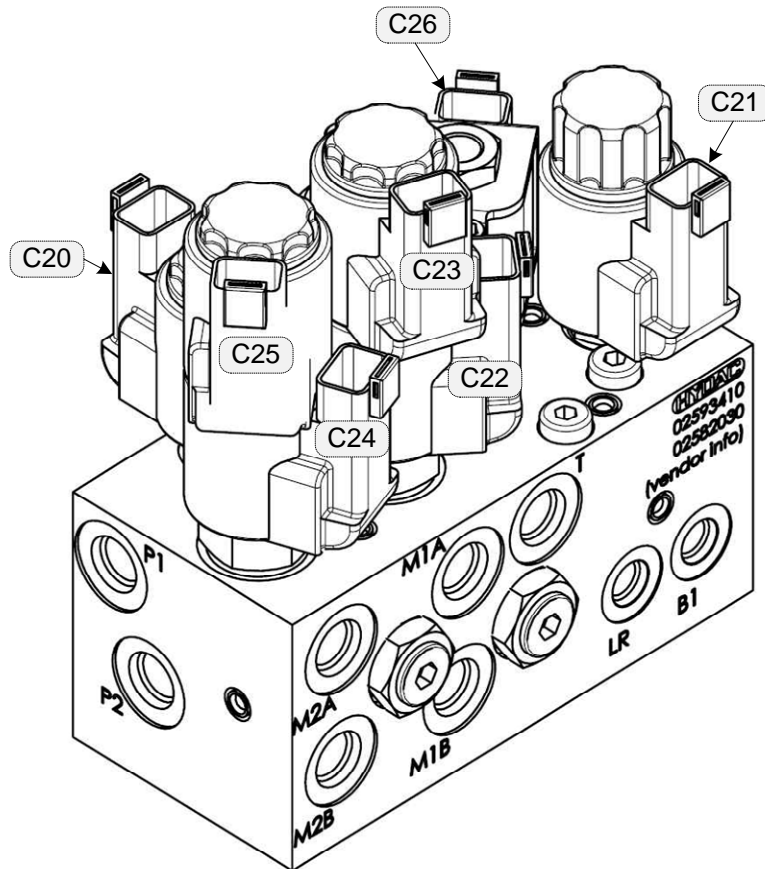
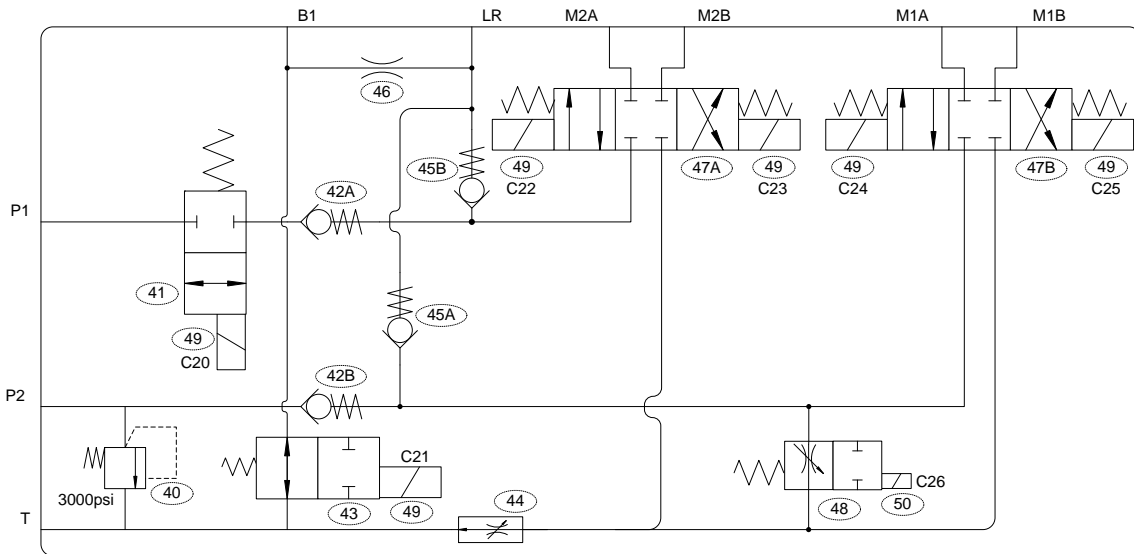

A-00928 MANIFOLD FOR DRIVE & SET OPTION

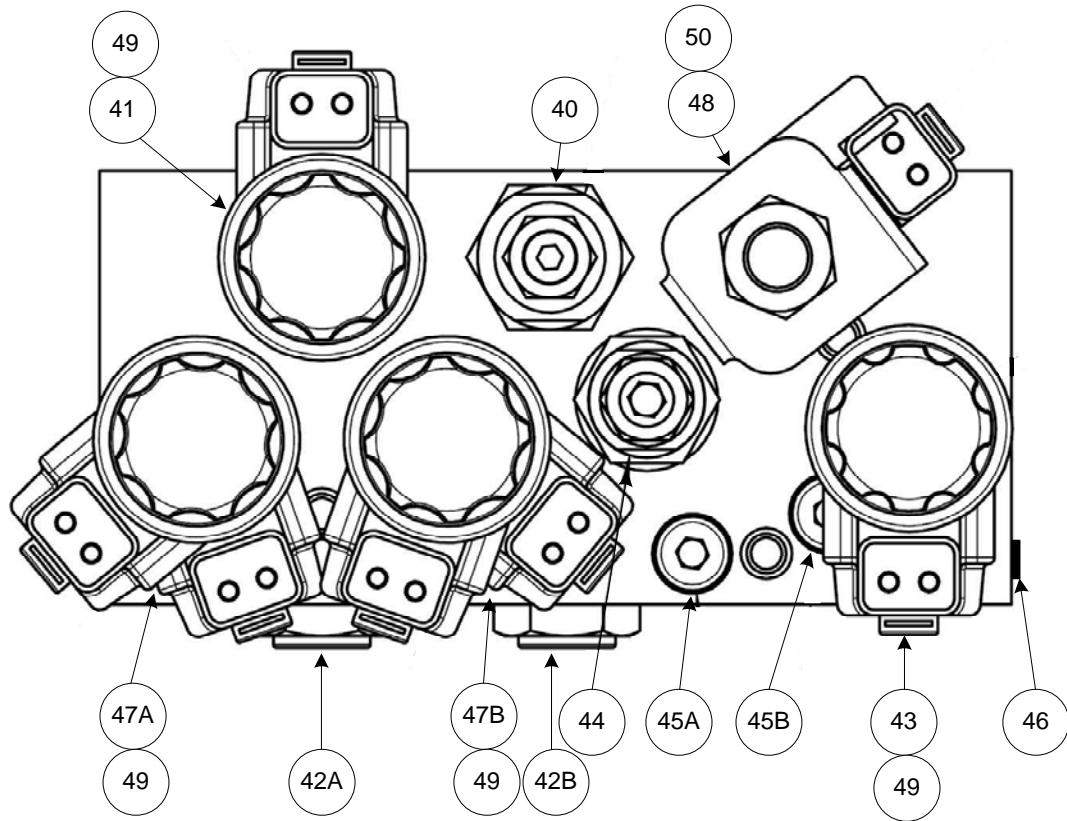

ITEM NO.	PART NUMBER	DESCRIPTION
40	B02-15-0515	Valve, Pressure Relief - 3000 PSI
41	B02-15-0516	Valve, Cart NC
42A & 42B	B02-14-0092	Valve, Check
43	B02-15-0518	Valve, Cart NO
44	B02-15-0519	Valve, Flow Control
45A & 45B	B02-15-0520	Valve, Check
46	B02-15-0521	Orifice, 1.0 mm
47A & 47B	B02-15-0522	Valve, Directional
48	B02-15-0523	Valve, Prop NO
49	B02-15-0525	Coil, 20 Volt DC Deutsch Connector
50	B02-15-0524	Coil, 20 Volt DC Deutsch Connector - Prop valve

A-00938 HYDRAULIC HOSE LAYOUT FOR DRIVE & SET OPTION

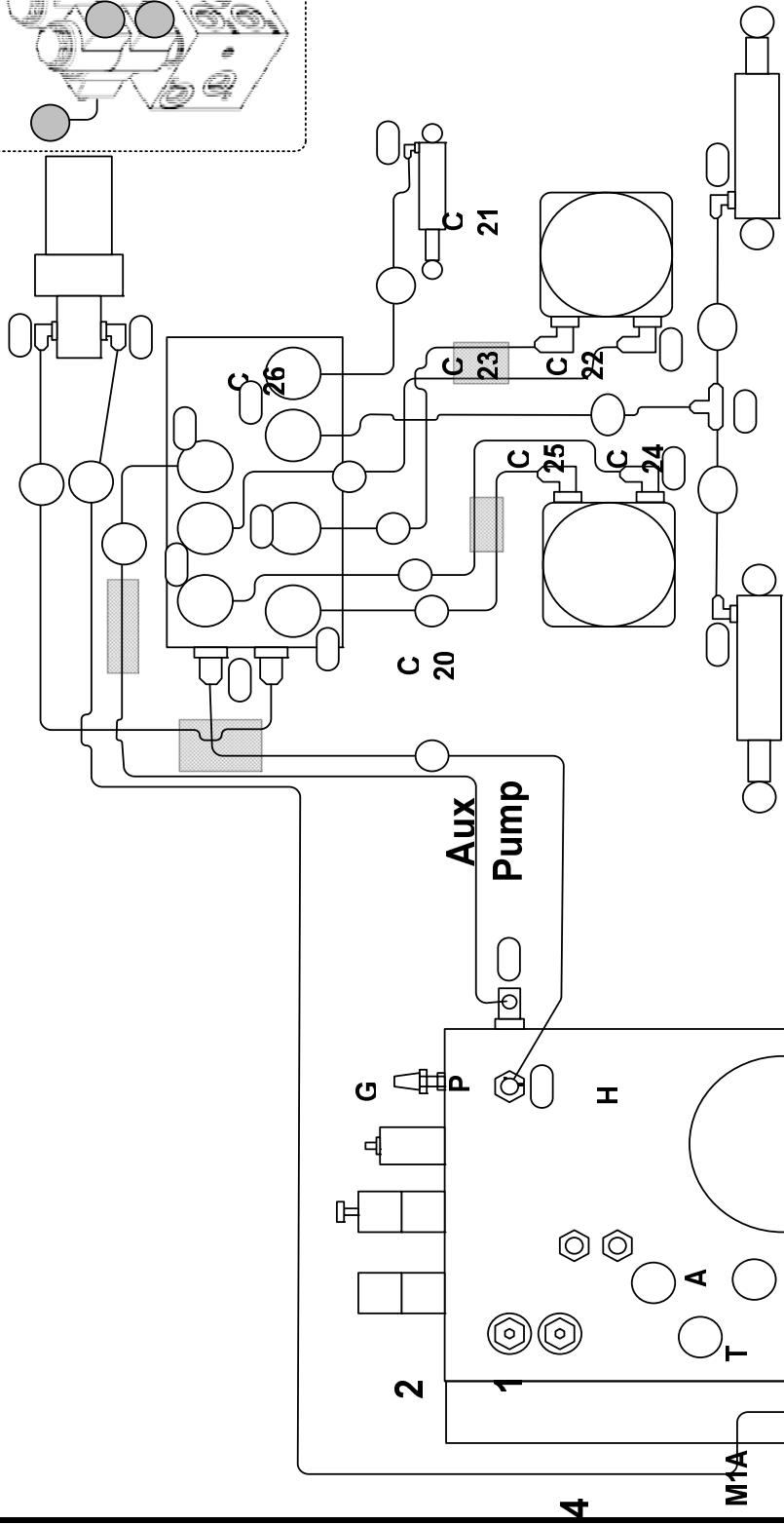
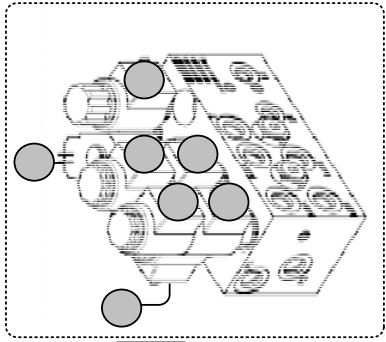

Coil Wiring

8

F

10

7

A-00938 HYDRAULIC HOSE LAYOUT FOR DRIVE & SET OPTION

ITEM NO.	PART NUMBER	DESCRIPTION	QTY.
1	B02-01-0353	# 8 x 28" Hydraulic Hose	1
2	B02-01-0347	# 6 x 80" Hydraulic Hose	1
3	B02-01-0348	# 6 x 90" Hydraulic Hose	1
4	B02-01-0370	# 6 x 90" Hydraulic Hose	1
5	B02-01-0355	# 6 x 69" Hydraulic Hose	1
6	B02-01-0356	# 6 x 69" Hydraulic Hose	1
7	B02-01-0357	# 6 x 26" Hydraulic Hose	1
8	B02-01-0358	# 6 x 26" Hydraulic Hose	1
9A	B02-01-0416	# 4 x 16" Hydraulic Hose	1
9B	B02-01-0417	# 4 x 73" Hydraulic Hose	1
10	B02-01-0373	# 4 x 30" Hydraulic Hose	1
A	B02-02-0259	# 6 MORFS - # 6 MORB STRAIGHT	8
B	B02-02-0285	# 6 MORFS - # 10 MORB 90°	4
C	B02-02-0260	# 6 MORFS - # 6 MORB 90°	2
D	B02-02-0287	# 4 MORFS - # 4 MORB STRAIGHT	2
E	B02-02-0288	# 4 MORFS - # 4 MORB 90°	3
F	B02-02-0289	# 4 MORFS - # 4 MORFS - # 4 MORFS TEE	1
G	B02-02-0301	M14 - # 6 MORFS 90°	1
H	B02-02-0302	M18 - # 8 MORFS 90°	1

A-00939 OUTRIGGER COIL TO SWITCHES FOR DRIVE & SET OPTION

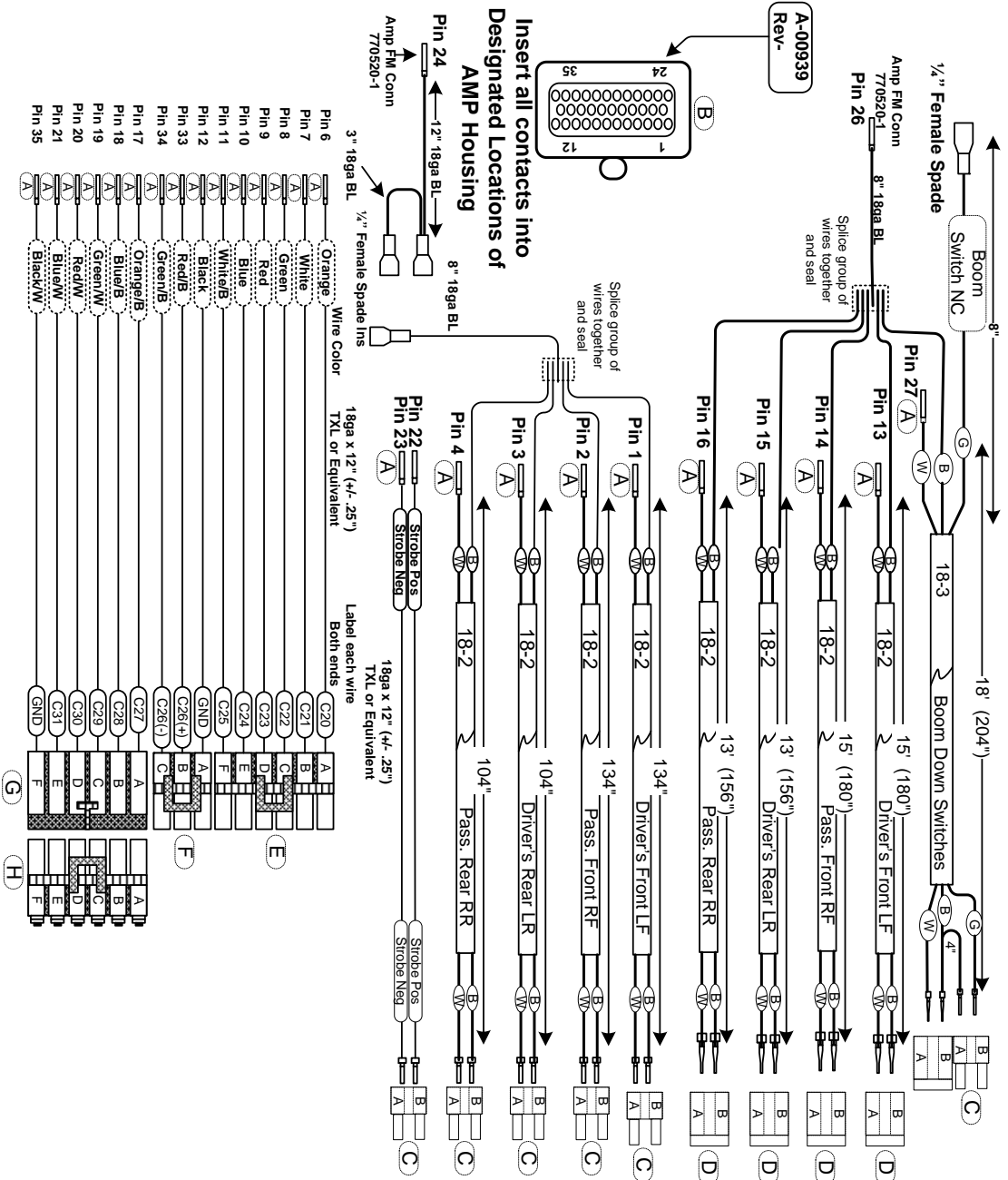

- (A) B01-09-0146 Female Terminal
- (B) B01-09-014a Plug-Black 35 Pin
- (C) B01-09-0092 2 Pin FM Housing
- (D) B01-09-0091 FM Terminal
- (E) B01-09-0093 Green Seal
- (F) B01-09-0109 2 Pin Male Housing
- (G) B01-09-0110 Male Terminal
- (H) B01-09-0128 6 Pin Female Housing
- (I) B01-09-0091 Female Terminal
- (J) B01-09-0114 3 Pin Female Housing
- (K) B01-09-0093 Green Seal
- (L) B01-09-0091 Female Terminal
- (M) B01-09-0093 Green Seal
- (N) B01-09-0129 6 Pin Male Housing
- (O) B01-09-0110 Female Terminal
- (P) B01-09-0093 Green Seal
- (Q) B01-09-0129 6 Pin Male Housing
- (R) B01-09-0128 6 Pin Female Housing

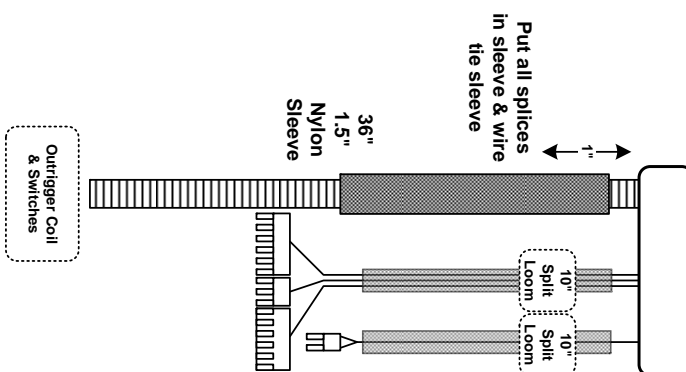

A-00947 MANIFOLD HARNESS FOR DRIVE & SET OPTION

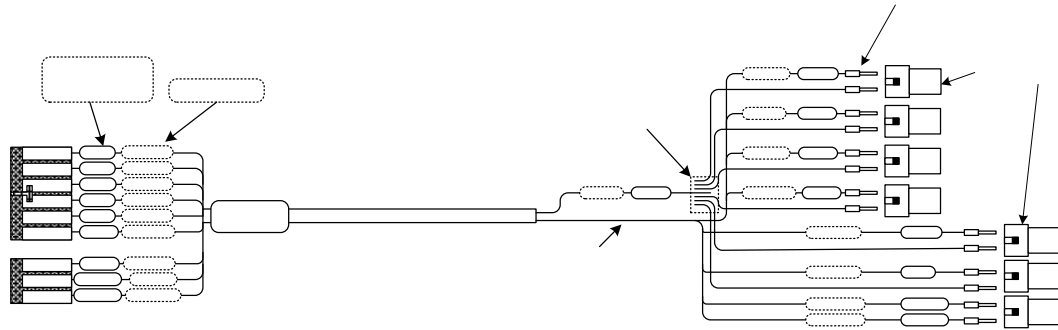

Label Wires

A-00946 BRAKE SWITCH HARNESS FOR DRIVE & SET OPTION

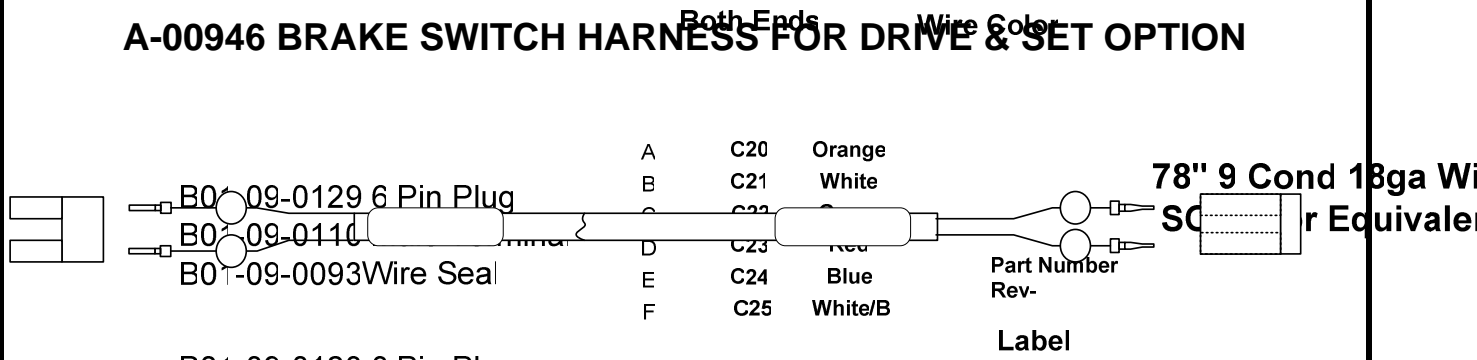

B01-09-0129 6 Pin Plug	A	GND	Black
B01-09-0110 Male Terminal	B	C26(+)	Red/B
B01-09-0093 Wire Seal	C	C26(-)	Green/B

- B01-09-0092 2 Pin FM Housing
- B01-09-0091 FM Terminal
- B01-09-0093 Green Seal

B

W

Brake Switch

19' 18-2 SJO or Equ

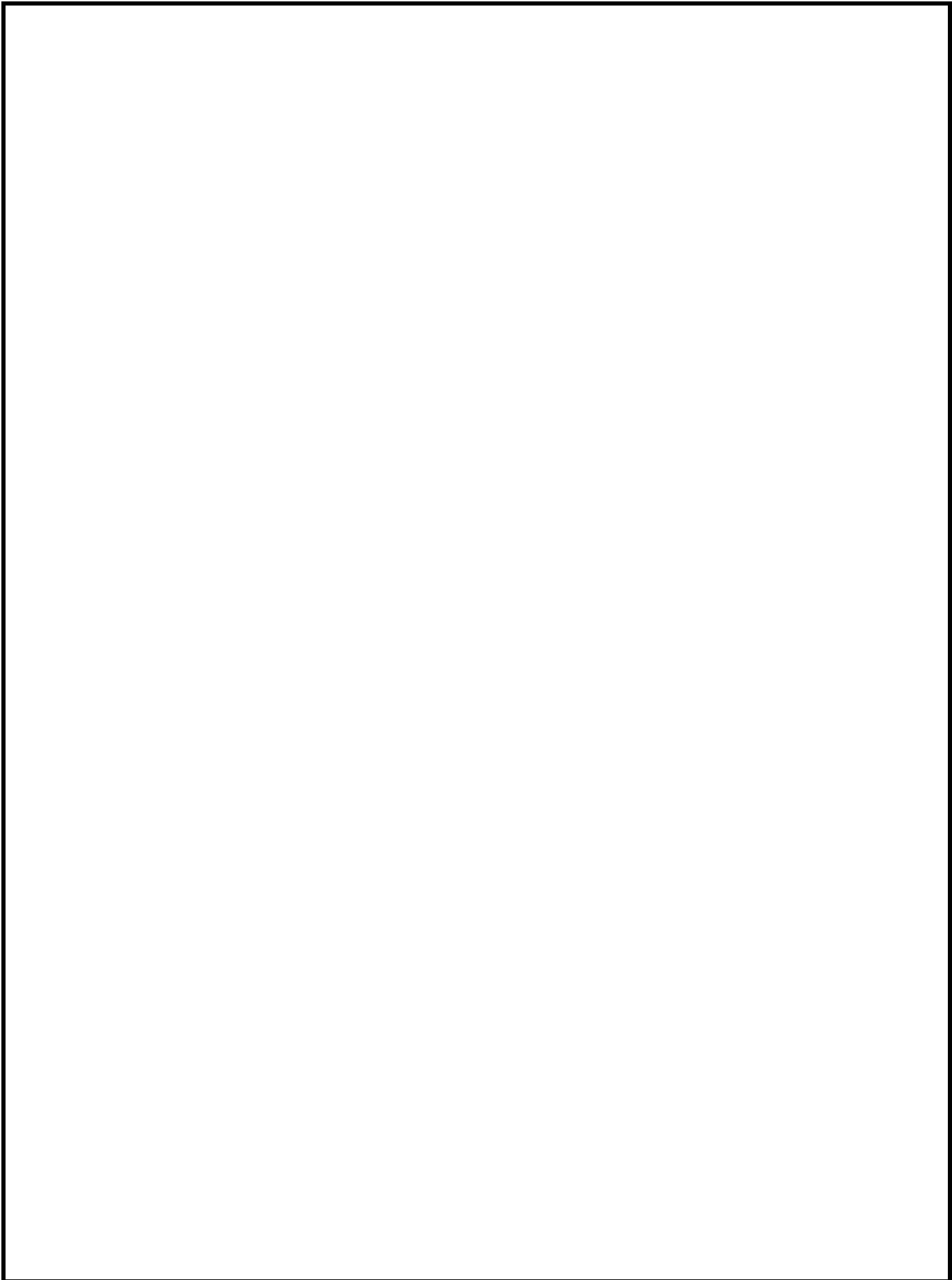

8 OPTIONAL EQUIPMENT

IC ENGINE / GENERATOR - COVER AND TRAY ASSEMBLY.....	158
IC ENGINE / GENERATOR - MOTOR MOUNT ASSEMBLY	160
IC ENGINE / GENERATOR - AC POWER HOOK-UP ASSEMBLY	116
MANUAL PLATFORM ROTATE ASSEMBLY	162
MATERIAL LIFT ASSEMBLY.....	164
MATERIAL LIFT HOOK	166
LOAD CELL CALIBRATION PROCEDURE.....	169
SWIVEL WITH 360° ROTATION.....	170

IC ENGINE / GENERATOR - COVER AND TRAY ASSEMBLY

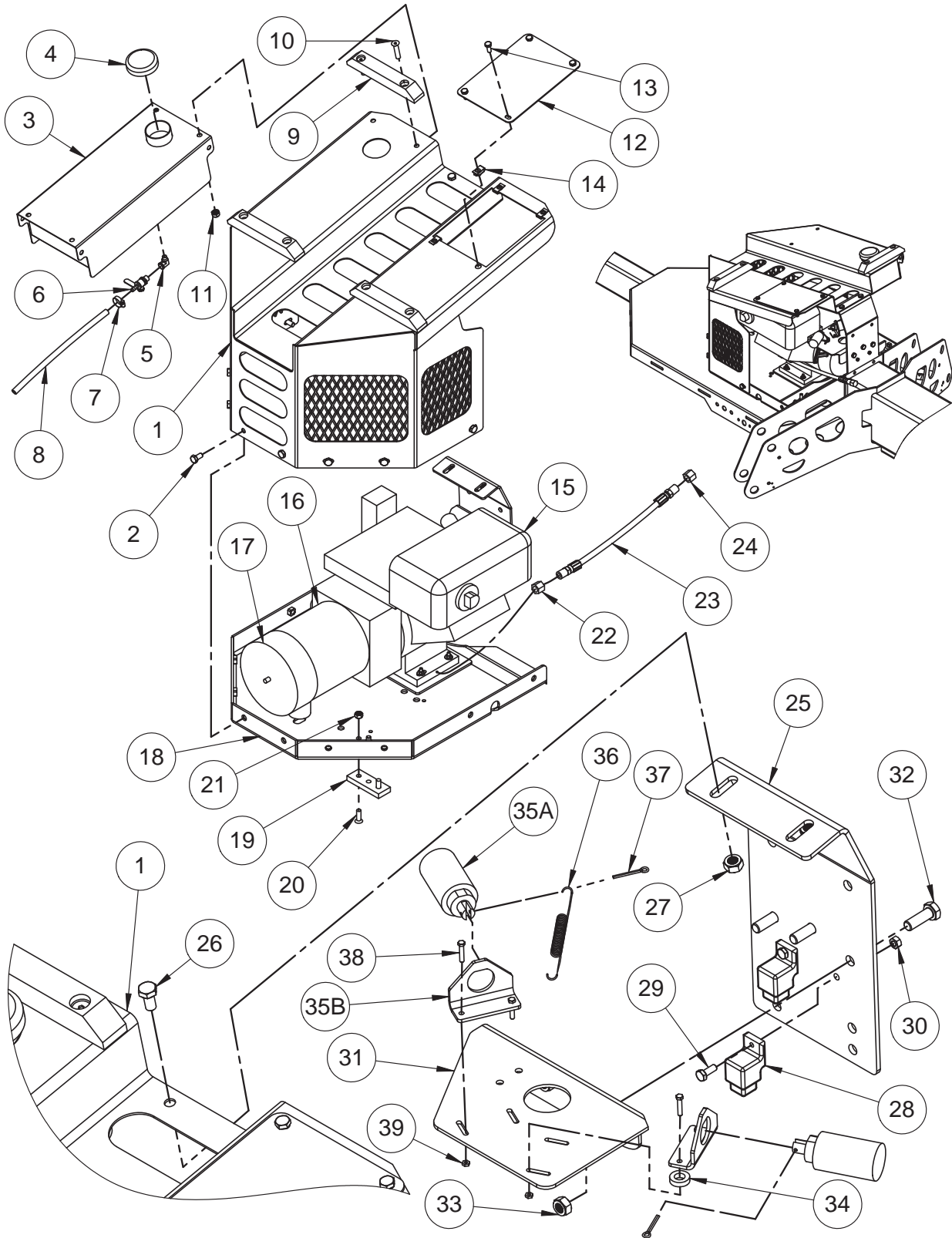

IC ENGINE / GENERATOR - COVER AND TRAY ASSEMBLY

ITEM NO.	PART NUMBER	DESCRIPTION	QTY.
1	A-01425	Cover	1
2	0096-0014	Screw, Hex Head Cap - M10 x 20	8
3	A-01428	Gas Tank, Steel	1
4	A-01434	Filler Cap, Vented - for Steel Tank	1
5	B02-02-0291	Fitting, 90° # 4 MNPT - # 4 FMNPT - Brass	1
6	B02-04-0116	Valve Ball, 1/4 HB x 1/4 MBV	1
7	B02-00-0063	Hose Clamp, #4	4
8	B20-00-0021	Fuel Line-1/4 Inch	1
9	A-01437	Pad, Cover	3
10	0096-0068	Screw, Flat Head Socket Cap - 10 x 45	6
11	0096-0041	Hex Nut with Nylon Insert - M10	6
12	A-01405	Air Filter Cover	1
13	0096-0010	Screw, Hex Head Cap - M8 x 20	4
14	0096-0067	Nut -Clip - M8	4
15	A-01407	Motor, 9 HP Tapered Shaft	1
16	A-00406	Generator, 3600 rpm - 60 Hz	1
17	A-01406	Generator Cap	1
18	A-01410	Tray	1
19	A-01421	Pad	4
20	0096-0092	Screw, Flat Head Socket Cap - M10 x 30	8
21	0096-0041	Hex Nut with Nylon Insert - M10	8
22	B02-02-0181	Fitting, Engine Oil Drain - Not Shown	1
23	B02-01-0001	Hose, Hydraulic - # 4 x 15.0 inch #4NPTM	1
24	B02-02-0182	Fitting, Cap - Hex # 4 NPT	1
25	A-01420	Bracket	1
26	0096-0016	Screw, Hex Head Cap - M10 x 25	2
27	0096-0041	Hex Nut with Nylon Insert - M10	2
28	B01-06-0053	Relay, 24 VDC 20 Amp	2
29	0096-0125	Screw, Hex Head Cap - M5 x 16	2
30	0096-0126	Hex Nut with Nylon Insert - M5	2
31	A-00419	Mount, Solenoid	1
32	0096-0017	Screw, Hex Head Cap - M10 x 30	3
33	0096-0041	Hex Nut with Nylon Insert - M10	3
34	0096-0047	Washer, Nylon - M10	2
35	A-01408	Solenoid Bracket	1
35A	A-00410A	Solenoid Assembly, 24Volt	2
35B	A-00410	Solenoid, 24Volt - Continuous Duty	1
35C	B00-00-0170	Wire Casing - Not Shown	0.5
35D	B01-09-0092	Connector Assembly, 2 Female - Not Shown	1
34E	B01-09-0091	Terminal, Female - 16/18 Gauge - Not Shown	2
35F	B01-09-0093	Seal, Wire - 16/18 Gauge - Green - Not Shown	2
36	B39-00-0020	Spring, Tension	1
37	0090-0144	Pin, Cotter - 3/32 x 3/4	2
38	0096-0074	Screw, Hex Head Cap - M4 x 20	4
39	0096-0073	Hex Nut with Nylon Insert - M4	4

IC ENGINE / GENERATOR - MOTOR MOUNT ASSEMBLY

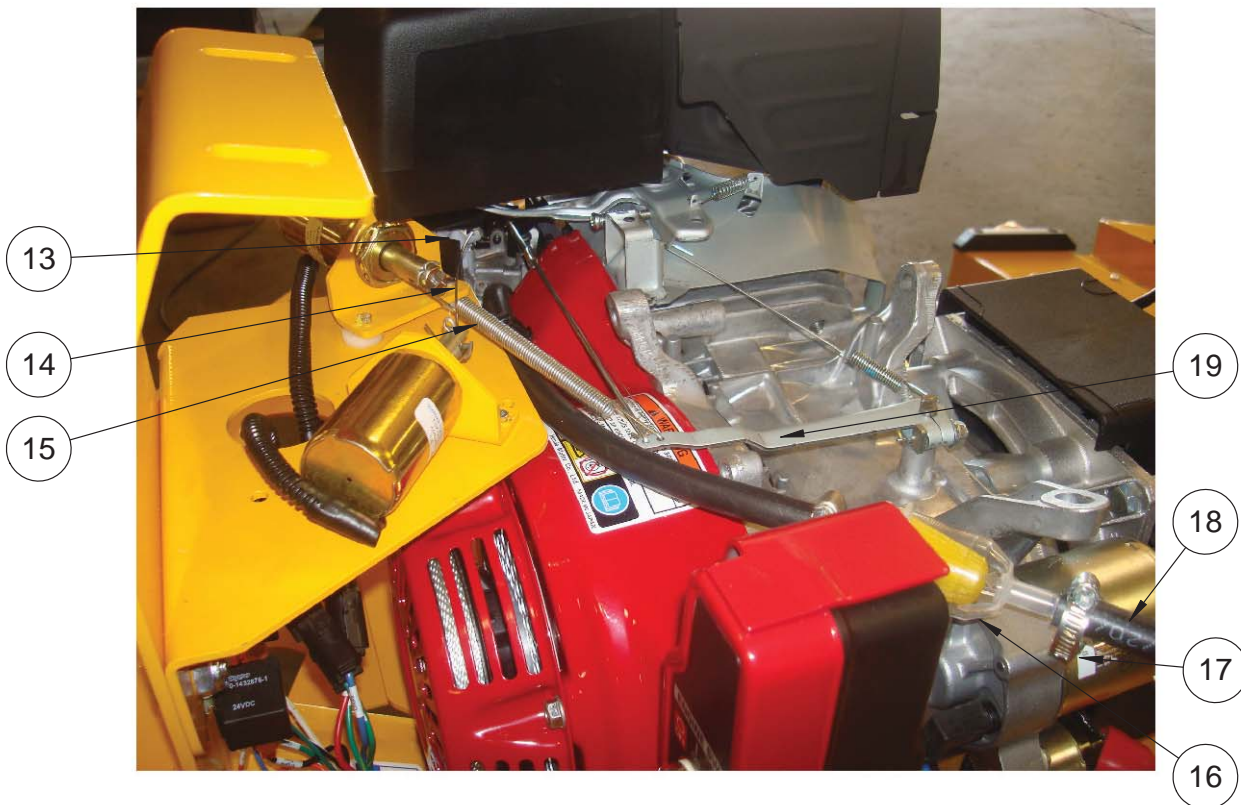
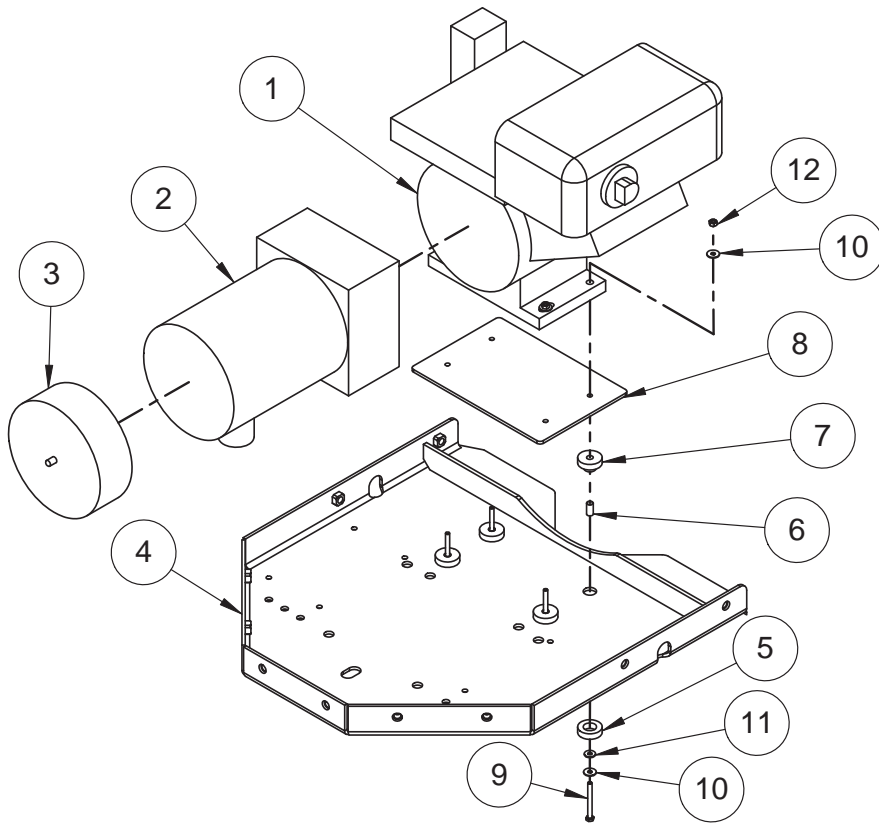

IC ENGINE / GENERATOR - MOTOR MOUNT ASSEMBLY

ITEM NO.	PART NUMBER	DESCRIPTION	QTY.
1	A-01407	Motor, 9 HP Tapered Shaft	Ref.
2	A-00406	Generator, 3600 rpm - 60 Hz	Ref.
3	A-01406	Generator Cap	Ref.
4	A-01410	Tray	Ref.
5	B20-00-0006	Mount Ring	4
6	B07-10-1263	Tube, .375 x .049 x .750	4
7	B20-00-0007	Mount Bushing	4
8	B07-06-5198	Plate	1
9	0096-0085	Screw, Hex Head Cap - M6 x 60	4
10	0096-0077	Flat Washer, M6 - Large	8
11	0096-0076	Flat Washer, M12 - Large	4
12	0096-0039	Hex Nut with Nylon Insert - M6	4
13	-	Choke Arm - Part of Engine	1
14	B20-00-0018	Wire, Choke Linkage - .051 gauge	1
15	B39-00-0020	Spring, Tension	1
16	B20-00-0017	Fuel Filter, Inline - 1/4 inch Ends	1
17	B02-00-0063	Hose Clamp, #4	4
18	B20-00-0021	Fuel Line-1/4 Inch	1
19	-	Governor Arm - Part of Engine	1
20	A-00413	Linkage Spring - Not Shown	1
21	B01-09-0130	Wire splice, T-Tap - 18 - 14 gauge - Not Shown	2

MANUAL PLATFORM ROTATE ASSEMBLY

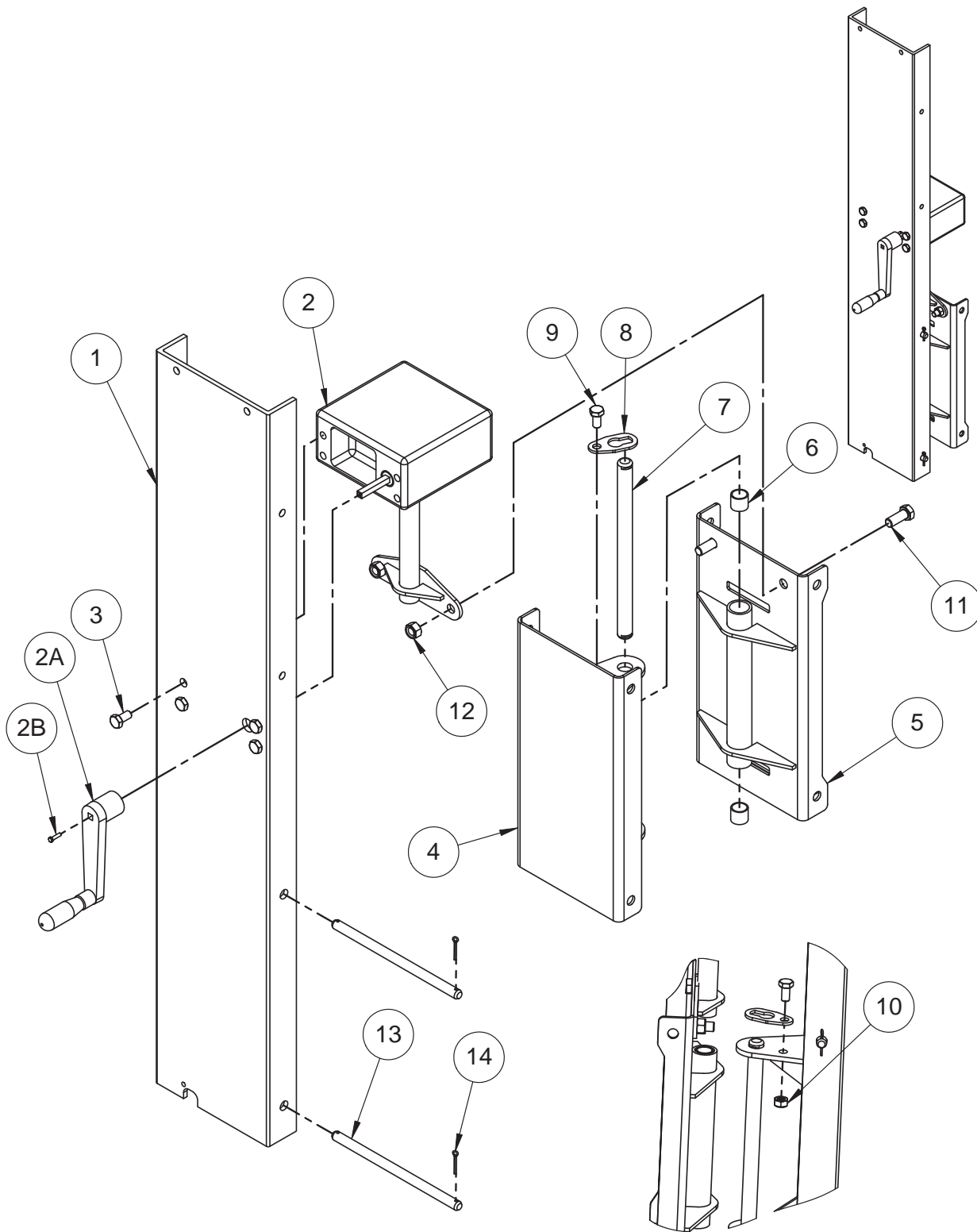

DETAIL VIEW

MANUAL PLATFORM ROTATE ASSEMBLY

ITEM NO.	PART NUMBER	DESCRIPTION	QTY.
	A-00300	Manual Platform Rotator Assembly	1
1	A-00449	Platform Assembly	Ref.
2	A-00315	Gearbox	1
2A	A-00340	Crank Handle - Square Shaft Replaces A-00325 - Round Shaft Effective 2010	1
2B	-	Bolt - Supplied with Gear Box	1
3	0096-0014	Screw, Hex Head Cap M10 x 20	4
4	A-00308	Platform Rotate Mount Weldment	1
5	A-00301	Platform Rotate Mount A Weldment	1
6	A-00330	Bearing, .75 ID x .75 Long x .125 Thick	2
7	A-00329	Pin, .75 x 10.75	1
8	A-00017	Pin Retainer, .75	2
9	0096-0014	Screw, Hex Head Cap - M10 x 20	2
10	0096-0041	Hex Nut with Nylon Insert, M10	2
11	0096-0019	Screw, Hex Head Cap - M12 x 25	2
12	0096-0042	Hex Nut with Nylon Insert, M12	2
13	A-00071	Pin, .5 x 8.875	2
14	0090-0147	Pin, Cotter - 1/8 x 1 1/4	4

MATERIAL LIFT ASSEMBLY

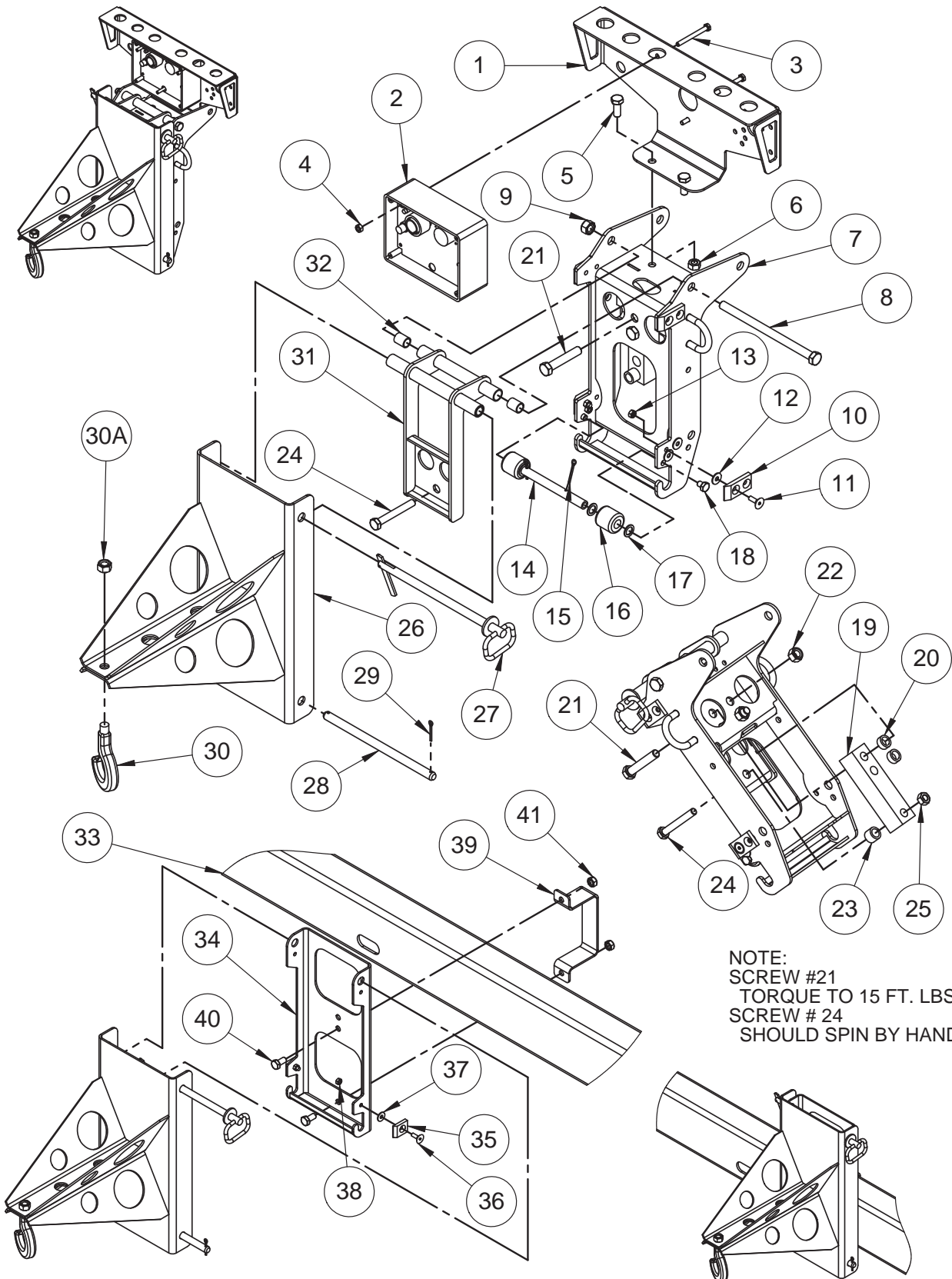

MATERIAL LIFT ASSEMBLY

ITEM NO.	PART NUMBER	DESCRIPTION	QTY.
	A-00846	Material Lift Package	1
1	A-00979	Bulkhead Mount	Ref.
2	A-00992	Load Sense Interface Module	1
3	0096-0085	Screw, Hex Head Cap - M6 x 60	3
4	0096-0039	Hex Nut with Nylon Insert - M6	3
5	0096-0016	Screw, Hex Head Cap - M10 x 25	2
6	0096-0041	Hex Nut with Nylon Insert, M10	2
7	A-00977	Platform Mount Weldment – LS	1
8	0096-0055	Screw, Hex Head Cap - M12 X 190	1
9	0096-0042	Hex Nut with Nylon Insert - M12	1
10	A-00038	Ramp	4
11	0096-0003	Screw, Flat Head Socket Cap - M6 x 20	8
12	0096-0077	Flat Washer, M6	8
13	0096-0039	Hex Nut with Nylon Insert - M6	8
14	A-00994	Load Sense Roller Bar	1
15	0090-0147	Cotter Pin, 1/8 x 1 1/4	2
16	A-00995	Load Sense Roller	2
17	0096-0046	Flat Washer, M12	4
18	0096-0009	Screw, Hex Head Cap - M8 x 10	2
19	A-00988-1	Load Cell With Turck Connector	1
20	A-00990B	Load Sense Spacer B	2
21	0096-0086	Screw, Hex Head Cap - M12 x 65 - Torque to 15 Ft. Lbs.	2
22	0096-0042	Hex Nut with Nylon Insert - M12	2
23	A-00990A	Load Sense Spacer A	1
24	0096-0069	Screw, Hex Head Cap - M10 x 75 - Bolt should Spin by Hand	1
25	0096-0041	Hex Nut with Nylon Insert, M10	1
26	A-00480	Material Boom Weldment	1
27	A-00028	Clevis Pin with Tension Lock	1
28	A-00071	Pin, 0.5" x 8.875"	1
29	0090-0147	Cotter Pin, 1/8 x 1 1/4	2
30	A-00485	Hook with Latch	1
30A	-	Castle Nut – supplied with Hook	1
30B	0090-0147	Cotter Pin, 1/8 x 1 1/4 - Not Shown	1
31	A-00982	Load Sense Weldment	1
32	A-00033	Bearing, Composite - .50 x .625 x .75	4
33	A-00170	Tongue Tube	Ref.
34	A-00155	Material Lift Storage Bracket	1
35	A-00037	Ramp - Short	4
36	0096-0003	Screw, Flat Head Socket Cap - M6 x 20	4
37	0096-0077	Flat Washer, M6	2
38	0096-0039	Hex Nut with Nylon Insert - M6	4
39	A-00156	Material Storage Clamp	1
40	0096-0016	Screw, Hex Head Cap - M10 x 25	2
41	0096-0041	Hex Nut with Nylon Insert, M10	2
42	0090-0552	Key Ring - Not Shown	1

MATERIAL LIFT HOOK

If the aerial work platform is equipped with a Material Lifting Hook, observe the following procedure for material lift operation:

- Remove the Platform Control Box from the work platform by releasing the latch on the back of the control box.
- Disconnect the Platform Control Box from the Load Sense Module located on the Boom Lift Bulkhead.
- Disconnect the electric loopback plug from the receptacle on the bottom right of the Ground Control Box and insert it into the Platform Control Box. See Figures 8-1 & 8-2.

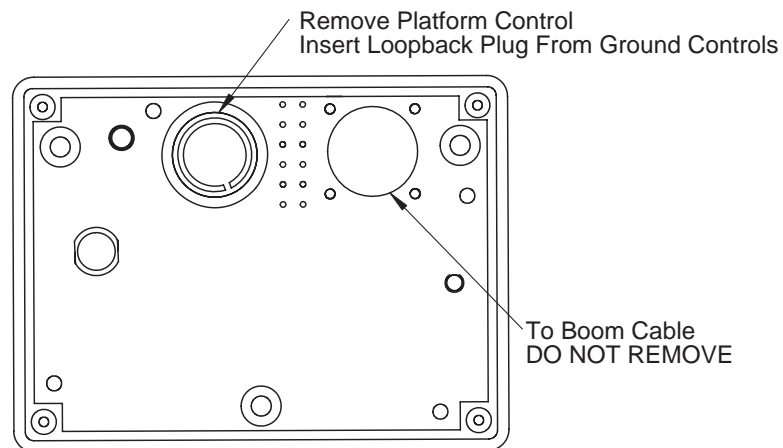

Figure 8-1. Load Sense Module

Loopback Plug
Remove and replace
with Platform Controls Plug.



Figure 8-2. Ground Control Panel Receptacle

- Insert the removed electric loopback plug into the open receptacle on the load sense module, replacing the platform control cable.

MATERIAL LIFT HOOK (CONTINUED)

- Firmly secure the platform to prevent equipment damage.
- Remove the clevis pin holding the platform to the boom lift. See Figure 8-3
- Remove the platform from the boom by lifting the cage up and away from the mounting bracket on the boom nose. See Figure 8-3.

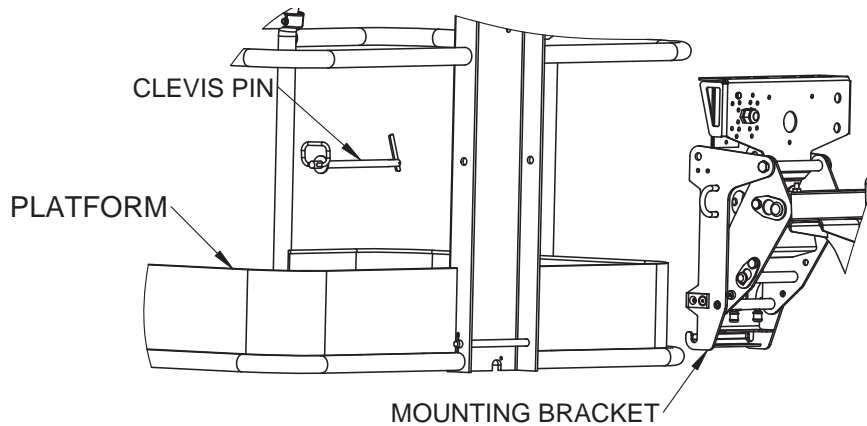

Figure 8-3. Platform Removal

- Attach the material lifting hook to the mounting bracket on the boom nose and re-insert the clevis pin. See Figure 8-4.
- Verify that the Key Switch is in the correct position for operation using the Platform Control Box.
- For optimal control operate the material lifting hook remotely, using the Platform control box.
- Reverse this procedure to reattach the Work Platform.

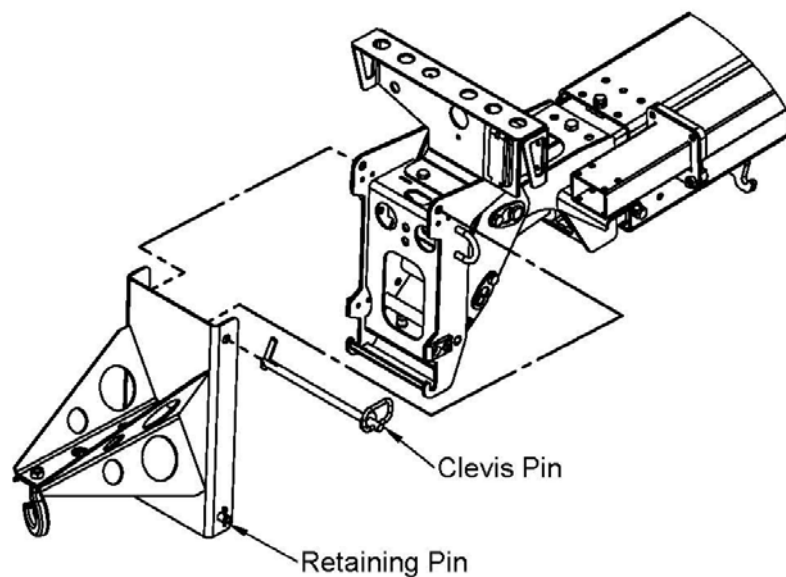

Figure 8-4. Material Lifting Hook Installation

MATERIAL LIFT HOOK (CONTINUED)

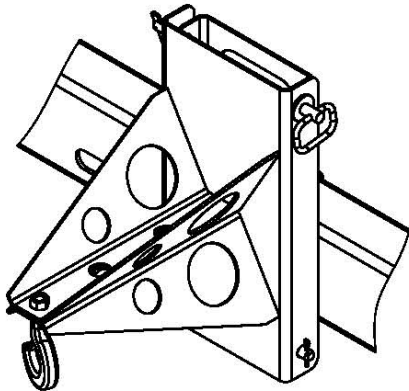

Figure 8-5. Material Lift "Stowed" Position

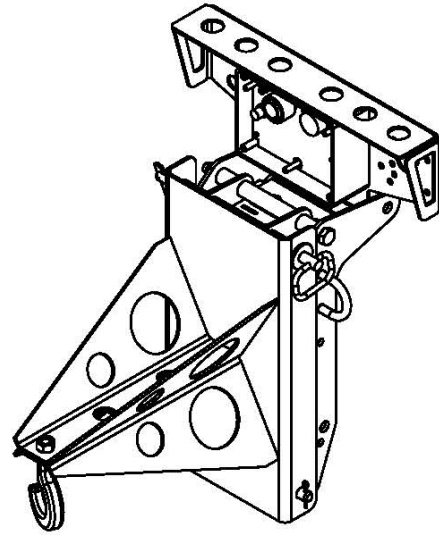

Figure 8-6. Material Lift "In Use" Position

WARNING

ALWAYS observe the manufacturer's weight lifting limitations when using the material lifting hook. Always use lifting straps or wire rope slings that are rated at a minimum 500 lbs. lifting capacity. **NEVER** stand beneath an elevated load or position an elevated load above personnel. Falling objects could cause death or serious injury.

DANGER

This aerial work platform is not insulated for use near electrical power lines and **DOES NOT** provide protection from contact with or close proximity to any electrically charged conductor. Operator must maintain safe clearances at all times and always allow for platform movement such as wind-induced sway. Refer to Table 1-1 for minimum safe approach distances between the aerial work platform and electrical power lines.

LOAD CELL CALIBRATION PROCEDURE

- 1) Remove the clevis pin securing the basket to the platform mount bracket.
- 2) Enter the maintenance mode by pressing both rotate keys and the outrigger extend key on the lower control panel simultaneously and holding for 5 seconds.
- 3) Scroll through the maintenance menu using the turtle key until "Load Sense Zero Calibration Utility" is found.
- 4) Press both mid speed keys on the lower control panel simultaneously. Three consecutive beeps will sound and the display will read "Load Sense Has Been Zero Calibrated" confirming the operation. The maintenance mode will then go to "Load Sense Scaling Utility".
- 5) In "Load Sense Scaling Utility", the display should read a ratio of "3.68:1=0". If the ratio is not "3.68:1", proceed to Step 6. If the ratio is correct, but load is not "=0", skip Step 6 and proceed to Step 7. If both the ratio and the load are correct, proceed to Step 8.
- 6) If the ratio is not "3.68:1", press the mid-high or mid-low speed key until the ratio is correct. Proceed to Step 7.
- 7) Press the rabbit key to return to "Load Sense Zero Calibration Utility" and repeat Steps 4 and 5. The Display should now read "3.68:1=0". If so, proceed to Step 8.
- 8) Exit the maintenance mode by scrolling through the menu using the turtle key. Press the "Basket Compensate Up and Down" simultaneously until the display reads "Boom Load=0000 lbs/kg".
- 9) Return the basket to the upright position and re-install the clevis pin with tension lock. The display should now read 65lbs/30kg (+/-10%).

Note: The display should read 125lbs/57kg for lifts with the Platform Rotate option.

- 10) Add between 350-400lbs/159-182kg to basket.

Note: Keep accurate track of how much weight (within + or - 5lbs/2.3kg) is going into the basket.

- 11) The "Boom Load" on the display should read the added weight plus the initially displayed weight (+/-10%).

Minimum Load = 0.9 (W1 + W2)

Maximum Load = 1.1 (W1 + W2)

Where W1 = Initial displayed weight and W2 = Added Weight.

- 12) If displayed load is within tolerances, proceed to Step 14. If not, return to maintenance mode, scroll **PAST** "Load Sense Zero Calibration Utility" and proceed directly to "Load Sense Scaling Utility".
- 13) Adjust displayed weight by pressing mid-high or mid-low speed until weight is within tolerances, exit maintenance mode. The Ratio should be within **3.50:1** to **4.00:1**. If so, continue on to Step 14. If the ratio is **not** within the above values, contact Haulotte Group Customer Service Department: 1-888-440-9240.
- 14) Remove weight from basket. The Boom Load should now return to the initially displayed weight from Step 9
- 15) Return weight to the basket. The Boom Load should read the same weight as the weight recorded in step 11.
- 16) Repeat steps 14 and 15. Remove the weight, and turn the machine off.
- 17) Turn the machine back on, the display should return to the weight displayed in Step 9.
- 18) Repeat steps 14 and 15 twice making sure that Boom Load is reading properly.
- 19) Operate all functions in all speeds from both upper and lower controls to verify proper operation.
- 20) Recalibration is complete.

SWIVEL WITH 360° ROTATION

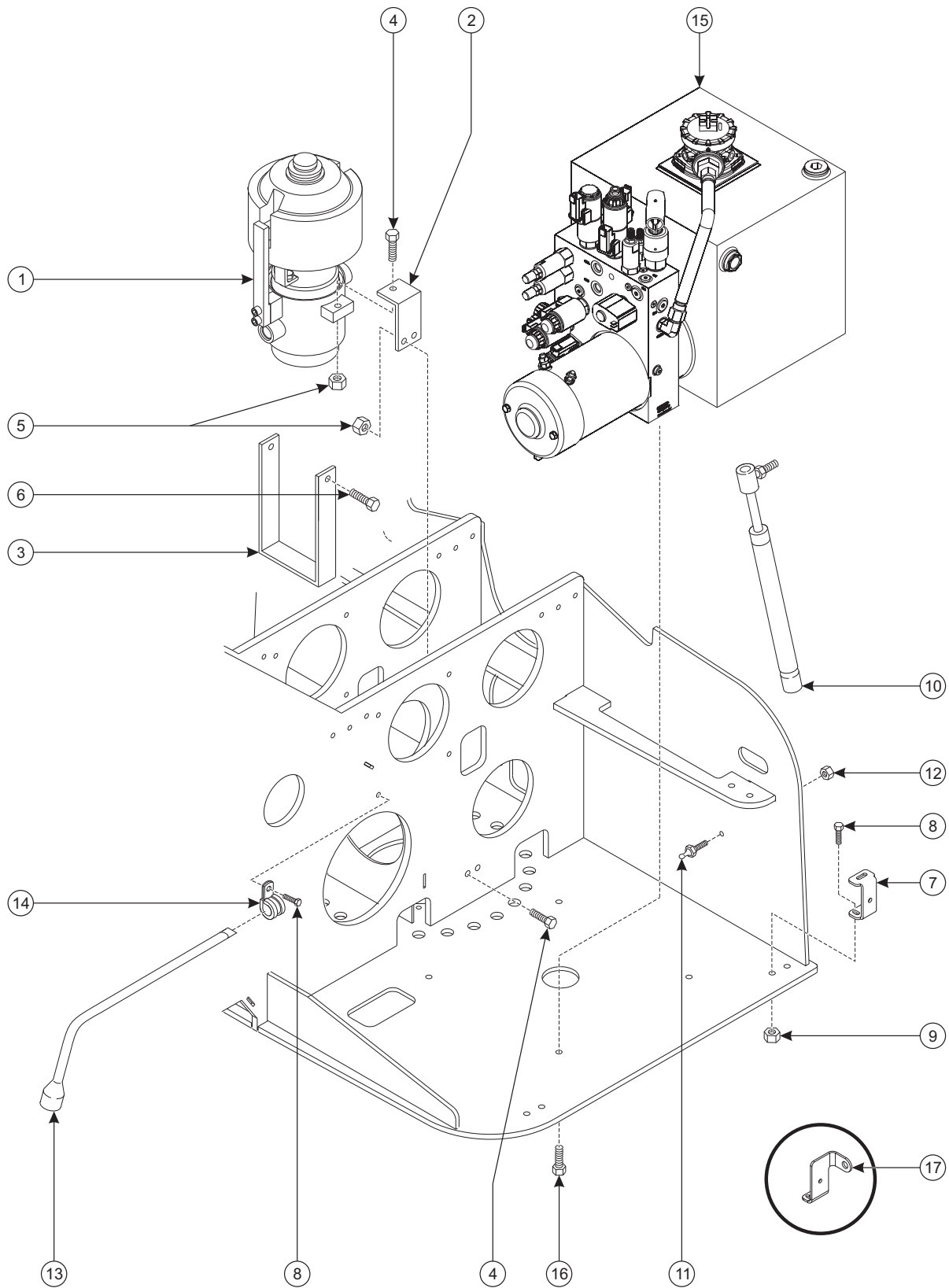

SWIVEL WITH 360° ROTATION

ITEM NO.	PART NUMBER	DESCRIPTION	QTY.
1	A-00257	Swivel – Hydraulic/Electric	1
1A	B02-13-0144	Seal kit	1
1B	B02-16-0017	Hydraulic Pressure Kit	1
2	A-00265	Slip Ring Mount	2
3	A-00266	Slip Ring Collar	1
4	0096-0011	Cap Screw, M8 x 25	6
5	0096-0040	Hex Nut, Self-Locking, M8	6
6	0090-0040	Cap Screw, #3/8-16 x 3/4	2
7	A-00290	Cover Stop Bracket	1
8	0096-0002	Cap Screw, M6 x 20	4
9	0096-0039	Hex Nut, Self-Locking, M6	4
10	A-00274	Gas Spring	1
11	0090-0920	Ball Stud, 10MM	2
12	0090-0185	Hex Nut, Self-Locking, #5/16-18	2
13	A-00268	Tire Iron/Jack Handle	1
14	B04-07-0033	Clamp	2
15	A-00254	Hydraulic Power Unit	1
16	0096-0014	Cap Screw, M10 x 20	3
17	A-00277R	Cover Stop Bracket Hasp – Right (Alternate)	1

*Optional Swivel provides 360° Rotation and includes item numbers 1-6, above.

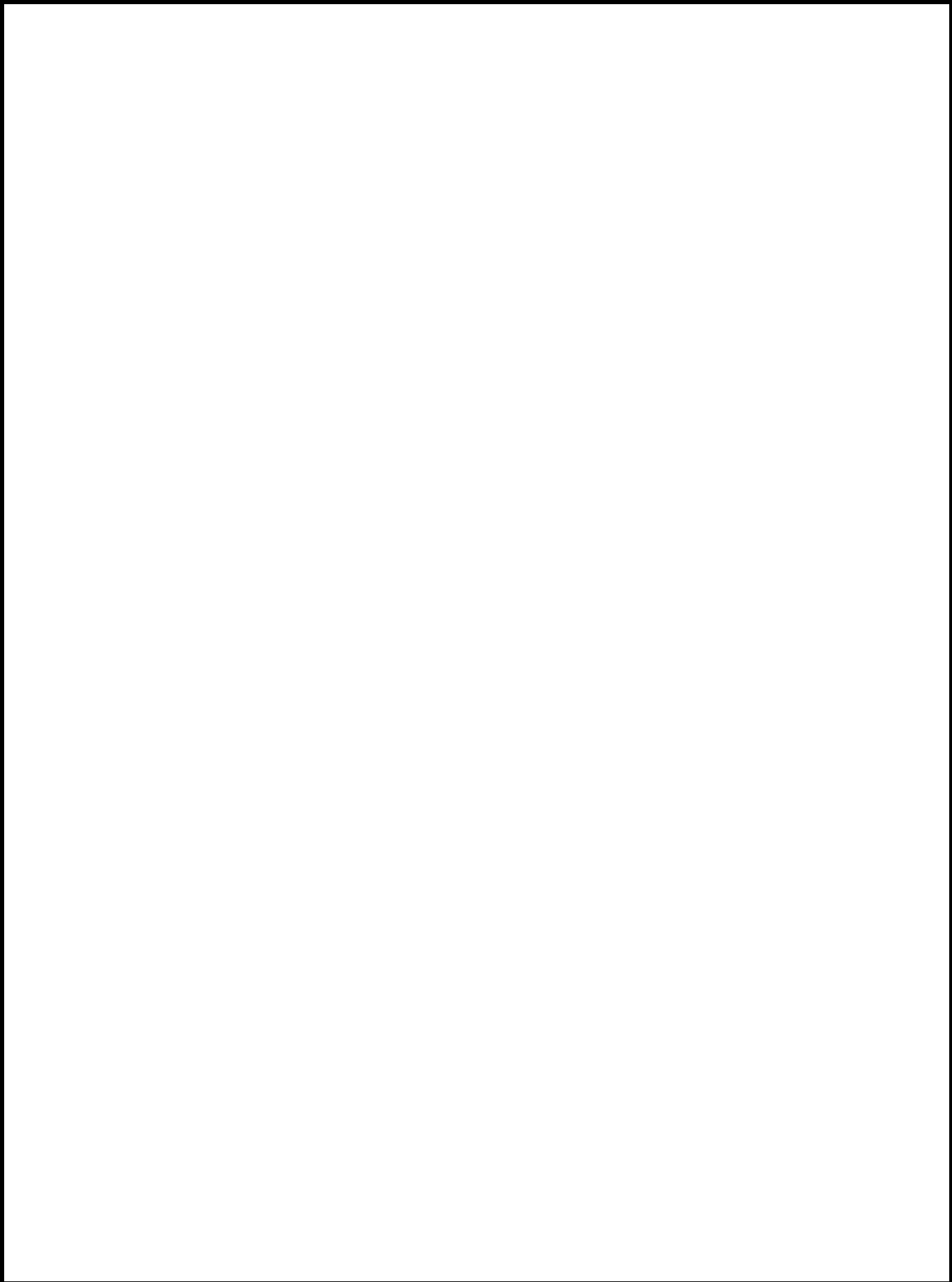

9 MATERIAL SAFETY

The following Material Safety Data Sheets describe the correct procedures for the safe handling of chemical components within the Model 3632T / HTT 13 Telescoping Boom Lift, as well as any potential health and safety hazards related to these chemicals. Material Safety Data Sheets are included here in accordance with applicable federal and state regulations. Read and observe all safety precautions. Maintain awareness of potential health and safety hazards.

MATERIAL SAFETY DATA SHEET FOR LEAD ACID BATTERIES, WET, FILLED WITH ACID

SECTION I – GENERAL INFORMATION					
Manufacturer's Name:	Crown Battery Mfg. Company	EMERGENCY NO: 800 487-2879			
Street Address:	1445 Majestic Drive	OR		800 OIL-TANK	
City, State, Zip	Fremont, Ohio 43420				
Phone Number:	419 334-7181	REVISION DATE: 5/18/2000			
SECTION II -- MATERIAL IDENTIFICATION AND INFORMATION					
COMPONENTS	PERCENT	OSHA PEL	ACGIH TLV	OTHER LIMITS	CAS NUMBER
Hazardous Components 1% or greater Carcinogens 0.01% or greater					
METALLIC LEAD METAL	25.5%	0.05 mg/m3	0.05 mg/m3	NONE	7439-92-1
LEAD SULFATES	18.2%	0.05 mg/m3	0.05 mg/m3	NONE	7439-92-1
LEAD OXIDES	18.0%	0.05 mg/m3	0.05 mg/m3	NONE	7439-92-1
POLYPROPYLENE CASE MTL	6.4%				
SEPARATORS	3.5%				
SULFURIC ACID (H2SO4)	5.2%	1.0 mg/m3	1.0 mg/m3	NONE	7664-93-9
WATER	19.2%				
REGULATORY INFORMATION:	Those ingredients listed above are not subject to the reporting requirements of 313 of Title III of the Superfund Amendments and Reauthorization Act. The items are covered in an exemption as a "Manufactured Article". 372.30(b)				
SECTION III -- PHYSICAL / CHEMICAL CHARACTERISTICS					
Boiling Point	Approximately 203F	Vapor Density:	Greater Than 1		
Vapor Pressure	14 @ 37% @ 80 F	Melting Point:	-36 F to -10.6 F		
Solubility in Water	100%	Water Reactive:	Yes, Produces Heat		
Specific Gravity	1.245 - 1.295 Battery Electrolyte				
Appearance & Odor	Clear Liquid with Sharp Pungent Odor				
SECTION IV -- FIRE AND EXPLOSION HAZARD DATA					
Flash Point:	Not Combustible				
Auto Ignition Temperature	N/A	Flammability Limits in Air % by Volume:	N/A		
Extinguishing Media:	Dry Chemical Carbon Dioxide, Water Fog, Water				
Special Fire Fighting Procedures:	Sulfuric Acid Fumes, Sulfur Dioxide Gas or Carbon Monoxide may be released when acid decomposes. Wear NIOSH approved self-contained breathing apparatus.				
Unusual Hazards:	Water applied to sulfuric acid generates heat and causes acid to splatter. Wear full-cover acid resistant clothing. Sulfuric acid reacts violently with metals, nitrates, chlorates, carbides, fulminates, picrates and other organic materials. Reacts with most metals to yield explosive/flammable hydrogen gas. This reaction is intensified when sulfuric acid is diluted with water to form battery electrolyte.				

MATERIAL SAFETY DATA SHEET

FOR LEAD ACID BATTERIES, WET, FILLED WITH ACID (CONTINUED)

SECTION V -- HEALTH HAZARD DATA

Primary Routes of Entry:	Inhalation: YES Skin: YES Ingestion: YES
Health Hazards:	Acute EYES, SKIN, RESPIRATORY SYSTEM & DIGESTIVE SYSTEM Chronic: EYES, SKIN, RESPIRATORY SYSTEM & DIGESTIVE SYSTEM
Signs and Symptoms of Exposure:	IRRITATION OF EXPOSED AREA, BURNS AND RESPIRATORY PROBLEMS NO POSSIBILITY OF EXPOSURE OF LEAD WILL OCCUR UNLESS BATTERY IS DESTROYED.
Medical Conditions Generally Aggravated By Exposure:	EXPOSURE TO MIST MAY CAUSE LUNG DAMAGE & AGGRAVATE PULMONARY CONDITION.
Emergency First Aid Procedures:	SEEK MEDICAL ASSISTANCE FOR FURTHER TREATMENT, OBSERVATION AND SUPPORT IF NECESSARY.
Eye Contact:	WASH WITH COPIOUS QUANTITIES OF COOL WATER FOR AT LEAST 15 MINUTES
Skin Contact:	FLUSH AREA WITH LARGE AMOUNTS OF COOL WATER FOR AT LEAST 15 MINUTES
Inhalation:	REMOVE TO FRESH AIR, IF BREATHING IS DIFFICULT - GIVE OXYGEN
Ingestion:	GIVE MILK TO DRINK, <u>DO NOT</u> INDUCE VOMITING. CALL PHYSICIAN

SECTION VI -- REACTIVITY DATA

Stability:	STABLE	Conditions to Avoid: N/A
Incompatibility:	AVOID COMBUSTIBLES, ORGANIC MATERIALS, AND STRONG REDUCING AGENTS	
Hazardous Decomposition Products:	SULFUR TRIOXIDE, CARBON MONOXIDE, SULFURIC ACID FUMES, & SULFUR DIOXIDE	
Hazardous Polymerization:	MAY OCCUR	Conditions to Avoid: N/A

SECTION VII -- SPILL OR LEAK PROCEDURES

Steps to be taken in case material is released or spilled:
CONTAIN SPILL, USING NON-COMBUSTIBLE MATERIALS: VERMICULITE, DRY SAND & EARTH. NEUTRALIZE WITH LIME, SODA ASH, SODIUM BICARBONATE, ETC.

Waste disposal method: CONSULT STATE ENVIRONMENTAL AGENCY. INDIVIDUAL STATE REGULATIONS VARY

Precautions to be taken in Handling & Storage: SEPARATE FROM INCOMPATIBLE MATERIALS, KEEP AWAY FROM FIRE, SPARKS AND HEAT

Other Precautions and/or Special Hazards:
CONTACT WITH METALS MAY PRODUCE TOXIC SULFUR DIOXIDE FUMES & MAY ALSO RELEASE FLAMMABLE HYDROGEN GAS. THIS REACTION IS INTENSIFIED WHEN DILUTED.

NFPA Rating:	HEALTH: 3	FLAMMABILITY: 0	REACTIVITY: 2	SPECIAL: 0
HMIS Rating:	HEALTH: 3	FLAMMABILITY: 0	REACTIVITY: 2	PERSONAL PROTECTION: X

SECTION VIII -- CONTROL AND PROTECTIVE MEASURES

Respiratory Protection:	ABOVE P.E.L.: NIOSH APPROVED, FITTED, FULL FACE RESPIRATOR
Protective Gloves:	ACID RESISTANT
Eye Protection:	FULL FACE PROTECTION
Ventilation:	LOCAL EXHAUST: VENTILATED AREA PREFERRED MECHANICAL: IF BELOW P.E.L. SPECIAL: MUST BE ACID & EXPLOSIVE RESISTANT OTHER: MUST BE ACID & EXPLOSIVE RESISTANT
Other Protective Equipment:	ACID RESISTANT CLOTHING AND BOOTS
Hygienic Work Practices:	N/A

MATERIAL SAFETY DATA SHEET

POWERFLOW™ AW HVI HYDRAULIC OIL



Powerflow™ AW HVI Hydraulic Oil (All Grades)

Material Safety Data Sheet

1. Product and Company Identification

Product Name:	Powerflow™ AW HVI Hydraulic Oil (All Grades)
MSDS Number:	814636
Synonyms:	Powerflow™ AW HVI Hydraulic Oil 32 Powerflow™ AW HVI Hydraulic Oil 46 Powerflow™ AW HVI Hydraulic Oil 68
Intended Use:	Hydraulic Fluid
Manufacturer/Supplier:	ConocoPhillips Lubricants 600 N. Dairy Ashford, 2W900 Houston, Texas 77079-1175
Emergency Health and Safety Number:	Chemtrec: 800-424-9300 (24 Hours)
Customer Service:	U.S.: 800-822-6457 or International: +1-83-2486-3363
Technical Information:	800-766-0050
MSDS Information:	Internet: http://w3.conocophillips.com/NetMSDS/

2. Hazards Identification

Emergency Overview

This material is not considered hazardous according to OSHA criteria.

NFPA



Appearance: Clear and bright

Physical Form: Liquid

Odor: Petroleum

Potential Health Effects

Eye: Contact may cause mild eye irritation including stinging, watering, and redness.

Skin: Contact may cause mild skin irritation including redness and a burning sensation. Prolonged or repeated contact can defat the skin, causing drying and cracking of the skin, and possibly dermatitis (inflammation). No harmful effects from skin absorption are expected.

Inhalation (Breathing): No information available on acute toxicity.

Ingestion (Swallowing): Low degree of toxicity by ingestion.

Signs and Symptoms: Effects of overexposure may include irritation of the digestive tract, nausea and diarrhea. Inhalation of oil mist or vapors at elevated temperatures may cause respiratory irritation.

Pre-Existing Medical Conditions: Conditions which may be aggravated by exposure include skin disorders.

See Section 11 for additional Toxicity Information.

814636 - Powerflow™ AW HVI Hydraulic Oil (All Grades)

Date of Issue:

Page 1/7

Status: Final

MATERIAL SAFETY DATA SHEET

POWERFLOW™ AW HVI HYDRAULIC OIL (CONTINUED)

814636 - Powerflow™ AW HVI Hydraulic Oil (All Grades)

Page 2/7

Date of Issue: 14-Nov-2008

Status: Final

3. Composition / Information on Ingredients

Component	CASRN	Concentration*
Lubricant Base Oil (Petroleum)	VARIOUS	>90
Additives	PROPRIETARY	<10

* All concentrations are percent by weight unless ingredient is a gas. Gas concentrations are in percent by volume.

4. First Aid Measures

Eye Contact: If irritation or redness develops from exposure, flush eyes with clean water. If symptoms persist, seek medical attention.

Skin Contact: Remove contaminated shoes and clothing and cleanse affected area(s) thoroughly by washing with mild soap and water or a waterless hand cleaner. If irritation or redness develops and persists, seek medical attention.

Inhalation (Breathing): If respiratory symptoms develop, move victim away from source of exposure and into fresh air in a position comfortable for breathing. If symptoms persist, seek medical attention.

Ingestion (Swallowing): First aid is not normally required; however, if swallowed and symptoms develop, seek medical attention.

Notes to Physician: High-pressure hydrocarbon injection injuries may produce substantial necrosis of underlying tissue despite an innocuous appearing external wound. These injuries often require extensive emergency surgical debridement and all injuries should be evaluated by a specialist in order to assess the extent of injury. Early surgical treatment within the first few hours may significantly reduce the ultimate extent of injury.

Acute aspirations of large amounts of oil-laden material may produce a serious aspiration pneumonia. Patients who aspirate these oils should be followed for the development of long-term sequelae. Inhalation exposure to oil mists below current workplace exposure limits is unlikely to cause pulmonary abnormalities.

5. Fire-Fighting Measures

NFPA 704 Hazard Class

Health: 0 Flammability: 1 Instability: 0 (0-Minimal, 1-Slight, 2-Moderate, 3-Serious, 4-Severe)

Unusual Fire & Explosion Hazards: This material may burn, but will not ignite readily. If container is not properly cooled, it can rupture in the heat of a fire.

Extinguishing Media: Dry chemical, carbon dioxide, foam, or water spray is recommended. Water or foam may cause frothing of materials heated above 212°F. Carbon dioxide can displace oxygen. Use caution when applying carbon dioxide in confined spaces.

Fire Fighting Instructions: For fires beyond the initial stage, emergency responders in the immediate hazard area should wear protective clothing. When the potential chemical hazard is unknown, in enclosed or confined spaces, a self contained breathing apparatus should be worn. In addition, wear other appropriate protective equipment as conditions warrant (see Section 8).

Isolate immediate hazard area and keep unauthorized personnel out. Stop spill/release if it can be done safely. Move undamaged containers from immediate hazard area if it can be done safely. Water spray may be useful in minimizing or dispersing vapors and to protect personnel. Cool equipment exposed to fire with water, if it can be done safely. Avoid spreading burning liquid with water used for cooling purposes.

Hazardous Combustion Products: Combustion may yield smoke, carbon monoxide, and other products of incomplete combustion. Oxides of sulfur, nitrogen or phosphorus may also be formed.

See Section 9 for Flammable Properties including Flash Point and Flammable (Explosive) Limits

6. Accidental Release Measures

MATERIAL SAFETY DATA SHEET

POWERFLOW™ AW HVI HYDRAULIC OIL (CONTINUED)

814636 - Powerflow™ AW HVI Hydraulic Oil (All Grades)
Date of Issue: 14-Nov-2008

Page 3/7
Status: Final

6. Accidental Release Measures

Personal Precautions: This material may burn, but will not ignite readily. Keep all sources of ignition away from spill/release. The use of explosion-proof electrical equipment is recommended. Stay upwind and away from spill/release. Notify persons down wind of the spill/release, isolate immediate hazard area and keep unauthorized personnel out. Wear appropriate protective equipment, including respiratory protection, as conditions warrant (see Section 8). See Sections 2 and 7 for additional information on hazards and precautionary measures.

Environmental Precautions: Stop spill/release if it can be done safely. Prevent spilled material from entering sewers, storm drains, other unauthorized drainage systems, and natural waterways. Use water sparingly to minimize environmental contamination and reduce disposal requirements. Spills into or upon navigable waters, the contiguous zone, or adjoining shorelines that cause a sheen or discoloration on the surface of the water, may require notification of the National Response Center (phone number 800-424-8802).

Methods for Containment and Clean-Up: Notify relevant authorities in accordance with all applicable regulations. Immediate cleanup of any spill is recommended. Dike far ahead of spill for later recovery or disposal. Absorb spill with inert material such as sand or vermiculite, and place in suitable container for disposal.

7. Handling and Storage

Precautions for safe handling: Wash thoroughly after handling. Use good personal hygiene practices and wear appropriate personal protective equipment.

High pressure injection of hydrocarbon fuels, hydraulic oils or greases under the skin may have serious consequences even though no symptoms or injury may be apparent. This can happen accidentally when using high pressure equipment such as high pressure grease guns, fuel injection apparatus or from pinhole leaks in tubing of high pressure hydraulic oil equipment.

Do not enter confined spaces such as tanks or pits without following proper entry procedures such as ASTM D-4276 and 29CFR 1910.146. Do not wear contaminated clothing or shoes.

"Empty" containers retain residue and may be dangerous. Do not pressurize, cut, weld, braze, solder, drill, grind, or expose such containers to heat, flame, sparks, or other sources of ignition. They may explode and cause injury or death. "Empty" drums should be completely drained, properly bunged, and promptly shipped to the supplier or a drum reconditioner. All containers should be disposed of in an environmentally safe manner and in accordance with governmental regulations. Before working on or in tanks which contain or have contained this material, refer to OSHA regulations, ANSI Z49.1, and other references pertaining to cleaning, repairing, welding, or other contemplated operations.

Conditions for safe storage: Use and store this material in cool, dry, well-ventilated area away from heat and all sources of ignition. Keep container(s) tightly closed. Store only in approved containers. Keep away from any incompatible material (see Section 10). Protect container(s) against physical damage.

8. Exposure Controls / Personal Protection

Component	US-ACGIH	OSHA	Other
Lubricant Base Oil (Petroleum)	TWA: 5mg/m ³ STEL: 10 mg/m ³ as Oil Mist, if generated	TWA: 5 mg/m ³ as Oil Mist, if generated	---

Note: State, local or other agencies or advisory groups may have established more stringent limits. Consult an industrial hygienist or similar professional, or your local agencies, for further information.

Engineering controls: If current ventilation practices are not adequate to maintain airborne concentrations below the established exposure limits, additional engineering controls may be required.

Eye/Face Protection: The use of eye protection that meets or exceeds ANSI Z.87.1 is recommended to protect against potential eye contact, irritation, or injury. Depending on conditions of use, a face shield may be necessary.

Skin/Hand Protection: The use of gloves impervious to the specific material handled is advised to prevent skin contact. Users should check with manufacturers to confirm the breakthrough performance of their products. Suggested protective materials: Nitrile.

MATERIAL SAFETY DATA SHEET

POWERFLOW™ AW HVI HYDRAULIC OIL (CONTINUED)

814636 - Powerflow™ AW HVI Hydraulic Oil (All Grades)
 Date of Issue: 14-Nov-2008

Page 4/7
 Status: Final

Respiratory Protection: Where there is potential for airborne exposure above the exposure limit a NIOSH certified air purifying respirator equipped with R or P95 filters may be used.

A respiratory protection program that meets or is equivalent to OSHA 29 CFR 1910.134 and ANSI Z88.2 should be followed whenever workplace conditions warrant a respirator's use. Air purifying respirators provide limited protection and cannot be used in atmospheres that exceed the maximum use concentration (as directed by regulation or the manufacturer's instructions), in oxygen deficient (less than 19.5 percent oxygen) situations, or under conditions that are immediately dangerous to life and health (IDLH).

Suggestions provided in this section for exposure control and specific types of protective equipment are based on readily available information. Users should consult with the specific manufacturer to confirm the performance of their protective equipment. Specific situations may require consultation with industrial hygiene, safety, or engineering professionals.

9. Physical and Chemical Properties

Note: Unless otherwise stated, values are determined at 20°C (68°F) and 760 mm Hg (1 atm). Data represent typical values and are not intended to be specifications.

Appearance:	Clear and bright
Physical Form:	Liquid
Odor:	Petroleum
Odor Threshold:	No data
pH:	Not applicable
Vapor Pressure:	<1 mm Hg
Vapor Density (air=1):	>1
Boiling Point/Range:	No data
Melting/Freezing Point:	<-29.2°F / <-34°C
Pour Point:	<-29.2°F / <-34°C
Solubility in Water:	Insoluble
Partition Coefficient (n-octanol/water) (Kow):	No data
Specific Gravity:	0.87 @ 60°F (15.6°C)
Bulk Density:	7.3 lbs/gal
Viscosity:	7 - 12 cSt @ 100°C; 32 - 68 cSt @ 40°C
Evaporation Rate (nBuAc=1):	No data
Flash Point:	>320°F / >160°C
Test Method:	Pensky-Martens Closed Cup (PMCC), ASTM D93, EPA 1010
LEL (vol % in air):	No data
UEL (vol % in air):	No data
Autoignition Temperature:	No data

10. Stability and Reactivity

Stability: Stable under normal ambient and anticipated conditions of use.

Conditions to Avoid: Extended exposure to high temperatures can cause decomposition.

Materials to Avoid (Incompatible Materials): Avoid contact with strong oxidizing agents and strong reducing agents.

Hazardous Decomposition Products: Not anticipated under normal conditions of use.

Hazardous Polymerization: Not known to occur.

MATERIAL SAFETY DATA SHEET

POWERFLOW™ AW HVI HYDRAULIC OIL (CONTINUED)

814636 - Powerflow™ AW HVI Hydraulic Oil (All Grades)
Date of Issue: 14-Nov-2008

Page 5/7
Status: Final

11. Toxicological Information

Chronic Data:

Lubricant Base Oil (Petroleum)

Carcinogenicity: The petroleum base oils contained in this product have been highly refined by a variety of processes including severe hydrocracking/hydroprocessing to reduce aromatics and improve performance characteristics. All of the oils meet the IP-346 criteria of less than 3 percent PAH's and are not considered carcinogens by NTP, IARC, or OSHA.

Acute Data:

Component	Oral LD50	Dermal LD50	Inhalation LC50
Lubricant Base Oil (Petroleum)	>5 g/kg	>2 g/kg	No data

12. Ecological Information

Ecotoxicity: Experimental studies show that acute aquatic toxicity values are greater than 1000 mg/l. These values are consistent with the predicted aquatic toxicity of these substances based on their hydrocarbon compositions.

Mobility: Volatilization to air is not expected to be a significant fate process due to the low vapor pressure of this material. In water, base oils will float and spread over the surface at a rate dependent upon viscosity. There will be significant removal of hydrocarbons from the water by sediment adsorption. In soil and sediment, hydrocarbon components will show low mobility with adsorption to sediments being the predominant physical process. The main fate process is expected to be slow biodegradation of base oil components in soil and sediment.

Persistence and degradability: The hydrocarbons in this material are not readily biodegradable, but since they can be degraded by microorganisms, they are regarded as inherently biodegradable.

Bioaccumulation Potential: Log Kow values measured for the hydrocarbon components of this material range from 4 to over 6, and therefore regarded as having the potential to bioaccumulate. In practice, metabolic processes may reduce bioconcentration.

13. Disposal Considerations

The generator of a waste is always responsible for making proper hazardous waste determinations and needs to consider state and local requirements in addition to federal regulations.

This material, if discarded as produced, would not be a federally regulated RCRA "listed" hazardous waste and is not believed to exhibit characteristics of hazardous waste. See Sections 7 and 8 for information on handling, storage and personal protection and Section 9 for physical/chemical properties. It is possible that the material as produced contains constituents which are not required to be listed in the MSDS but could affect the hazardous waste determination. Additionally, use which results in chemical or physical change of this material could subject it to regulation as a hazardous waste.

This material under most intended uses would become "Used Oil" due to contamination by physical or chemical impurities. Whenever possible, Recycle Used Oil in accordance with applicable federal and state or local regulations. Container contents should be completely used and containers should be emptied prior to discard.

14. Transportation Information

U.S. Department of Transportation (DOT)

Shipping Description: *Not regulated*
Note: *If shipped by land in a packaging having a capacity of 3,500 gallons or more, the provisions of 49 CFR, Part 130 apply. (Contains oil)*

International Maritime Dangerous Goods (IMDG)

Shipping Description: *Not regulated*
Note: *U.S. DOT compliance requirements may apply. See 49 CFR 171.22, 23 & 25.*

International Civil Aviation Org. / International Air Transport Assoc. (ICAO/IATA)

UN/ID #: *Not regulated*

MATERIAL SAFETY DATA SHEET

POWERFLOW™ AW HVI HYDRAULIC OIL (CONTINUED)

814636 - Powerflow™ AW HVI Hydraulic Oil (All Grades)
Date of Issue: 14-Nov-2008

Page 6/7
Status: **Final**

14. Transportation Information

	LTD. QTY	Passenger Aircraft	Cargo Aircraft Only
Packaging Instruction #:	---	---	---
Max. Net Qty. Per Package:	---	---	---

15. Regulatory Information

CERCLA/SARA - Section 302 Extremely Hazardous Substances and TPQs (in pounds):

This material does not contain any chemicals subject to the reporting requirements of SARA 302 and 40 CFR 372.

CERCLA/SARA - Section 311/312 (Title III Hazard Categories)

Acute Health:	No
Chronic Health:	No
Fire Hazard:	No
Pressure Hazard:	No
Reactive Hazard:	No

CERCLA/SARA - Section 313 and 40 CFR 372:

This material contains the following chemicals subject to the reporting requirements of Section 313 of SARA Title III and 40 CFR 372:

Component	Concentration*	de minimis
Zinc Compound(s)	1	1.0%

EPA (CERCLA) Reportable Quantity (in pounds):

This material does not contain any chemicals with CERCLA Reportable Quantities.

California Proposition 65:

This material does not contain any chemicals which are known to the State of California to cause cancer, birth defects or other reproductive harm at concentrations that trigger the warning requirements of California Proposition 65.

Canadian Regulations:

This product has been classified in accordance with the hazard criteria of the Controlled Products Regulations (CPR) and the MSDS contains all the information required by the Regulations.

WHMIS Hazard Class
None

National Chemical Inventories:

All components are either listed on the US TSCA Inventory, or are not regulated under TSCA.
All components are either on the DSL, or are exempt from DSL listing requirements.

U.S. Export Control Classification Number: EAR99

16. Other Information

Date of Issue: 14-Nov-2008
Status: **Final**
Revised Sections or Basis for Revision: New MSDS
MSDS Number: 814636

Guide to Abbreviations:

ACGIH = American Conference of Governmental Industrial Hygienists; CASRN = Chemical Abstracts Service Registry Number; CEILING = Ceiling Limit (15 minutes); CERCLA = The Comprehensive Environmental Response, Compensation, and Liability Act; EPA = Environmental Protection Agency; IARC = International Agency for Research on Cancer; LEL = Lower Explosive Limit; NE = Not Established; NFPA = National Fire Protection Association; NTP = National Toxicology Program; OSHA = Occupational Safety and Health Administration; PEL = Permissible Exposure Limit (OSHA); SARA = Superfund Amendments and Reauthorization Act; STEL = Short Term Exposure Limit (15 minutes); TLV = Threshold Limit Value (ACGIH); TWA = Time Weighted Average (8 hours); UEL = Upper Explosive Limit; WHMIS = Worker Hazardous Materials Information System (Canada)

MATERIAL SAFETY DATA SHEET

POWERFLOW™ AW HVI HYDRAULIC OIL (CONTINUED)

814636 - Powerflow™ AW HVI Hydraulic Oil (All Grades)
Date of Issue: 14-Nov-2008

Page 717
Status: Final

Disclaimer of Expressed and implied Warranties:

The information presented in this Material Safety Data Sheet is based on data believed to be accurate as of the date this Material Safety Data Sheet was prepared. HOWEVER, NO WARRANTY OF MERCHANTABILITY, FITNESS FOR ANY PARTICULAR PURPOSE, OR ANY OTHER WARRANTY IS EXPRESSED OR IS TO BE IMPLIED REGARDING THE ACCURACY OR COMPLETENESS OF THE INFORMATION PROVIDED ABOVE, THE RESULTS TO BE OBTAINED FROM THE USE OF THIS INFORMATION OR THE PRODUCT, THE SAFETY OF THIS PRODUCT, OR THE HAZARDS RELATED TO ITS USE. No responsibility is assumed for any damage or injury resulting from abnormal use or from any failure to adhere to recommended practices. The information provided above, and the product, are furnished on the condition that the person receiving them shall make their own determination as to the suitability of the product for their particular purpose and on the condition that they assume the risk of their use. In addition, no authorization is given nor implied to practice any patented invention without a license.

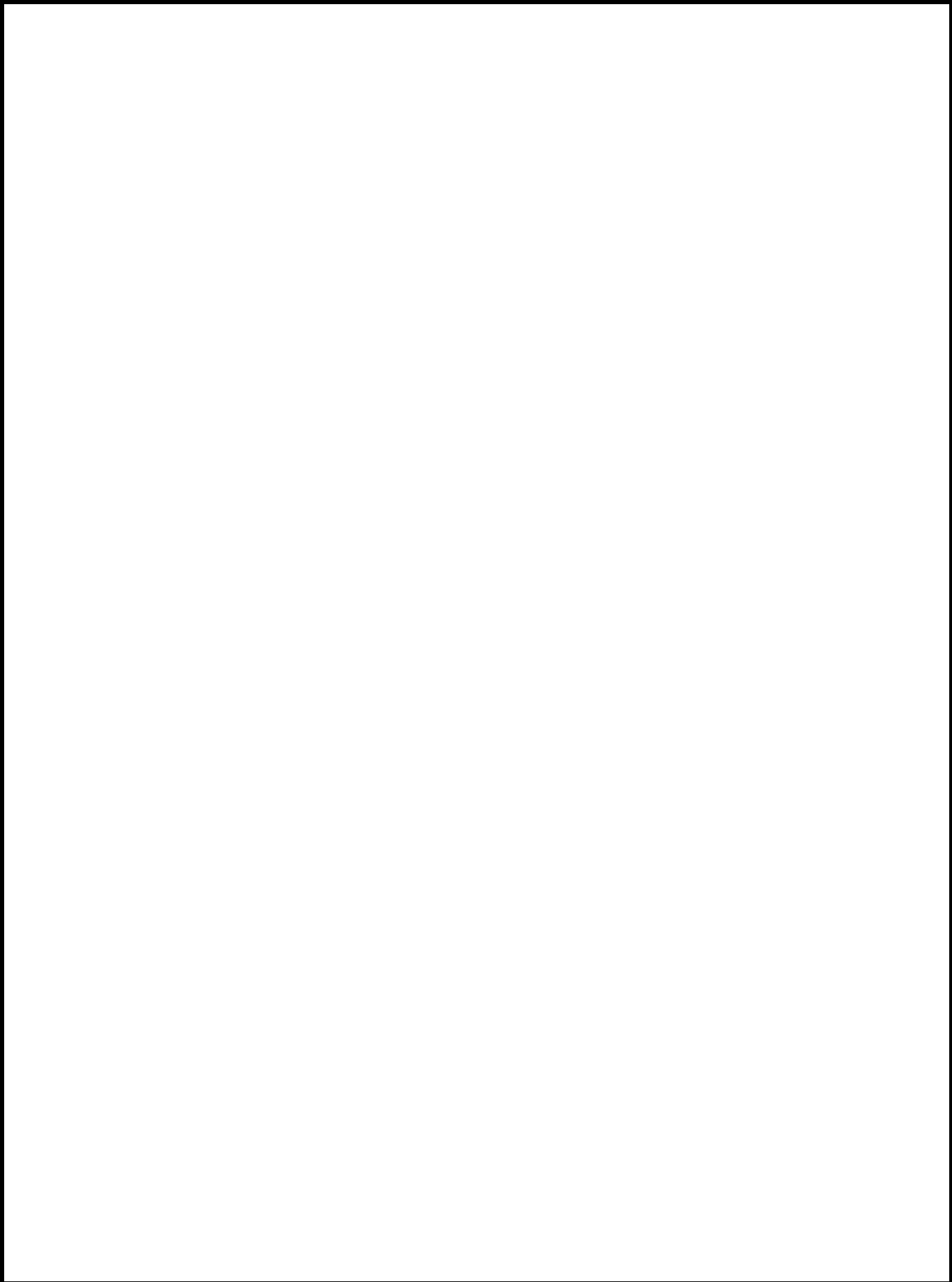

10 AXLE AND RELATED COMPONENTS

The following sections are reprinted from the Dexter Axle Operation and Maintenance Manual 2008.

SET UP AND ADJUSTMENT



Important Safety Notice

Appropriate service methods and repair procedures are essential for the safe, reliable operation of all running gear as well as the personal safety of the individual doing the work. This manual provides general directions for performing service and repair work with tested, effective techniques. Following these guidelines will help assure reliability.

There are numerous variations in procedures, techniques, tools, parts for servicing axles, as well as in the skill of the individual doing the work. This manual cannot possibly anticipate all such variations and provide advice or cautions as to each. Anyone who departs from the instructions provided in this manual must first establish that they neither compromise their personal safety nor the vehicle integrity by their choice of methods, tools, or parts.

Refer to your vehicle manufacturer's owners manual for additional procedures, techniques, and warnings prior to performing any maintenance or repairs.

CAUTION

This is the safety alert symbol. It is used to alert you to potential injury hazards. Obey all safety messages that follow this symbol to avoid possible injury or death.

Getting Started - Setup and Adjustment

For proper performance, all new axles should have the following checked at the specified intervals:

- **Wheel Nut Torque:** at 10, 25, and 50 miles
- **Brake Adjustment:** at 200 and 3,000 miles
- **Tire pressure:** to manufacturer's requirements
- **Brake synchronization:** set brake controller per controller manufacturer's directions

SET UP AND ADJUSTMENT (CONTINUED)

General Maintenance - Electric Brakes

Brake Adjustment

Most Dexter 12 $\frac{1}{4}$ " electric brakes have a self adjusting feature. If manual adjusting is required, use the following procedure:

Brakes should be adjusted (1) after the first 200 miles of operation when the brake shoes and drums have "seated," (2) at 3,000 mile intervals, (3) or as use and performance requires. The brakes should be adjusted in the following manner:

1. Jack up trailer and secure on adequate capacity jack stands. Follow trailer manufacturer's recommendations for lifting and supporting the unit. Make sure the wheel and drum rotates freely.



CAUTION

Do not lift or support the trailer on any part of the axle or suspension system. Never go under any trailer unless it is properly supported on jack stands which have been rated for the load. Improperly supported vehicles can fall unexpectedly and cause serious injury.

2. Remove the adjusting hole cover from the adjusting slot on the bottom of the brake backing plate.
3. With a screwdriver or standard adjusting tool, rotate the star wheel of the adjuster assembly to expand the brake shoes. Adjust the brake shoes out until the pressure of the linings against the drum makes the wheel very difficult to turn.
Note: For drop spindle axles, a modified adjusting tool may be necessary.
4. Then rotate the star wheel in the opposite direction until the wheel turns freely with a slight lining drag.
5. Replace the adjusting hole cover and lower the wheel to the ground.
6. Repeat the above procedure on all brakes. For best results, the brakes should all be set at the same clearance.

SET UP AND ADJUSTMENT (CONTINUED)

General Maintenance - Hydraulic Brakes

Drum Brake Adjustment - Manual

Most Dexter 12¼" hydraulic brakes have a self adjusting feature. If manual adjusting is required, use the following procedure:

Brakes should be adjusted (1) after the first 200 miles of operation when the brake shoes and drums have "seated," (2) at 3,000 mile intervals, (3) or as use and performance requires. The brakes should be adjusted in the following manner:

1. Jack up trailer and secure on adequate capacity jack stands. Follow trailer manufacturer's recommendations for lifting and supporting the unit. Make sure the wheel and drum rotates freely.



CAUTION

Do not lift or support the trailer on any part of the axle or suspension system. Never go under any trailer unless it is properly supported on jack stands which have been rated for the load. Improperly supported vehicles can fall unexpectedly and cause serious injury or death.

2. Remove the adjusting hole cover from the adjusting slot on the bottom of the brake backing plate.
3. With a screwdriver or standard adjusting tool, rotate the star wheel of the adjuster assembly to expand the brake shoes. Adjust the brake shoes out until the pressure of the linings against the drum makes the wheel very difficult to turn.
Note: For drop spindle axles, a modified adjusting tool may be necessary.
4. Then rotate the star wheel in the opposite direction until the wheel turns freely with a slight lining drag.
5. Replace the adjusting hole cover and lower the wheel to the ground.
6. Repeat the above procedure on all brakes. For best results, the brakes should all be set at the same clearance.



SET UP AND ADJUSTMENT (CONTINUED)

Synchronizing Your Trailer Brakes

To insure safe brake performance and synchronization, read the brake controller manufacturer's instructions completely before attempting any synchronization procedure.

CAUTION

Before road testing, make sure the area is clear of vehicular and pedestrian traffic. Failure to brake safely could result in an accident and personal injury to yourself and/or others.

Make several hard stops from 20 m.p.h. on a dry paved road free of sand and gravel. If the trailer brakes lock and slide, decrease the gain setting on the controller. If they do not slide, slightly increase the gain setting. Adjust the controller just to the point of impending brake lockup and wheel skid.

Note: Not all trailer brakes are capable of wheel lockup. Loading conditions, brake type, wheel and tire size can all affect whether a brake can lock. It is not generally considered desirable to lock up the brakes and slide the tires. This can cause unwanted flat spotting of the tires and could also result in a loss of control.

If the controller is applying the trailer brakes before the tow vehicle brakes, then the controller adjustments should be made so the trailer brakes come on in synchronization with the tow vehicle brakes. For proper braking performance, it is recommended that the controller be adjusted to allow the trailer brakes to come on just slightly ahead of the tow vehicle brakes. When proper synchronization is achieved there will be no sensation of the trailer "jerking" or "pushing" the tow vehicle during braking.

SET UP AND ADJUSTMENT (CONTINUED)

CAUTION

Do not attempt to repair or modify a damaged wheel. Even minor modifications can cause a dangerous failure of the wheel and result in personal injury or death.

Torque Requirements

In June of 2004, Dexter Axle ceased production of trailer wheels. If your vehicle is equipped with Dexter steel wheels manufactured before that date, the following wheel torque information will be applicable.

If your trailer is equipped with wheels produced by other manufacturers, you must consult with the vehicle manufacturer to determine the appropriate torque level for your wheels. However, you must not exceed the limits of the wheel mounting studs on the axles.

It is extremely important to apply and maintain proper wheel mounting torque on your trailer axle. Torque is a measure of the amount of tightening applied to a fastener (nut or bolt) and is expressed as length force. For example, a force of 90 pounds applied at the end of a wrench one foot long will yield **90 Ft. Lbs.** of torque. Torque wrenches are the best method to assure the proper amount of torque is being applied to a fastener.

CAUTION

Wheel nuts or bolts must be tightened and maintained at the proper torque levels to prevent loose wheels, broken studs, and possible dangerous separation of wheels from your axle, which can lead to an accident, personal injuries or death.

Be sure to use only the fasteners matched to the cone angle of your wheel (usually 60° or 90°). The proper procedure for attaching your wheels is as follows:

1. Start all bolts or nuts by hand to prevent cross threading.

SET UP AND ADJUSTMENT (CONTINUED)

2. Tighten bolts or nuts in the sequence shown for Wheel Torque Requirements.
3. The tightening of the fasteners should be done in stages. Following the recommended sequence, tighten fasteners per wheel torque requirements diagram.
4. Wheel nuts/bolts should be torqued before first road use and after each wheel removal. Check and re-torque after the first 10 miles, 25 miles, and again at 50 miles. Check periodically thereafter.

Wheel Torque Requirements

(For Dexter Steel Wheels Prior to June of 2004)

Torque Sequence

Wheel Size	1st Stage	2nd Stage	3rd Stage
12"	20-25	35-40	50-75
13"	20-25	35-40	50-75
14"	20-25	50-60	90-120
15"	20-25	50-60	90-120
16"	20-25	50-60	90-120
16.5" x 6.75"	20-25	50-60	90-120
16.5" x 9.75"	55-60	120-125	175-225
14.5" Demount	Tighten sequentially to		85-95
17.5" Hub Pilot Clamp ring & Cone Nuts	50-60	100-120	190-210
17.5" Hub Pilot 5/8" Flange Nuts	50-60	90-200	275-325

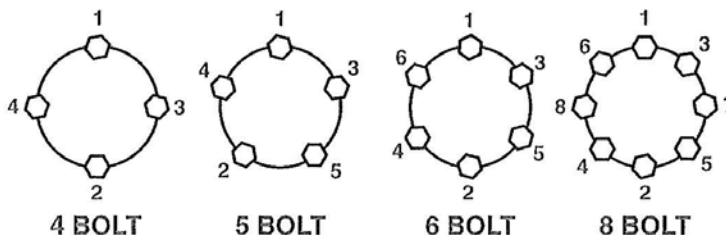

SET UP AND ADJUSTMENT (CONTINUED)***Maximum Wheel Fastener Torque***

The wheel mounting studs used on Dexter axles conform to the SAE standards for grade 8. The maximum torque level that can be safely applied to these studs is listed in the following chart:

Stud Size	Maximum Torque
1/2"-20 UNF, class 2A	120 Ft. Lbs.
9/16"-18 UNF, class 2A	170 Ft. Lbs.
5/8"-18 UNF, class 2A	325 Ft. Lbs.

**CAUTION**

Exceeding the above listed torque limits can damage studs and/or nuts and lead to eventual fractures and dangerous wheel separation.

HOW TO USE YOUR BRAKES PROPERLY

How to Use Your Electric Brakes Properly

Your trailer brakes are designed to work in synchronization with your tow vehicle brakes. Never use your tow vehicle or trailer brakes alone to stop the combined load.

Your brake controller must be set up according to the manufacturer's recommendations to ensure proper synchronization between the tow vehicle and the trailer. Additionally, you may have to make small adjustments occasionally to accommodate changing loads and driving conditions.

Proper synchronization of tow vehicle to trailer braking can only be accomplished by road testing. Brake lockup, grabbiness, or harshness is quite often due to the lack of synchronization between the tow vehicle and the trailer being towed, too high of a threshold voltage (over 2 volts), or under adjusted brakes.

Before any synchronization adjustments are made, your trailer brakes should be burnished-in by applying the brakes 20-30 times with approximately a 20 m.p.h. decrease in speed, e.g. 40 m.p.h. to 20 m.p.h. Allow ample time for brakes to cool between application. This allows the brake shoes and magnets to slightly "wear-in" to the drum surfaces.

Trailer Wire Size Chart

Number of Brakes	Hitch-to-Axle Distance in Feet	Recommended Minimum Hookup Wire Size (Copper)
2		12 AWG
4	Under 30	12 AWG
4	30-50	10 AWG
6	Under 30	10 AWG
6	30-50	8 AWG

MAINTENANCE

Maintenance Schedule

Maintenance Schedule

Item	Function Required	Weekly	3 Months or 3,000 Miles	6 Months or 6,000 Miles	12 Months or 12,000 Miles
Brakes	Test that they are operational.	At Every Use			
Brake Adjustment	Adjust to proper operating clearance.		●		
Brake Magnets	Inspect for wear and current draw.			●	
Brake Linings	Inspect for wear or contamination.				●
Brake Controller	Check for correct amperage and modulation.			●	
Brake Cylinders	Check for leaks, sticking.				●
Brake Lines	Inspect for cracks, leaks, kinks.				●
Trailer Brake Wiring	Inspect wiring for bare spots, fray, etc.				●
Breakaway System	Check battery charge and switch operation.	At Every Use			
Hub/Drum	Inspect for abnormal wear or scoring.				●
Wheel Bearings and Cups	Inspect for corrosion or wear. Clean and repack.				●
Seals	Inspect for leakage. Replace if removed.				●
Springs	Inspect for wear, loss of arch.				●
Suspension Parts	Inspect for bending, loose fasteners and wear.			●	
Hangers	Inspect welds.				●
Wheel Nuts and Bolts	Tighten to specified torque values.		●		
Wheels	Inspect for cracks, dents, or distortion.			●	
Tire Inflation Pressure	Inflate tires to mfg's specifications.	●			
Tire Condition	Inspect for cuts, wear, bulging, etc.		●		

MAINTENANCE (CONTINUED)

Magnets

Your electric brakes are equipped with high quality electromagnets that are designed to provide the proper input force and friction characteristics. Your magnets should be inspected and replaced if worn unevenly or abnormally. As indicated below, a straightedge should be used to check magnet condition. For best results, the magnet should be flat.

Even if wear is normal as indicated by your straightedge, the magnets should be replaced if any part of the magnet coil has become visible through the friction material facing of the magnet. It is also recommended that the drum armature surface be refaced when replacing magnets (see section on Brake Drum Inspection). Magnets should also be replaced in pairs - both sides of an axle. Use only genuine Dexter replacement parts when replacing your magnets.

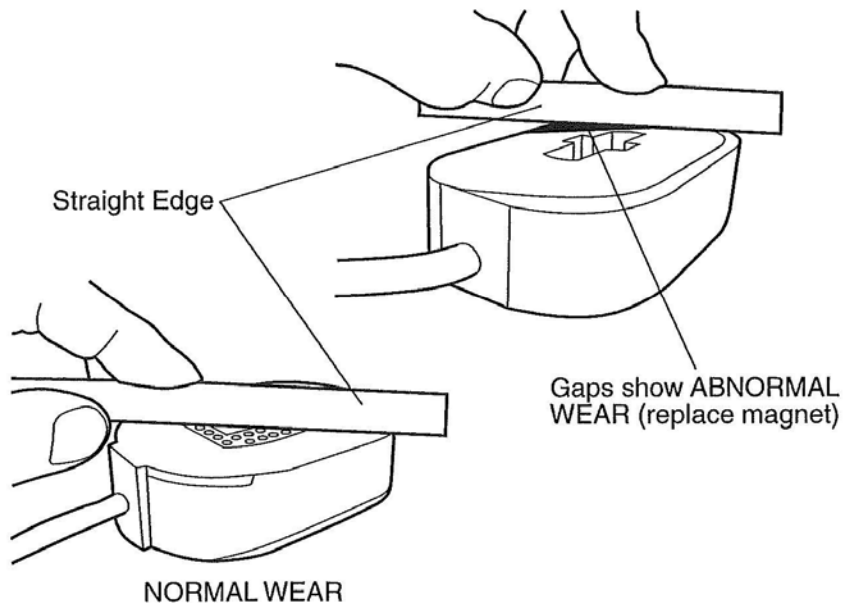

MAINTENANCE (CONTINUED)***Brake Cleaning and Inspection***

Your trailer brakes must be inspected and serviced immediately if a loss of performance is indicated. With normal use, servicing at one year intervals is usually adequate. With increased usage, this work should be done more frequently as required. Magnets and shoes must be changed when they become excessively worn or scored, a condition which can reduce vehicle braking.

Clean the backing plate, magnet arm, magnet, and brake shoes. Make certain that all the parts removed are replaced in the same brake and drum assembly. Inspect for any loose or worn parts, stretched or deformed springs and replace as necessary.

**CAUTION****POTENTIAL ASBESTOS DUST HAZARD!**

Some older brake linings may contain asbestos dust, which has been linked to serious or fatal illnesses.

Certain precautions need to be taken when servicing brakes:

- 1. Avoid creating or breathing dust.**
- 2. Avoid machining, filing or grinding the brake linings.**
- 3. Do not use compressed air or dry brushing for cleaning (dust can be removed with a damp brush).**

Brake Lubrication

Before reassembling, apply a light film of grease or anti-seize compound on the brake anchor pin, the actuating arm bushing and pin, and the areas on the backing plate that are in contact with the brake shoes and magnet lever arm. Apply a light film of grease on the actuating block mounted on the actuating arm.

CAUTION

Do not get grease or oil on the brake linings, drums or magnets.

MAINTENANCE (CONTINUED)**Shoes and Linings**

A simple visual inspection of your brake linings will tell if they are usable. Replacement is necessary if the lining is worn to $\frac{1}{16}$ " or less. Shoes contaminated with grease or oil, or abnormally scored or gouged should also be replaced. Hairline heat cracks are normal in bonded linings and should not be cause for concern. When replacement is necessary, it is important to replace both shoes on each brake and both brakes of the same axle. This will help retain the "balance" of your brakes.

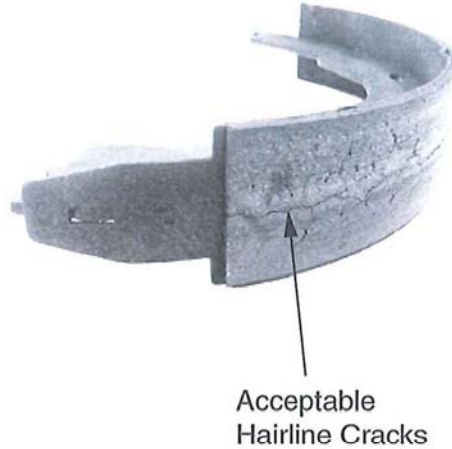

⚠ CAUTION

POTENTIAL ASBESTOS DUST HAZARD!

Some older brake linings may contain asbestos dust, which has been linked to serious or fatal illnesses. Certain precautions need to be taken when servicing brakes:

- 1. Avoid creating or breathing dust.**
- 2. Avoid machining, filing or grinding the brake linings.**
- 3. Do not use compressed air or dry brushing for cleaning (dust can be removed with a damp brush).**

After replacement of brake shoes and linings, the brakes must be re-burnished to seat in the new components. This should be done by applying the brakes 20 to 30 times from an initial speed of 40 m.p.h., slowing the vehicle to 20 m.p.h. Allow ample time for brakes to cool between applications. This procedure allows the brake shoes to seat in to the drum surface.

MAINTENANCE (CONTINUED)

Hubs/Drums/Bearings

Hubs/Drums/Bearings

Dexter Axle offers several types of bearing arrangements and lubrications methods.

- Dexter's standard wheel bearing configuration consists of opposed tapered roller bearing cones and cups, fitted inside of a precision machined cast hub. This method of using tapered roller bearings requires that a minimal amount of axial end play be provided at assembly. This end play is essential to the longevity of the bearings service life. This design is typically lubricated with grease, packed into the bearings. Oil lubrication is another method which is available in some of the larger axle capacities.
- E-Z Lube® is another option chosen by some trailer manufacturers. If your axle is equipped with the Dexter E-Z Lube® feature, the bearings can be periodically lubricated without removing the hubs from the axle. This feature consists of axle spindles that have been specially drilled and assembled with grease fittings in their ends. When grease is pumped into the fitting, it is channeled to the inner bearing and then flows back to the outer bearing and eventually back out the grease cap hole.
- Nev-R-Lube™ option is the latest innovation from Dexter. Nev-R-Lube™ bearings are comprised of opposed tapered roller bearing cones sealed inside of a precision ground, one piece double cup arrangement. These bearings are designed with a small amount of axial end play. This end play is essential to the longevity of the bearings service life. They are lubricated, assembled and sealed at the factory. No further lubrication is ever needed.

Before attempting any disassembly of your Dexter axle, make sure you read and follow the instructions for the appropriate axle type.

Hub Removal - Standard Bearings

Whenever the hub equipment on your axle must be removed for inspection or maintenance the following procedure should be utilized.

MAINTENANCE (CONTINUED)

1. Elevate and support the trailer unit per manufacturers' instructions.

CAUTION

You must follow the maintenance procedures to prevent damage to important structural components. Damage to certain structural components such as wheel bearings can cause the wheel end to come off of the axle. Loss of a wheel end while the trailer is moving can cause you to lose control and lead to an accident, which can result in serious injury or death.

2. Remove the wheel.
3. Remove the grease cap by carefully prying progressively around the flange of the cap. If the hub is an oil lube type, then the cap can be removed by unscrewing it counterclockwise while holding the hub stationary.
4. Remove the cotter pin from the spindle nut.

For E-Z Lube® axles produced after February of 2002, a new type of retainer is used. Gently pry off retainer from the nut and set aside.
5. Unscrew the spindle nut (counterclockwise) and remove the spindle washer.
6. Remove the hub from the spindle, being careful not to allow the outer bearing cone to fall out. The inner bearing cone will be retained by the seal.
7. For 7,200 lb. and 8,000 lb. axles, a hub puller may be necessary to assist in drum removal.

Brake Drum Inspection

There are two areas of the brake drum that are subject to wear and require periodic inspection. These two areas are the drum surface where the brake shoes make contact during stopping and the armature surface where the magnet contacts (only in electric brakes).

MAINTENANCE (CONTINUED)

The drum surface should be inspected for excessive wear or heavy scoring. If worn more than .020" oversized, or the drum has worn out of round by more than .015", then the drum surface should be re-machined. If scoring or other wear is greater than .090" on the diameter, the drum must be replaced. When turning the drum surface, the maximum rebores diameter is as follows:

- 7" Brake Drum-7.090" diameter
- 10" Brake Drum-10.090" diameter
- 12" Brake Drum-12.090" diameter
- 12¼" Brake Drum-12.340" diameter
- 6K and 8K Rotor-1.03" minimum thickness
- 3.5K Rotor-.85" minimum thickness

The machined inner surface of the brake drum that contacts the brake magnet is called the armature surface. If the armature surface is scored or worn unevenly, it should be refaced to a 120 micro inch finish by removing not more than .030" of material. To insure proper contact between the armature face and the magnet face, the magnets should be replaced whenever the armature surface is refaced and the armature surface should be refaced whenever the magnets are replaced.

Note: It is important to protect the wheel bearing bores from metallic chips and contamination which result from drum turning or armature refacing operations. Make certain that the wheel bearing cavities are clean and free of contamination before reinstalling bearing and seals. The presence of these contaminants will cause premature wheel bearing failure.

Bearing Inspection

Wash all grease and oil from the bearing cone using a suitable solvent. Dry the bearing with a clean, lint-free cloth and inspect each roller completely.

CAUTION

**Never spin the bearing with compressed air.
THIS CAN DAMAGE THE BEARING.**

MAINTENANCE (CONTINUED)

If any pitting, spalling, or corrosion is present, then the bearing must be replaced. The bearing cup inside the hub must be inspected.

IMPORTANT: Bearings must always be replaced in sets of a cone and a cup.

CAUTION

Be sure to wear safety glasses when removing or installing force fitted parts. Failure to comply may result in serious eye injury.

When replacing the bearing cup proceed as follows:

1. Place the hub on a flat work surface with the cup to be replaced on the bottom side.
2. Using a brass drift punch, carefully tap around the small diameter end of the cup to drive out.
3. After cleaning the hub bore area, replace the cup by tapping in with the brass drift punch. Be sure the cup is seated all the way up against the retaining shoulder in the hub.

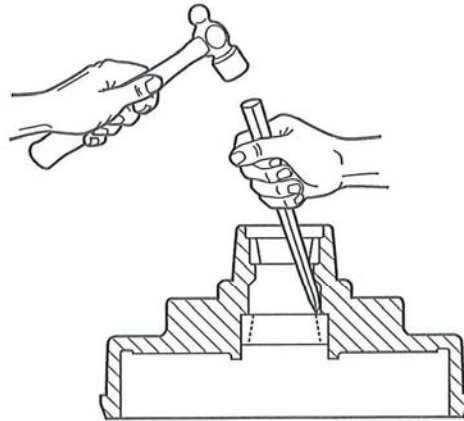

Replace only with bearings as specified in the Bearing Replacement Chart.

MAINTENANCE (CONTINUED)***Bearing Lubrication - Grease*****CAUTION**

Do not mix Lithium, calcium, sodium or barium complex greases due to possible compatibility problems. When changing from one type of grease to another, it is necessary to insure all the old grease has been removed.

Along with bearing adjustment, proper lubrication is essential to the proper function and reliability of your trailer axle. Bearings should be lubricated every 12 months or 12,000 miles. The method to repack bearing cones is as follows:

1. Place a quantity of grease into the palm of your hand.
2. Press a section of the widest end of the bearing into the outer edge of the grease pile closest to the thumb forcing grease into the interior of the bearing.
3. Repeat this while rotating the bearing from roller to roller.
4. Continue this process until you have the entire bearing completely filled with grease.
5. Before reinstalling, apply a light coat of grease on the bearing cup.

***Bearing Lubrication - Oil***

If your axles are equipped with oil lubricated hubs, periodically check and refill the hub as necessary with a high quality hypoid gear oil to the level indicated on the clear plastic oil cap. The oil can be filled from either the oil fill hole, if present, in the hub or through the rubber plug hole in the cap itself.

MAINTENANCE (CONTINUED)***Recommended Wheel Bearing
Lubrication Specifications*****Grease**

Thickener Type	Lithium Complex
Dropping Point	215°C (419°F) Minimum
Consistency	NLGI No. 2
Additives	EP, Corrosion & Oxidation Inhibitors
Viscosity Index	80 Minimum

Approved Grease Sources

ConocoPhillips/ 76 Lubricants/Kendall	Multiplex RED #2 L427 Super Blu Grease
Citgo	Lithoplex MP #2 Lithoplex CM #2 Mystik JT-6 Hi-Temp Grease #2
Exxon/Mobil Company	Ronex, MP Mobilith AW 2 Mobil I Synthetic Grease
Oil Center Research of Oklahoma	Liquid-O-Ring No, 167L
Pennzoil-Quaker State Company	Synthetic Red Grease
Shell	ALBIDA EP 2 ALBIDA Grease SLC 220 Rotella Heavy Duty Lithium Complex #2
Royal Mfg. Company	Royal 98 Lithium Complex EP #2
Chevron Texaco	Chevron Ulti-Plex Grease EP #2 Texaco Starplex Moly MPGM #2
Valvoline	Valvoline Multi-Purpose GM Valvoline Durablend
Great Plains Lubricants	Lithium Complex EP #2
Chem Arrow	Arrow 2282

Hubs/Drums/Bearings

MAINTENANCE (CONTINUED)**Oil**

SAE 90, SAE 80W-90, SAE 75W-90

Approved Oil Sources

Ashland Oil	Valvoline Dura Blend Valvoline Power Lube
CITGO Petroleum Co.	CITGO Premium Gear Oil MP Mystik JT-7 Mystik Power Lube
Exxon Company USA	Gear Oil GX 80W-90
Industrial Oils Unlimited	Super MP Gear Oil 80W-90
Kendall Refining Co.	Kendall NS-MP Hypoid Gear Lube
Lubriplate Division/ Fiske Brothers Refining	Lubriplate APG 90
Mobil Oil Corporation	Mobilube SHC Mobil 1 Synthetic Gear Lube
Phillips 66 Petroleum	Superior Multi-Purpose Gear Oil Philguard Gear Oil Philsyn Gear Oil
Pennzoil Products Co.	Gear Plus 80W-90 GL-5 Gear Plus Super 75W-90 Gear Plus Super EW 80W-90 Multi-Purpose 4092 Gear Lube
Oil Center Research	Liquid-O-Ring 750 GX
Sun Refining and Marketing Company	Sonoco Ultra Sonoco Dura Gear
Shell Oil Company	Spirax A Spirax G Spirax HD Spirax S
Texaco Oil Company	Multigear EP Multigear SS
Troco Division/ Royal Manufacturing	Multigear Select Gear Oil
Union Oil Company	Unocal MP Gear Lube 76 Triton Syn Lube EP

Hubs/Drums/Bearings

MAINTENANCE (CONTINUED)

Note: The convenient lubrication provisions of the E-Z Lube® and the oil lubrication must not replace periodic inspection of the bearings.

Seal Inspection and Replacement

Whenever the hub is removed, inspect the seal to assure that it is not nicked or torn and is still capable of properly sealing the bearing cavity. If there is any question of condition, replace the seal. Use only the seals specified in the Seal Replacement Chart.

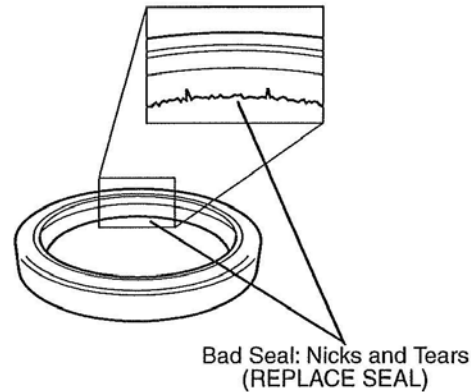

To replace the seal:

1. Pry the seal out of the hub with a screwdriver. Never drive the seal out with the inner bearing as you may damage the bearing.
2. Apply a PERMATEX sealant to the outside of the new seal.

Note: Permatex sealant should not be used on rubber encased seals.

3. Tap the new seal into place using a clean wood block.

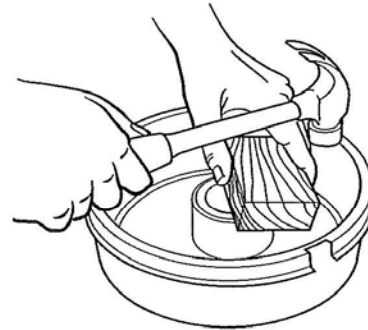

Bearing Adjustment and Hub Replacement

If the hub has been removed or bearing adjustment is required, the following adjustment procedure must be followed:

1. After placing the hub, bearings, washers, and spindle nut back on the axle spindle in reverse order as detailed in the previous section on hub removal, rotate the hub assembly slowly while tightening the spindle nut to approximately **50 Ft. Lbs.** (12" wrench or pliers with full hand force.)
2. Then loosen the spindle nut to remove the torque. Do not rotate the hub.

MAINTENANCE (CONTINUED)

3. Finger tighten the spindle nut until just snug.
4. Back the spindle nut out slightly until the first castellation lines up with the cotter key hole and insert the cotter pin.
5. Bend over the cotter pin legs to secure the nut.
6. Nut should be free to move with only restraint being the cotter pin.

For E-Z Lube® axles using the new nut retainer:

1. After placing the hub, bearings, washers, and spindle nut back on the axle spindle in reverse order as detailed in the previous section on hub removal, rotate the hub assembly slowly while tightening the spindle nut to approximately **50 Ft. Lbs.** (12" wrench or pliers with full hand force.)
2. Then loosen the spindle nut to remove the torque. Do not rotate the hub.
3. Finger tighten the nut until just snug, align the retainer to the machined flat on the spindle and press the retainer onto the nut. The retainer should snap into place. Once in place, the retainer/nut assembly should be free to move slightly.
4. If the nut is too tight, remove the retainer and back the nut off approximately one twelfth of a turn and reinstall the retainer. The nut should now be free to move slightly.
5. Reinstall grease cap.

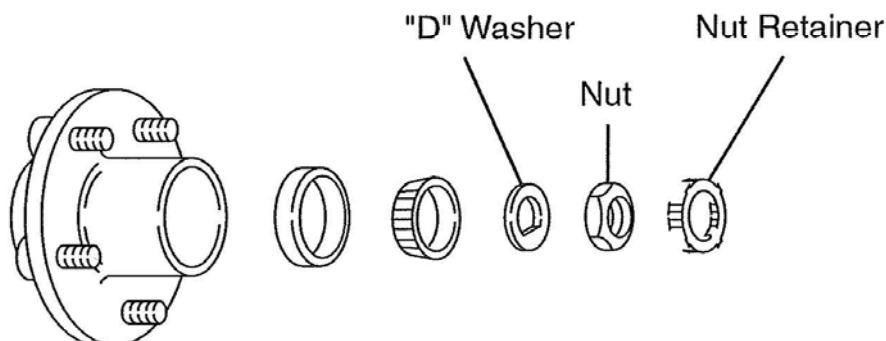
Typical E-Z Lube® After Spring 2002

MAINTENANCE (CONTINUED)

E-Z Lube® Lubrication

The procedure is as follows:

1. Remove the rubber plug from the end of the grease cap.
2. Place a standard grease gun onto the grease fitting located in the end of the spindle. Make sure the grease gun nozzle is fully engaged on the fitting.
3. Pump grease into the fitting. The old displaced grease will begin to flow back out the cap around the grease gun nozzle.
4. When the new clean grease is observed, remove the grease gun, wipe off any excess, and replace the rubber plug in the cap.
5. Rotate hub or drum while adding grease.

Note: The E-Z Lube® feature is designed to allow immersion in water. Axles not equipped with E-Z Lube® are not designed for immersion and bearings should be repacked after each immersion. If hubs are removed from an axle with the E-Z Lube® feature, it is imperative that the seals be replaced BEFORE bearing lubrication. Otherwise, the chance of grease getting on brake linings is greatly increased.

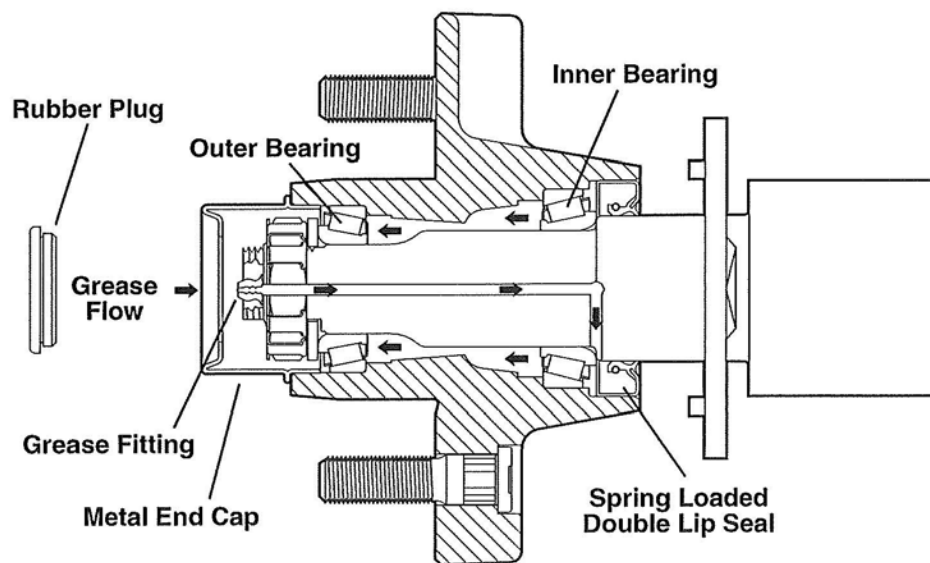

Hubs/Drums/Bearings

MAINTENANCE (CONTINUED)***Bearing Replacement and Drum Installation***

1. Once the drum and bearing assembly is removed from the axle, remove "internal" snap ring from the bearing bore that retains bearing.
2. Using an arbor press and mandrel, press the bearing out of the drum. Bearing will exit on the wheel side of the drum.
3. When replacing a Nev-R-Lube™ bearing pack, the bore in the hub should be cleaned and inspected for visual damage (replace as necessary).

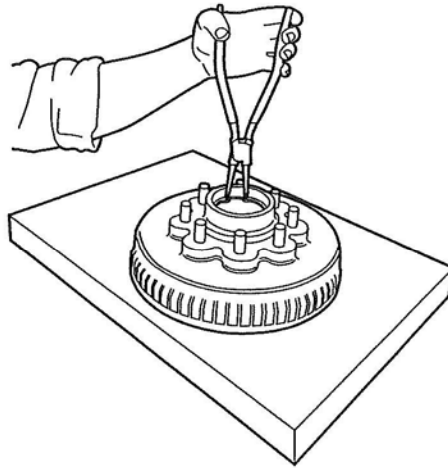

4. Install the new bearing using an arbor press fitted with a hollow or stepped punch face to press only on the outer housing of the bearing. Failure to follow procedure will damage the bearing and/or seals during installation. Press bearing until it seats against the backup shoulder machined into the hub.

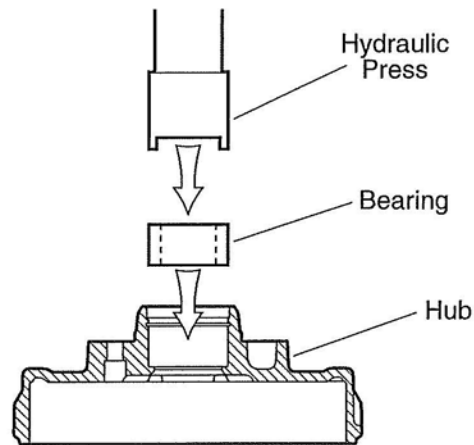

5. Install "internal" snap ring into hub.
6. Clean and inspect spindle shaft. Apply a light coating of anti-seize lubricant to the spindle shaft prior to assembling drum.
7. Install drum assembly onto spindle (Do NOT FORCE).
8. Install steel washer onto spindle end.
9. Start self-locking nut onto spindle thread by hand. Complete installation using a 1½" or 1⅞" socket and torque wrench.

MAINTENANCE (CONTINUED)

Nut should be torqued to **145-155 Ft. Lbs.** (this torque will set the internal bearing adjustment, no other adjustments are to be made).

10. Install "torque instruction" washer onto end of spindle.
11. Install "external" snap ring onto end of spindle to retain washer.
12. Inspect assembly for excessive end play, noise, and rotation restriction prior to mounting final wheel end hardware.

Hubs/Drums/Bearings

MAINTENANCE (CONTINUED)

Tires

Before mounting tires onto the wheels, make certain that the rim size and contour is approved for the tire as shown in the Tire and Rim Association Yearbook or the tire manufacturers catalog. Also make sure the tire will carry the rated load. If the load is not equal on all tires due to trailer weight distribution, use the tire rated for the heaviest wheel position.

Note: The capacity rating molded into the sidewall of the tire is not always the proper rating for the tire if used in a trailer application. Use the following guidelines:

1. LT and ST tires. Use the capacity rating molded into the tire.
2. Passenger Car Tires. Use the capacity rating molded into the tire sidewall **divided by 1.10** for trailer use.





Use tire mounting procedures as outlined by the Rubber Manufacturer's Association or the tire manufacturers.

Tire inflation pressure is the most important factor in tire life. Inflation pressure should be as recommended by the manufacturer for the load. Pressure should be checked cold before operation. Do not bleed air from tires when they are hot. Check inflation pressure weekly during use to insure the maximum tire life and tread wear. The following tire wear diagnostic chart will help you pinpoint the causes and solutions of tire wear problems.

CAUTION

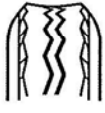
Tire wear should be checked frequently because once a wear pattern becomes firmly established in a tire it is difficult to stop, even if the underlying cause is corrected.

MAINTENANCE (CONTINUED)***Tire Wear Diagnostic Chart***

Wear Pattern	Cause	Action	
	Center Wear	Over Inflation	Adjust pressure to particular load per tire catalog
	Edge Wear	Under Inflation	Adjust pressure to particular load per tire catalog
	Side Wear	Loss of camber or overloading	Make sure load doesn't exceed axle rating. Align at alignment shop
	Toe Wear	Incorrect toe-in	Align at alignment shop
	Cupping	Out-of-balance	Check bearing adjustment and balance tires
	Flat Spots	Wheel lockup & tire skidding	Avoid sudden stops when possible and adjust brakes

MAINTENANCE (CONTINUED)***How to Measure Voltage***

System voltage is measured at the magnets by connecting the voltmeter to the two magnet lead wires at any brake. This may be accomplished by using a pin probe inserted through the insulation of the wires. The engine of the towing vehicle should be running when checking the voltage so that a low battery will not affect the readings.

Voltage in the system should begin at 0 volts and, as the controller bar is slowly actuated, should gradually increase to about 12 volts. If the controller does not produce this voltage control, consult your controller manual.

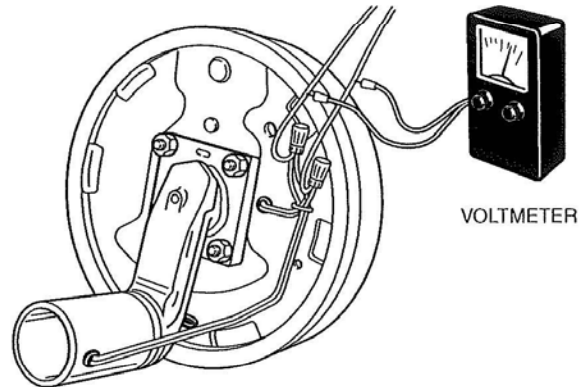

The threshold voltage of a controller is the voltage applied to the brakes when the controller first turns on. Lower threshold voltage will provide for smoother braking. If the threshold voltage is too high, the brakes may feel grabby and harsh.

How to Measure Amperage

System amperage is the current flowing in the system when all the magnets are energized. The amperage will vary in proportion to the voltage. The engine of the tow vehicle should be running with the trailer connected when checking the trailer braking system.

One place to measure system amperage is at the BLUE wire of the controller, which is the output to the brakes. The BLUE wire must be disconnected and the ammeter put in series into the line. System amperage draw should be as noted in the following table. Make sure your ammeter has sufficient capacity and note polarity to prevent damaging your ammeter.

MAINTENANCE (CONTINUED)***Magnet Amperes Chart***

Brake Size	Amps/ Magnet	Two Brakes	Four Brakes	Six Brakes	Magnet Ohms
7" x 1¼"	2.5	5.0	10.0	15.0	3.9
10" x 1½"	3.0	6.0	12.0	18.0	3.2
10" x 2¼"	3.0	6.0	12.0	18.0	3.2
12" x 2"	3.0	6.0	12.0	18.0	3.2
12¼" x 2½"	3.0	6.0	12.0	18.0	3.2
12¼" x 3⅜"	3.0	6.0	12.0	18.0	3.2

If a resistor is used in the brake system, it must be set at zero or bypassed completely to obtain the maximum amperage reading. Individual amperage draw can be measured by inserting the ammeter in the line at the magnet you want to check. Disconnect one of the magnet lead wire connectors and attach the ammeter between the two wires. Make sure that the wires are properly reconnected and sealed after testing is completed.

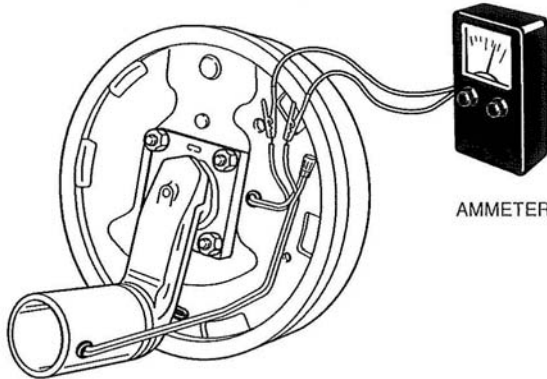

The most common electrical problem is low or no voltage and amperage at the brakes. Common causes of this condition are:

1. Poor electrical connections
2. Open circuits
3. Insufficient wire size
4. Broken wires
5. Blown fuses (fusing of brakes is not recommended)
6. Improperly functioning controllers or resistors

Another common electrical problem is shorted or partially shorted circuits (indicated by abnormally high system amperage). Possible causes are:

1. Shorted magnet coils
2. Defective controllers
3. Bare wires contacting a grounded object



MAINTENANCE (CONTINUED)

Finding the cause of a short circuit in the system is done by isolating one section at a time. If the high amperage reading drops to zero by unplugging the trailer, then the short is in the trailer. If the amperage reading remains high with all the brake magnets disconnected, the short is in the trailer wiring.

All electrical troubleshooting procedures should start at the controller. Most complaints regarding brake harshness or malfunction are traceable to improperly adjusted or non-functioning controllers. See your controller manufacturer's data for proper adjustment and testing procedures. For best results, all the connection points in the brake wiring should be sealed to prevent corrosion. Loose or corroded connectors will cause an increase in resistance which reduces the voltage available for the brake magnets.

STORAGE

Storage

Storage Preparation

If your trailer is to be stored for an extended period of time or over the winter, it is important that the trailer be prepared properly.

1. Remove the emergency breakaway battery and store inside, out of the weather. Charge the battery at least every 90 days.
2. Jack up the trailer and place jack stands under the trailer frame so that the weight will be off the tires. Follow trailer manufacturer's guidelines to lift and support the unit. Never jack up or place jack stands on the axle tube or on the equalizers.



CAUTION

Do not lift or support the trailer on any part of the axle or suspension system. Never go under any trailer unless it is properly supported on jack stands which have been rated for the load. Improperly supported vehicles can fall unexpectedly and cause serious injury or death.

3. Lubricate mechanical moving parts such as the hitch, and suspension parts, that are exposed to the weather.
4. Boat trailer axles are subject to repeated immersion. Before storing, remove brake drums; clean, dry and re-lubricate moving brake components; inspect bearings - clean and re-lubricate.
5. On oil lubricated hubs, the upper part of the roller bearings are not immersed in oil and are subject to potential corrosion. For maximum bearing life, it is recommended that you revolve your wheels periodically (every 2-3 weeks) during periods of prolonged storage.

Storage

STORAGE (CONTINUED)***After Prolonged Storage
Inspection Procedure***

Before removing trailer from jack stands:

1. Remove all wheels and hubs or brake drums. Note which spindle and brake that the drum was removed from so that it can be reinstalled in the same location.
2. Inspect suspension for wear.
3. Check tightness of hanger bolt, shackle bolt, and U-bolt nuts per recommended torque values.
4. Check brake linings, brake drums and armature faces for excessive wear or scoring.
5. Check brake magnets with an ohmmeter. The magnets should check 3.2 ohms. If shorted or worn excessively, they must be replaced.
6. Lubricate all brake moving parts using a high temperature brake lubricant (LUBRIPLATE or Equivalent).

CAUTION

Do not get grease or oil on brake linings or magnet face.

7. Remove any rust from braking surface and armature surface of drums with fine emery paper or crocus cloth. Protect bearings from contamination while so doing.
8. Inspect oil or grease seals for wear or nicks. Replace if necessary.
9. Lubricate hub bearings. Refer to procedure in manual.
10. Reinstall hubs and adjust bearings per instructions in manual.
11. Mount and tighten wheels per instructions in manual.

Storage

STORAGE (CONTINUED)

Trip Preparation Checklist

There are a number of simple rules to follow in caring for your trailer axle assembly that can add to its life and in the case of some of these rules, you may be protecting your own life as well.

Using the following checklist before starting a trip with your trailer is highly recommended. Some of these items should be checked 2-3 weeks prior to a planned trip to allow sufficient time to perform maintenance.

1. Check your maintenance schedule and be sure you are up-to-date.
2. Check hitch. Is it showing wear? Is it properly lubricated?
3. Fasten safety chains and breakaway switch actuating chain securely. Make certain the breakaway battery is fully charged.
4. Inspect towing hookup for secure attachment.
5. Load your trailer so that approximately 10% of the trailers total weight is on the hitch. For light trailers this should be increased to 15%.
6. **Do Not Overload.** Stay within your gross vehicle rated capacity (consult your trailers identification plate).
7. Inflate tires according to manufacturer's specifications; inspect tires for cuts, excessive wear, etc.
8. Check wheel mounting nuts/bolts with a torque wrench. Torque in proper sequence, to the levels specified in this manual.
9. Make certain the brakes are synchronized and functioning properly.
10. Check tightness of hanger bolt, shackle bolt, and U-bolt nuts per torque values specified in manual.
11. Check operation of all lights.
12. Check that your trailer is towing in a level position and adjust hitch height if required.

Storage

TROUBLE SHOOTING

Introduction to Troubleshooting

Proper brake function is critical to the safe operation of any vehicle. A properly installed vacuum/hydraulic, electric/hydraulic, or air/hydraulic system should not require any special attention with the exception of routine maintenance as defined by the manufacturer. If problems occur, the entire tow vehicle/trailer braking system should be analyzed by a qualified mechanic. Typical problems in a hydraulic braking system are:

- Air or vacuum leaks
- Hydraulic system leaks
- Air in brake lines
- Water or other impurity in brake fluid
- Rusted or corroded master or wheel cylinders
- Actuation system malfunction

Please consult the following troubleshooting charts to determine the causes and solutions for common problems found in trailer braking systems.

CAUTION

The operating pressure required for Dexter brakes:

- **7" diameter drum brakes**
maximum operating pressure is 750 psi
- **10" diameter and larger drum brakes**
maximum operating pressure is 1,000 psi
- **Hydraulic disc brakes (all sizes)**
maximum operating pressure is 1,600 psi

TROUBLE SHOOTING (CONTINUED)

Troubleshooting

SYMPTOM	CAUSES	REMEDIES
No Brakes	Broken or Kinked Brake Line	Repair or Replace
	Severe Underadjustment	Adjust Brakes
	Malfunctioning Actuation System	Troubleshoot System
Weak Brakes	Brake Adjustment Not Correct	Manual-Adjust Brakes Automatic-Make Several Reverse Stops
	Excessively Worn Brake Linings	Replace Shoe and Lining
	Incorrect Lining	Install Correct Shoe and Lining
	Grease or Fluid Soaked Lining	Repair Grease Seal or Wheel Cylinder. Install New Shoe and Lining.
	Frozen Master Cylinder or Wheel Cylinder Pistons	Recondition or Replace All Cylinders, Brake Fluid
	Glazed Lining	Reburnish or Replace
	Excessive Drum Wear	Replace
	Trapped Air in Lines	Bleed System
Harsh Brakes	Overloaded Trailer	Correct
	Malfunctioning Actuating System	Troubleshoot System
Surging Brakes	Brake Adjustment Not Correct	Manual-Adjust Brakes Automatic-Make Several Reverse Stops
	Grease or Fluid on Linings	Replace Shoes and Linings
	Grease or Oil on Linings	Clean or Replace
	Out of Round Drums or Cracked Drums	Machine or Replace

Braking Systems - Hydraulic

TROUBLE SHOOTING (CONTINUED)

Braking Systems - Hydraulic

Troubleshooting

SYMPTOM	CAUSES	REMEDIES
Noisy Brakes	Underadjustment	Adjust
	Lack of Lubrication	Lubricate
	Broken Brake Components	Replace Components
	Incorrect Brake Components	Correct
Locking Brakes	Loose, Bent or Broken Brake Components	Replace Components
	Underadjustment	Adjust
	Out-of-Round Drums	Machine or Replace
Pulls to One Side	Incorrect Tire Pressure	Inflate Evenly on Both Sides to Req. Pressures
	Unmatched Tires on Same Axle	Match Tires on Axle
	Restricted Brake Lines or Hoses	Repair or Replace
	Malfunctioning Cylinder Assembly	Check for Stuck or Sluggish Pistons
	Defective or Damaged Shoe and Lining	Install New Shoe and Lining-Complete Axle
	One Side Out-of-Adjustment	Adjust
Dragging	Improper Fluid	Replace Rubber Parts Fill with DOT4 Fluid
	Blocked Master Cylinder	Open with Compressed Air or Replace Cylinder
	Parking Brake Cable Frozen	Free Cable and Lubricate
	Improper Lining Thickness or Location	Install New Shoes and Linings

TROUBLE SHOOTING (CONTINUED)

Introduction to Troubleshooting

Proper brake function is critical to the safe operation of any vehicle. If problems are encountered with your trailer braking system, the following guide can be used to find the causes and remedies for some of the more common problems. If you are unsure or unable to resolve the problem, please contact your nearest repair facility for professional assistance.

Troubleshooting

Most electric brake malfunctions that cannot be corrected by either brake adjustments or synchronization adjustments, can generally be traced to electrical system failure. Voltmeters and ammeters are essential tools for proper troubleshooting of electric brakes.

Mechanical causes are ordinarily obvious, i.e. bent or broken parts, worn out linings or magnets, seized lever arms or shoes, scored drums, loose parts, etc. Replace defective parts with genuine Dexter replacements.

Please consult the following troubleshooting charts to determine the causes and solutions for common problems found in trailer braking systems.



CAUTION

Best braking performance is achieved with a controller setting that is just short of wheel lock up or slide. Overly aggressive braking which results in wheel lock up and sliding, can cause a dangerous loss of control and result in personal injury or death.

TROUBLE SHOOTING (CONTINUED)

Braking Systems - Electric

Troubleshooting

SYMPTOM	CAUSES	REMEDIES
No Brakes	Open Circuits	Find & Correct
	Severe Underadjustment	Adjust Brakes
	Faulty Controller	Test & Correct
	Short Circuits	Find & Correct
Weak Brakes	Grease or Oil on Magnets or Linings	Clean or Replace
	Corroded Connections	Clean & Correct Cause of Corrosion
	Worn Linings or Magnets	Replace
	Scored or Grooved Brake Drums	Machine or Replace
	Improper Synchronization	Correct
	Underadjustment	Adjust Brakes
	Glazed Linings	Reburnish or Replace
	Overloaded Trailer	Correct
Locking Brakes	Underadjustment	Adjust
	Improper Synchronization	Correct
	Faulty Controller	Test & Correct
	Loose, Bent or Broken Brake Components	Replace Components
	Out-of-Round Brake Drums	Machine or Replace
	Insufficient Wheel Load	Adjust System Resistor and Synchronize
Intermittent Brakes	Faulty Controller	Test & Correct
	Broken Wires	Repair or Replace
	Loose Connections	Find & Repair
	Faulty Ground	Find & Repair

TROUBLE SHOOTING (CONTINUED)

Troubleshooting

Braking Systems - Electric

SYMPTOM	CAUSES	REMEDIES
Brakes Pull to One Side	Wrong Magnet Lead Wire Color	Correct
	Incorrect Adjustment	Adjust
	Grease or Oil on Linings or Magnets	Clean or Replace
	Broken Wires	Find & Repair
	Bad Connections	Find & Repair
Harsh Brakes	Underadjustment	Adjust
	Improper Synchronization	Correct
	Improper Controller	Change
	Faulty Controller	Test & Correct
Noisy Brake	Underadjustment	Adjust
	Lack of Lubrication	Lubricate
	Broken Brake Components	Replace Component
	Incorrect Brake Components	Correct
Surging Brakes	Grease or Oil on Linings or Magnet	Clean or Replace
	Out-of-Round or Cracked Brake Drums	Machine or Replace
	Faulty Controller	Test & Correct
Dragging Brakes	Overadjustment	Readjust
	Out-of-Round Brake Drums	Machine or Replace
	Incorrect Brake Components	Replace
	Loose, Bent or Broken Brake Components	Replace
	Faulty Breakaway Switch	Repair or Replace
	Loose Wheel Bearing Adjustment	Adjust
	Bent Spindle	Replace Axle



11 ANSI REPRINT

The following sections are reprinted from the ANSI code in effect at the time of manufacture and govern the safe use of the Haulotte Group.

It is the responsibility of all owners and operators of this machine to read, understand and obey the recommendations set forth by the ANSI code.

Permission to reprint this material has been granted by the Scaffold Industry Association.

7. Responsibilities of Dealers and Installers

- 7.1 General Responsibilities.** Each dealer or installer as applicable shall comply with the requirements of this section.
- 7.2 Vehicle Specifications.** Each dealer or installer, or both, who sells an aerial device shall inform the owner or user, or both, of the manufacturer's minimum vehicle specifications.
- 7.3 Vehicle Weight Distribution.** The installer shall be responsible for the weight distribution of the completed mobile unit in accordance with the requirements of the aerial device and the applicable regulations. Allowance shall be made for the weight of readily removable tools and material specified by the user.
- 7.4 Manuals.** Upon delivery of the equipment to the owner or user, the dealer or installer shall provide the manuals as required by Paragraph 6.4 of this standard and manuals for auxiliary equipment added by the installer.
- 7.5 Installations.** The installer shall comply with Sections 5 and 6 of this standard relating to proper installation and shall follow the instructions of the manufacturer. In the event the original manufacturer no longer exists, an equivalent entity may provide these instructions. The installer shall maintain access to the lower controls as described in section 4.3.3. The installer of an aerial device shall, before the mobile unit is placed in operation, perform stability tests in accordance with the requirements of 4.5.1 and 4.5.2, the operational and visual tests in accordance with the requirements of 6.6.1 and 6.6.2, and the appropriate electrical tests required in 5.4 of this standard. For insulating aerial devices, the installer shall assure conformance to the Qualification test requirements of 5.3.2 by either obtaining a certification of the test and performing a periodic test after installation, or by performing the Qualification test. The installer shall, when installing an aerial device on a chassis which is a highway vehicle, comply with all requirements of the applicable Federal Motor Vehicle Safety Standards in effect at the time of installation. Certification as a manufacturer (alteration, intermediate or final) of a motor vehicle under the Federal Motor Vehicle Safety Standards is required. The travel height of the mobile unit shall be posted in a location that is readily visible to the vehicle operator.
- 7.6 Quality Assurance.** The installer shall have a documented quality assurance program which will ensure compliance with this standard.
- 7.7 Weldings.** All welds made by the installer, whose failure could result in motion of the platform(s) shall meet the Structural Welding Code AWS D1.1-2006 or AWS D1.2-2003. The installer shall establish applicable welding quality assurance procedures for all weldments.
- 7.8 Training.** The dealer or installer shall offer training or training materials that aid owners, users, operators, lessors and lessees in the operation, inspection, testing and maintenance of the aerial device. This training shall be offered initially and subsequently on request.

7.8.1 Dealer or Installer as User. Whenever a dealer or installer directs personnel to operate an aerial device (inspecting, sales demonstrations, or any form of use), the dealer or installer shall assume the responsibilities of users as specified in Section 9 of this standard. All personnel authorized to operate the aerial device shall have been trained in a program that meets the requirements of this standard.

7.9 Maintenance Training. Dealer maintenance personnel shall be trained in inspection, testing and maintenance of the aerial device in accordance with the manufacturer's recommendations.

8. Responsibilities of Owners

- 8.1 General Responsibilities.** Each owner shall comply with the requirements of this section. The following responsibilities pertain to the owner's inspection, testing, maintenance, modification, training, and transfer of ownership. These activities shall be performed by qualified person(s).
- 8.2 Inspection and Testing Classifications.**
- 8.2.1 Initial Inspection and Test.** Prior to initial use, all new or modified mobile units shall be inspected and tested to ensure compliance with the provisions of this standard. Certification by the manufacturer, dealer, final installer or an equivalent entity(s) meets this requirement.
- 8.2.2 Regular Inspection and Tests.** The inspection procedure for mobile units is divided into two classifications based upon the intervals at which inspections and tests shall be performed. Intervals shall be set by the owner in accordance with the manufacturer's recommendations. Such intervals are dependent upon component function and exposure to wear, deterioration and other agents which adversely affect component life. Two classifications are designated:
- (1) Frequent Inspection and Test: Daily to monthly intervals.
 - (2) Periodic Inspection and Test: One to twelve month intervals.
- 8.2.3 Frequent Inspection and Test.** Items determined by the owner in accordance with the manufacturer's recommendations for each specific aerial device shall be inspected for defects. The following inspections and tests shall be performed by the operator immediately prior to first use at the beginning of each shift:
- (1) Conduct walk around visual inspection looking for damaged components, cracks or corrosion, excessive wear and any loose, deformed or missing bolts, pins, fasteners, locking devices and covers.
 - (2) Check all controls and associated mechanisms for proper operation to include, but not limited to, the following:
 - a) Proper operation of interlocks.
 - b) Controls return to neutral when released and not sticking.
 - c) Control functions and operation clearly marked.

- (3) Check visual and audible safety devices for proper operation.
- (4) Visually inspect fiberglass and insulating components for visible damage and contamination.
- (5) Check for missing or illegible operational and instructional markings.
- (6) Check hydraulic and pneumatic systems for observable deterioration and excessive leakage.
- (7) Check electrical systems related to the aerial device for malfunctions, signs of excessive deterioration, dirt and moisture accumulation.
- (8) Perform functional test to include, but not limited to, the following:
 - (a) Set-up the aerial device for operation, including outriggers.
 - (b) Cycle the aerial device functions through the complete range of motion from the lower controls, except where operation through the complete range of motion would create a hazard.
 - (c) Check functionality of emergency controls.

Any suspected items shall be carefully examined or tested and a determination made by a qualified person as to whether they constitute a safety hazard. All unsafe items shall be replaced or repaired before use.

8.2.4 Periodic Inspection or Test. An inspection of the mobile unit shall be performed at the intervals defined in 8.2.2 depending upon its activity, severity of service, and environment, or as specifically indicated below. (These inspections shall include the requirements of 8.2.3):

- (1) Structural members for deformation, cracks or corrosion.
- (2) Parts, such as pins, bearings, shafts, gears, rollers, locking devices, chains, chain sprockets, wire and synthetic ropes, and sheaves for wear, cracks or distortion.
- (3) Hydraulic and pneumatic relief valve settings.
- (4) Hydraulic system for proper oil level.
- (5) Hydraulic and pneumatic fittings, hoses, and tubing for evidence of leakage, abnormal deformation or excessive abrasion.
- (6) Compressors, pumps, motors, and generators for loose fasteners, leaks, unusual noises or vibrations, loss of operating speed and excessive heating.
- (7) Hydraulic and pneumatic valves for malfunction and visible cracks in the external valve housing, leaks, and sticking spools.
- (8) Visually inspect any vacuum prevention systems and verify function of such systems.
- (9) Hydraulic and pneumatic cylinders and holding valves for malfunction and visible damage.
- (10) Hydraulic and pneumatic filters for cleanliness and the presence of foreign material in the system indicating other component deterioration.
- (11) Electrical systems and components for deterioration or wear including those not readily visible on a frequent inspection.
- (12) Performance test of all boom movements.
- (13) Condition and tightness of bolts and other fasteners in accordance with the manufacturer's recommendation.
- (14) Welds, as specified by the manufacturer.
- (15) Legible and proper identification, operational, and instructional markings.
- (16) If the aerial device is rated as an insulating device, the electrical insulating components and system(s) shall be thoroughly inspected for lack of cleanliness and other conditions that compromise insulation. Then these components and system(s) shall be tested for compliance with the rating of the aerial device in accordance with one of the applicable

methods and procedures as outlined in section 5.4.3 of this standard:

- (a) If the aerial device is used for ac bare-hand work, the 'in the field' tests outlined in 5.4.3.1 (10) (c) may be relied upon when performed frequently, however the unit shall undergo an ac voltage test at least every three years in accordance with Table 2 criteria;
 - (b) If the aerial device is used for dc bare-hand work, the 'in the field' tests outlined in 5.4.3.1 (10) (c) may be relied upon when performed frequently, however the unit shall undergo an appropriate dc over voltage test at least every three years;
 - (c) After repair or replacement of any component that crosses the insulating system(s), or the repair or replacement of an insulating component(s) (e.g., hoses, leveling rods, boom coating, etc.), the unit shall be dielectrically tested in accordance with section 5.4.3;
 - (d) An insulating replacement boom shall be tested to ensure conformance to 5.3.3 by the supplier;
 - (e) Bare-hand work units shall be tested for the applicable unit rating in accordance with Table I (or appropriate dc test for units used on direct current lines, see Appendix B) after any major repair to the insulating boom or any insulating boom replacement. Major repair to the insulating boom shall include resurfacing or repainting of the exterior or interior boom surfaces. The removal and subsequent reinstallation of a gradient control device is not considered a 'major repair' provided proper reinstallation of the gradient control device is performed by a qualified person in accordance with the manufacturer's instructions.
- (17) If the aerial device has upper controls equipped with high electrical resistance components and the manufacturer so indicates, they shall be maintained as high electrical resistance components and should be electrically tested per 5.4.3.6. Any suspected items shall be carefully examined or tested and a determination made by a qualified person as to whether they constitute a safety hazard. All unsafe items shall be replaced or repaired before use.

8.2.5 Post Event Inspection or Test. After any reported event during which structural members of an aerial device or mobile unit are suspected of being subjected to loading or stresses in excess of design stress such as after an accident involving overturning of the mobile unit or application of unintended external mechanical or electrical forces to the aerial device, the aerial device shall be removed from service and subjected to the applicable periodic inspection requirements in 8.2.4. In addition to the periodic inspection, supplemental non-destructive examination procedures or other tests to assist in detecting possible structural damage to the aerial device may be required. All damaged items shall be replaced or repaired before the unit is returned to service. Return to service shall be approved by a qualified person.

8.3 Inspection and Test Records.

8.3.1 Frequent. Items to be inspected shall be designated to the operator or other authorized person making frequent inspections. Records of frequent inspections need not be made. However, where a safety hazard is found, it shall be reported in writing to a person responsible for the corrective action and that report and a record of the

correction shall be maintained for five years, or as required by applicable regulations.

8.3.2 Periodic. Written, or appropriately archived electronic, dated and signed reports and records shall be made of periodic inspections and tests and retained for a period of five years or as required by applicable regulations.

8.4 Maintenance. Maintenance and frequency of maintenance shall be determined by the owner in accordance with the manufacturer's recommendations.

8.4.1 Maintenance Training. The owner shall train their maintenance personnel in inspection and maintenance of the aerial device in accordance with the manufacturer's recommendations and Section 8 of this standard.

8.4.2 Weldings. Welding repairs of components or welds, designated as critical in the manufacturer's manual shall be made in accordance with the manufacturer's recommendations and shall meet the Structural Welding Code AWS D1.1-2006 or AWS D1.2-2003. Should the original manufacturer no longer exist, an equivalent entity may determine the required procedure.

8.5 Modifications. No modifications or additions which affect the stability, mechanical, hydraulic, or electrical integrity or the safe operation of the aerial device shall be made without the written approval of the manufacturer. If such modifications or changes are made, the capacity, operation, and maintenance instruction markings shall be changed accordingly. In no case shall the safety factors be reduced below those specified in this standard or below the manufacturer's design safety factors, whichever are greater. Should the original manufacturer no longer exist, an equivalent entity may approve required modification.

8.5.1 Alterations. Altering or disabling the function of safety devices, guards, or interlocks, if so equipped, is prohibited.

8.6 Weight Distribution. Changes in loading or additions made to the mobile unit after the final acceptance that affect weight distribution shall meet applicable regulations by governmental agencies. In no case shall axle loads of the fully loaded vehicle exceed the Gross Axle Weight Ratings (GAWR) assigned by the manufacturer. Note: Any change in weight distribution may adversely affect stability.

8.7 Transfer of Ownership. When a change in ownership of an aerial device occurs, it shall be the responsibility of the seller to provide the manufacturer's manual(s) for that aerial device to the purchaser. It is the responsibility of the purchaser to notify the manufacturer of the unit model and serial number and the name and address of the new owner within 60 days. If the owner uses other entities as agents (e.g., Brokers) for the sale or the arrangement of a sale of an aerial device(s) their responsibilities under this section continue.

8.8 Markings. The markings on the aerial device shall not be removed, defaced, or altered. All missing or illegible markings shall be promptly replaced.

8.9 Parts. When parts or components are replaced they shall be identical in specification and function to the original aerial device parts or components or shall provide an equal or greater factor of safety.

8.10 Safety Bulletins. Owners shall comply with safety related bulletins as received from the manufacturer, dealer or installer.

8.11 Manuals. The owner shall insure that the operating manual(s) is stored on the mobile unit.

8.12 Training, Retraining, and Familiarization of Operators.

8.12.1 General Training. Only personnel who have received general instructions regarding the inspection, application and operation of aerial devices, including recognition and avoidance of hazards associated with their operation, shall operate an aerial device. Such items covered shall include, but not necessarily be limited to, the following issues and requirements:

- (1) The purpose and use of manuals.
- (2) That operating manuals are an integral part of the aerial device and must be properly stored on the vehicle when not in use.
- (3) A pre-start inspection.
- (4) Responsibilities associated with problems or malfunctions affecting the operation of the aerial device.
- (5) Factors affecting stability.
- (6) The purpose of placards and decals.
- (7) Workplace inspection.
- (8) Applicable safety rules and regulations, such as Part 4, ANSI C2-2007, National Electrical Safety Code (applies to utility workers as defined in ANSI C2). The above standard is an example; other industries using aerial devices have safety rules pertinent to that industry.
- (9) Authorization to operate.
- (10) Operator warnings and instructions.
- (11) Actual operation of the aerial device. Under the direction of a qualified person, the trainee shall operate the aerial device for a sufficient period of time to demonstrate proficiency in the actual operation of the aerial device.
- (12) Proper use of personal fall protection equipment. Fall protection systems criteria and practices are covered in 29 CFR 1926.502.

8.12.2 Retraining. The operator shall be retrained, when so directed by the user, based on the user's observation and evaluation of the operator.

8.12.3 Familiarization. When an operator is directed to operate an aerial device they are not familiar with, the operator, prior to operating, shall be instructed regarding the following items:

- (1) The location of the manuals.
- (2) The purpose and function of all controls.
- (3) Safety devices and operating characteristics specific to the aerial device.
- (4) Under the direction of a qualified person, the trainee shall operate the aerial device for a sufficient period of time to demonstrate proficiency in the actual operation of the aerial device.

8.13 Owner as a Lessor. When owners function as lessors, they shall have the same responsibilities as specified under Section 11 of this standard.

9. Responsibilities of Users.

9.1 General Responsibilities. Each User shall comply with the requirements of this section.

9.2 Personnel. Only trained and authorized personnel shall be permitted to operate the aerial device.

9.3 Training, Retraining, and Familiarization of Operators.

9.3.1 General Training. Only personnel who have received general instructions regarding the inspection, application and operation of aerial devices, including recognition and avoidance of hazards associated with their operation, shall operate an aerial device. Such items covered shall include, but not necessarily be limited to, the following issues and requirements:

- (1) The purpose and use of manuals.

- (2) That operating manuals are an integral part of the aerial device and must be properly stored on the vehicle when not in use.
- (3) A pre-start inspection.
- (4) Responsibilities associated with problems or malfunctions affecting the operation of the aerial device.
- (5) Factors affecting stability.
- (6) The purpose of placards and decals.
- (7) Workplace inspection.
- (8) Applicable safety rules and regulations, such as Part 4, ANSI C2-2007, National Electrical Safety Code. (applies to utility workers as defined in ANSI C2). The above standard is an example; other industries using aerial devices have safety rules pertinent to that industry.
- (9) Authorization to operate.
- (10) Operator warnings and instructions.
- (11) Actual operation of the aerial device. Under the direction of a qualified person, the trainee shall operate the aerial device for a sufficient period of time to demonstrate proficiency in the actual operation of the aerial device.
- (12) Proper use of personal fall protection equipment. Fall protection systems criteria and practices are covered in 29 CFR 1926.502.

9.3.2 Retraining. The operator shall be retrained, when so directed by the user, based on the user's observation and evaluation of the operator.

9.3.3 Familiarization. When operators are directed to operate an aerial device with which they are not familiar, they shall receive prior instruction regarding the following items:

- (1) The location of the manuals.
- (2) The purpose and function of all controls.
- (3) Safety devices and operating characteristics specific to the aerial device.
- (4) Under the direction of a qualified person, the trainee shall operate the aerial device for a sufficient period of time to demonstrate proficiency in the actual operation of the aerial device.

9.3.4 Proof of Training. Users providing training should provide successful trainees a means to evidence their training and should provide such proof if requested by the trainee. The document evidencing training shall include the following information:

- (1) Name of trainee
- (2) Name of entity providing training or retraining
- (3) Name of trainer(s)
- (4) Clear identification of the make(s) and model(s) of the mobile unit(s) on which the operator has been trained.

9.4 Application. The employer and authorized operator(s) shall insure that the aerial device is used only for intended applications as defined in the operating manual and that all recognized safety practices are observed.

Note: The User is directed to Appendix C for guidance as to appropriate applications.

9.5 Electrical Hazard. All applicable safety related work practices intended to protect from electrical hazards shall be defined and explained to the operator by a qualified person. The operator shall maintain the appropriate Minimum Approach Distance (MAD) from energized conductors and apparatus, commensurate with the operator's qualifications. See Appendix F for the information on the Minimum Approach Distances and other precautions.

9.6 Bare-Hand Work. For bare-hand work, a Category A aerial device shall be used.

9.7 Lower Controls. The lower controls of aerial devices shall not be used for continuous operation with personnel in the platform.

9.8 Manufacturer's Safety Bulletins. The user shall comply with the applicable safety-related bulletins as received from the manufacturer, installer, dealer or owner.

10. Responsibilities of Operators

10.1 General Responsibilities. Each operator shall comply with the requirements of this section.

10.2 Personnel. Only trained and authorized personnel shall be permitted to operate the aerial device.

10.3 Operation. During operation of the aerial device all platform occupants shall use appropriate fall protection connected to the aerial device anchorage(s).

10.4 Work Platform. The operator shall not use railings, planks, ladders or any other device in or on the work platform for achieving additional working height or reach.

10.5 Brakes. The vehicle parking brake(s) shall be set at all times that the boom is elevated except when the aerial device is being used in accordance with 10.11.

10.6 Loading. Any loading which includes a horizontal load shall be avoided unless the mobile unit is designed for that application.

10.7 Alterations. Altering or disabling the function of safety devices, guards or interlocks, if so equipped, is prohibited.

10.8 Observations. Observations during operation for any defects shall be conducted on an ongoing basis.

10.8.1 Pre-start Inspection. Items determined by the owner in accordance with the manufacturer's recommendations for each specific aerial device shall be inspected for defects prior to each day's operation. The following tests and inspections shall be performed by the operator once daily, prior to first use:

- (1) Conduct walk around visual inspection, looking for damaged components, cracks or corrosion, excessive wear and any loose, deformed or missing bolts, pins, fasteners, locking devices and covers.
- (2) Check all controls and associated mechanisms for proper operation to include, but not limited to, the following:
 - (a) Proper operation of interlocks.
 - (b) Controls return to neutral when released and not sticking.
 - (c) Control functions and operation clearly marked.
- (3) Check visual and audible safety devices for proper operation.
- (4) Visually inspect fiberglass and insulating components for visible damage and contamination.
- (5) Check for missing or illegible operational and instructional markings.
- (6) Check hydraulic and pneumatic systems for observable deterioration and excessive leakage.
- (7) Check electrical systems related to the aerial device for malfunction, signs of excessive deterioration, dirt, and moisture accumulation.
- (8) Perform functional test to include, but not limited, to the following:
 - (a) Set-up aerial device for operation, including outriggers.
 - (b) Cycle each aerial device boom function through its complete range of motion from the lower controls, except where operation through the complete range of motion would create a hazard.
 - (c) Check functionality of emergency controls.

Any suspected items shall be carefully examined or tested and a determination made by a qualified person as to whether they constitute a safety hazard. All unsafe items shall be replaced or repaired before use.

- 10.9 Worksite.** Before the aerial device is used the worksite shall be surveyed for hazards such as:
- (1) Insufficient supporting surfaces such as soft ground or tamped earth fills.
 - (2) Ditches.
 - (3) Excessive slopes, drop-offs, curbs, and floor obstructions.
 - (4) Debris.
 - (5) Overhead obstructions and electrical conductors.
 - (6) Weather conditions.
 - (7) Presence of unauthorized persons.
 - (8) Road or worksite traffic.
 - (9) Subsurface chambers such as underground utility components or septic systems.
- 10.10 Precautions.** Before and during each use the operator shall:
- (1) Check for overhead obstructions and electrical conductors.
 - (2) Insure that the load on the platform and/or load lifting device is in accordance with the manufacturer's rated capacity.
 - (3) Insure that outriggers and stabilizers are used if the manufacturer's instructions require their use.
 - (4) Insure that guardrails are properly installed, and the gates are closed.
 - (5) Use outrigger pads when necessary to provide firm footing.
- 10.11 Mobile Operation.** Before engaging in mobile operation the operator shall determine that the aerial device is specifically designed for mobile operation.
- 10.11.1 Driver Precautions.** Before and during driving, the driver shall:
- (1) Avoid traveling on any surface that adversely affects vehicle stability.
 - (2) Maintain a safe distance from obstacles and overhead lines.
 - (3) Maintain communications between driver and operator.
 - (4) Under all travel conditions, the driver shall limit travel speed in accordance with conditions of the ground surface, congestion and slope.
- 10.12 Training, Retraining, and Familiarization of Operators.**
- 10.12.1 General Training.** Only personnel who have received general instructions regarding the inspection, application and operation of aerial devices, including recognition and avoidance of hazards associated with their operation, shall operate an aerial device. Such items covered shall include, but not necessarily be limited to, the following issues and requirements:
- (1) The purpose and use of manuals.
 - (2) That operating manuals are an integral part of the aerial device and must be properly stored on the vehicle when not in use.
 - (3) A pre-start inspection.
 - (4) Responsibilities associated with problems or malfunctions affecting the operation of the aerial device.
 - (5) Factors affecting stability.
 - (6) The purpose of placards and decals.
 - (7) Workplace inspection.
 - (8) Applicable safety rules and regulations, such as Part 4, ANSI C2-2007, National Electrical Safety Code (applies to utility workers as defined in ANSI C2). The above standard is an example;

other industries using aerial devices have safety rules pertinent to that industry.

- (9) Authorization to operate.
- (10) Operator warnings and instructions.
- (11) Proper use of personal fall protection equipment. Fall protection systems criteria and practices are covered in 29 CFR 1926.502.

10.12.2 Retraining. The operator shall be retrained, when so directed by the user, based on the user's observation and evaluation of the operator.

10.12.3 Familiarization. When operators are directed to operate an aerial device with which they are not familiar, they shall be instructed, prior to operating the aerial device, regarding the following items:

- (1) The location of the manuals.
- (2) The purpose and function of all controls.
- (3) Safety devices and operating characteristics specific to the aerial device.
- (4) Under the direction of a qualified person, the trainee shall operate the aerial device for a sufficient period of time to demonstrate proficiency in the actual operation of the aerial device.

10.13 Electrical Hazard. All applicable safety related work practices intended to protect personnel from electrical hazards shall be defined and explained to the operator by a qualified person. The operator shall maintain the appropriate Minimum Approach Distance (MAD) from energized conductors and apparatus, commensurate with the operator's qualifications. See Appendix F for information on the Minimum Approach Distance and other precautions.

11. Responsibilities of Lessors or Lessees

11.1 General Responsibilities. Each lessor or lessee shall comply with the requirements of the applicable section or sections below.

11.1.1 Lessor or Lessee as Dealer or Installer. When a lessor or lessee uses the aerial device as a dealer or installer they shall have the same responsibilities as specified under Section 7 of this standard.

11.1.2 Lessor or Lessee as Owner. When a lessor or lessee uses the aerial device as an owner they shall have the same responsibilities as specified under Section 8 of this standard.

11.1.3 Lessor or Lessee as User. When a lessor or lessee uses the aerial device as a user they shall have the same responsibilities as specified under Section 9 of this standard.

11.1.4 Lessor or Lessee as Operator. When a lessor or lessee uses the aerial device as an operator they shall have the same responsibilities as specified under Section 10 of this standard.

11.2 Ownership Responsibilities. The lessor shall carry out the responsibilities of ownership specified in this standard which are not assigned to the lessee as the user.

11.3 Obligations. Upon delivery each lessor of an aerial device shall provide the operators manual and the ANSI/SIA A92.2-2009 Manual of Responsibilities for dealers, owners, users, operators, lessors, lessees and brokers of Vehicle Mounted Elevating and Rotating Aerial Devices. These manuals shall be stored on the mobile unit.

11.3.1 Inspection and Test. Prior to delivery, the lessor of an aerial device shall perform a frequent inspection as specified in Section 8.2.3 of this standard.

- 11.3.2 Responsibilities.** Upon delivery, each lessor of an aerial device shall inform the lessee of their responsibilities in accordance with Section 8 as to inspection, testing and maintenance requirements; Section 9 as to user's responsibilities; and Section 10 as to operator's responsibilities.
- 11.4 Training.** The lessor shall offer training or training materials that aid the lessee in the operation, inspection, testing and maintenance of the aerial device. This training shall be offered initially and subsequently on request.
- 11.4.1 General training.** Only personnel who have received general instructions regarding the inspection, application and operation of aerial devices, including recognition and avoidance of hazards associated with their operation, shall operate an aerial device. Such items covered shall include, but not necessarily be limited to, the following issues and requirements:
- (1) The purpose and use of manuals.
 - (2) That operating manuals are an integral part of the aerial device and must be properly stored on the vehicle when not in use.
 - (3) A pre-start inspection.
 - (4) Responsibilities associated with problems or malfunctions affecting the operation of the aerial device.
 - (5) Factors affecting stability.
 - (6) The purpose of placards and decals.
 - (7) Workplace inspection.
 - (8) Applicable safety rules and regulations, such as Part 4, ANSI C2-2007, National Electrical Safety Code (applies to utility workers as defined in ANSI C2). The above standard is an example; other industries using aerial devices have safety rules pertinent to that industry.
 - (9) Authorization to operate.
 - (10) Operator warnings and instructions.
 - (11) Proper use of personal fall protection equipment. Fall protection systems criteria and practices are covered in 29 CFR 1926.502.
 - (12) Electrical hazards and Minimum Approach Distance to energized conductors and apparatus. See Appendix F.

- 11.4.2 Familiarization.** When operators are directed to operate an aerial device with which they are not familiar, they shall be instructed, prior to operating the aerial device, regarding the following items:
- (1) The location of the manuals.
 - (2) The purpose and function of all controls.
 - (3) Safety devices and operating characteristics specific to the aerial device.
 - (4) Under the direction of a qualified person, the trainee shall operate the aerial device for a sufficient period of time to demonstrate proficiency in the actual operation of the aerial device.
- 11.5 Communications.** In the event the manufacturer or installer provides the lessor manuals, bulletins, or other materials for the information of the user of an aerial device, the lessor shall pass them on to the user without delay.
- 11.6 Use of Brokers.** If Brokers are employed in leasing, the responsibility of lessors and lessees as specified in this Section continue even though a Broker may be involved in the transaction.
- 12. Responsibilities of Brokers**
- 12.1 Broker Involved In a Sale.** A broker involved in a sale shall:
- (1) Assure that the entity actually transferring ownership knows the proper location and identification of proper personnel of the purchasing entity.
 - (2) Confirm that operations and maintenance manuals are provided to the new owner.
 - (3) Confirm that all parties are aware of their responsibilities under Section 8.7 of this standard.
- 12.2 Broker Involved In a Lease.** A broker involved in a lease shall:
- (1) Assure that the entity actually transferring possession knows the proper location and identification of the proper personnel of the lessee or user of the aerial device.
 - (2) Confirm that the operators' manual, maintenance manual, and a Manual of Responsibilities are provided to the lessee.
 - (3) Confirm that all parties are aware of their responsibilities under Section 11.4 of this standard.

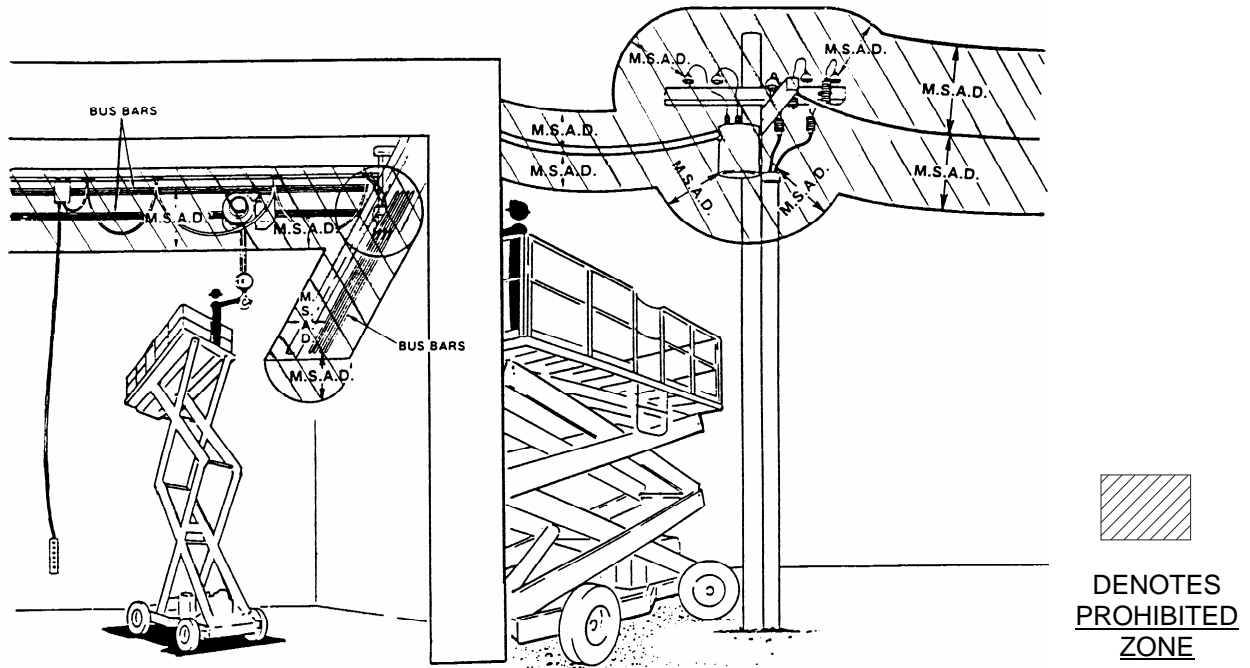

Figure 11-1. Minimum Safe Approach Distance

 **DANGER**

DO NOT allow aerial work platform, personnel, or conductive materials inside prohibited zone. Maintain M.S.A.D from all energized lines and parts as well as those shown. Assume all electrical parts and wires are energized unless known otherwise. Failure to avoid energized power sources will result in death or serious injury.

 **CAUTION**

Diagrams shown are only for purposes of illustration M.S.A.D. work positions, not all work positions.

TABLE 11-1. MINIMUM SAFE APPROACH DISTANCES		
Voltage Range (Phase to Phase)	Minimum Safe Approach Distance	
	(Feet)	(Meters)
0 to 300V	Avoid Contact	
Over 300V to 50KV	10	3.05
Over 50KV to 200KV	15	4.60
Over 200KV to 350KV	20	6.10
Over 350KV to 500KV	25	7.62
Over 500KV to 750KV	35	10.67
Over 750KV to 1000KV	45	13.72

INSPECTION FORM FOR HAULOTTE GROUP AERIAL WORK PLATFORMS

Machine Model No.		Serial No.	
Date of Manufacture:		Inspection Performed by:	
		Inspection Location:	

Inspection and Maintenance of the above listed machine shall be performed only by fully trained, authorized and, where applicable, certified personnel. All service checks shall be performed in accordance with manufacturer's recommendations (see the appropriate Parts and Service Manual) and ANSI / SIA A92 Standard. Copy this form as needed. Direct any questions to the Haulotte Group Customer Service Department: 1-888-440-9240 or visit Haulotte Group online at www.haulotte-usa.com.

Inspector: Initial in the space provided beside each service check as it is completed.

Sign and date form after Inspection.

Owner: Keep this form for your records.

Frequency Key:

D=Daily (or before each use); W = Weekly; M = Monthly; SA = Semi-Annually; A = Annually

Service Check Description	Frequency	Initials
Verify that all decals are correctly applied and in plain view.	D	
Verify that all controls and indicators at ground and platform control stations operate properly.	D	
Verify operation of running and brake lights.	D	
Verify proper tire inflation.	D	
Inspect tires for damage or loose or missing lug nuts.	D	
Inspect structural components for obvious damage or debris.	D	
Inspect machine for loose, damaged or missing fasteners, including pins and bolts.	D	
Verify that boom down limit switches operate correctly.	D	
Verify that outrigger safety interlocks operate correctly.	D	
Inspect hydraulic system and fluid levels.	D	
Check battery electrolyte level.	W	
Inspect electrical wiring	W	
Inspect transport hitch for damage	W	
Inspect boom for missing, loose or damaged hardware.	W	
Inspect all hydraulic system components including power unit, hoses and cylinders for damage, leaks, loss of pressure or speed, and unusual noise or vibration.	W	
Check engine oil. Applicable for machines with engines	W	
Clean all battery terminals.	M	
Check battery connections.	M	
Verify proper operation of manual lowering valves and hand pump.	M	
Lubricate all compartment hinges and latches, slew ring and mating gear using NLGI Grade 2 multi-purpose grease.	M	
Check wheel nut torque.	M	
Check coolant level. Applicable to 55XA aerial lift platforms only.	M	
Inspect the Air Filter. Applicable for aerial lift platforms with engines	M	
Check belt tension (engine – pump – generator). Applicable to X-Booms only.	SA	
Verify engine rpm. Applicable for machines with engines	SA	
Replace hydraulic oil and hydraulic filter.	A	
Inspect pivot pins and cylinders, including rod ends for wear or damage.	A	
Visually inspect all welds for wear, damage or corrosion.	A	
Inspect outriggers for wear or damage.	A	
Verify proper level sensor operation	A	
Inspect and adjust axle and parking brake.	A	
Load test all boom functions with a 500lb (227kg) load (440lb/200kg load if machine is equipped with jib / platform rotate).	A	
Check slew ring for wear or damage.	A	

** Refer to Engine Operator's Manual for recommended Engine Maintenance

Inspector Signature _____ **Date** ___ / ___ / _____

